

#12564

- Project instructions included
- Fits hoop sizes 5" x 7" and larger



1
DESIGN

Freestanding Pagoda

THREAD LIST



Isacord Thread Colors

- 0015 White
- 0020 Black
- 1730 Persimmon
- 1800 Wildfire
- 7009 (S1) Platinum
- 7014 (S15) Aztec Gold

DESIGNS

Note: Some designs in this collection may have been created using unique special stitches and/or techniques. To preserve design integrity when rescaling or rotating designs in your software, always rescale or rotate designs using the handles directly on-screen.

*Fabric Required

12564-01 Pagoda Front Wall FSA

Size Inches: Size mm: Stitch Count:
3.63 X 2.74 in. 92.20 X 69.60 mm 17718 St.



- 1. Placement Stitch 0015
- 2. Cut Line & Tackdown 0015
- 3. Flowers 0015
- 4. Door 0015
- 5. Swirls 1730
- 6. Light Red Door Trim 1730
- 7. Black Detail 0020
- 8. Cover Stitch & Lace 1800
- 9. Gold Detail 7014

Note: Some designs in this collection may have been created using unique special stitches and/or techniques. To preserve design integrity when rescaling or rotating designs in your software, always rescale or rotate designs using the handles directly on-screen.

*Fabric Required

12564-02 Pagoda Left Wall FSA

Size Inches: Size mm: Stitch Count:
3.63 X 2.74 in. 92.20 X 69.60 mm 14581 St.



<input type="checkbox"/>	1. Placement Stitch	0015
<input type="checkbox"/>	2. Cut Line & Tackdown.....	0015
<input type="checkbox"/>	3. Flowers.....	0015
<input type="checkbox"/>	4. Swirls.....	1730
<input type="checkbox"/>	5. Black Detail	0020
<input type="checkbox"/>	6. Cover Stitch & Lace.....	1800
<input type="checkbox"/>	7. Gold Detail.....	7014

*Fabric Required

12564-03 Pagoda Back Wall FSA

Size Inches: Size mm: Stitch Count:
3.63 X 2.74 in. 92.20 X 69.60 mm 14733 St.



<input type="checkbox"/>	1. Placement Stitch	0015
<input type="checkbox"/>	2. Cut Line & Tackdown.....	0015
<input type="checkbox"/>	3. Flowers.....	0015
<input type="checkbox"/>	4. Swirls.....	1730
<input type="checkbox"/>	5. Black Detail	0020
<input type="checkbox"/>	6. Cover Stitch & Lace.....	1800
<input type="checkbox"/>	7. Gold Detail.....	7014

Note: Some designs in this collection may have been created using unique special stitches and/or techniques. To preserve design integrity when rescaling or rotating designs in your software, always rescale or rotate designs using the handles directly on-screen.

*Fabric Required

12564-04 Pagoda Right Wall FSA

Size Inches: Size mm: Stitch Count:
3.63 X 2.74 in. 92.20 X 69.60 mm 14415 St.



<input type="checkbox"/>	1. Placement Stitch	0015
<input type="checkbox"/>	2. Cut Line & Tackdown.....	0015
<input type="checkbox"/>	3. Flowers.....	0015
<input type="checkbox"/>	4. Swirls.....	1730
<input type="checkbox"/>	5. Black Detail	0020
<input type="checkbox"/>	6. Cover Stitch & Lace.....	1800
<input type="checkbox"/>	7. Gold Detail.....	7014

*Fabric Required

12564-05 Pagoda Foundation FSA

Size Inches: Size mm: Stitch Count:
3.71 X 3.71 in. 94.23 X 94.23 mm 7380 St.

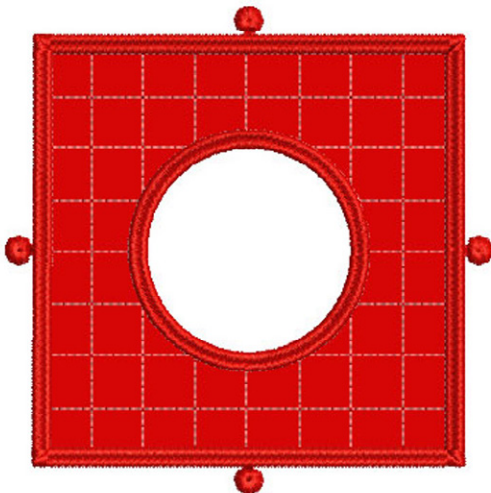

<input type="checkbox"/>	1. Placement Stitch	1800
<input type="checkbox"/>	2. Cut Line & Tackdown.....	1800
<input type="checkbox"/>	3. Cover Stitch.....	1800

Note: Some designs in this collection may have been created using unique special stitches and/or techniques. To preserve design integrity when rescaling or rotating designs in your software, always rescale or rotate designs using the handles directly on-screen.

*Fabric Required

12564-06 Pagoda Roof & Wall 1 FSA

Size Inches: Size mm: Stitch Count:
2.85 X 5.45 in. 72.39 X 138.43 mm 21225 St.

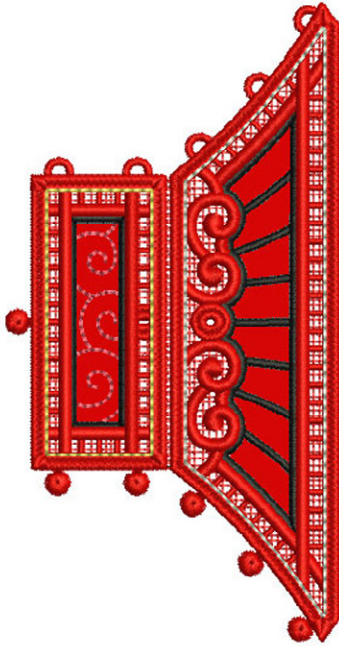

- 1. Placement Stitch 1730
- 2. Cut Line & Tackdown..... 1730
- 3. Swirls..... 1730
- 4. Black Detail 0020
- 5. Cover Stitch & Lace..... 1800
- 6. Silver Detail 7009
- 7. Gold Detail..... 7014

12564-07 Pagoda Ceiling 1 FSL

Size Inches: Size mm: Stitch Count:
2.95 X 2.95 in. 74.93 X 74.93 mm 10279 St.

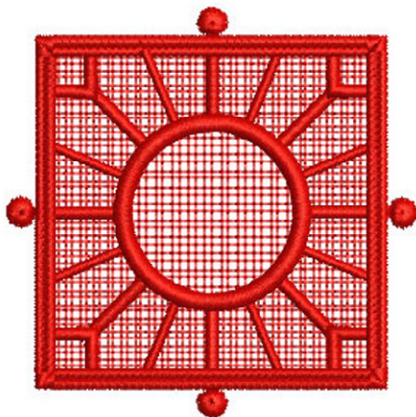

- 1. Single Color Design..... 1800

Note: Some designs in this collection may have been created using unique special stitches and/or techniques. To preserve design integrity when rescaling or rotating designs in your software, always rescale or rotate designs using the handles directly on-screen.

*Fabric Required

12564-08 Pagoda Roof & Wall 2 FSA

Size Inches: Size mm: Stitch Count:
4.20 X 3.56 in. 106.68 X 90.42 mm 19447 St.



<input type="checkbox"/>	1. Placement Stitch	0015
<input type="checkbox"/>	2. Cut Line & Tackdown.....	0015
<input type="checkbox"/>	3. Window.....	0015
<input type="checkbox"/>	4. Light Red Window Trim	1730
<input type="checkbox"/>	5. Black Detail	0020
<input type="checkbox"/>	6. Cover Stitch & Lace.....	1800
<input type="checkbox"/>	7. Silver Detail	7009
<input type="checkbox"/>	8. Gold Detail.....	7014

12564-09 Pagoda Ceiling 2 FSL

Size Inches: Size mm: Stitch Count:
2.31 X 2.31 in. 58.67 X 58.67 mm 5924 St.

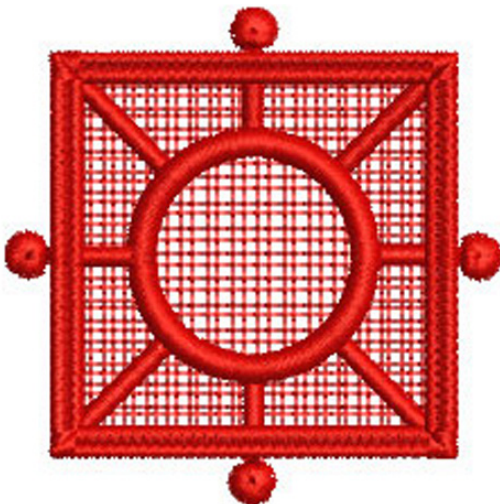

<input type="checkbox"/>	1. Single Color Design.....	1800
--------------------------	-----------------------------	------

Note: Some designs in this collection may have been created using unique special stitches and/or techniques. To preserve design integrity when rescaling or rotating designs in your software, always rescale or rotate designs using the handles directly on-screen.

*Fabric Required

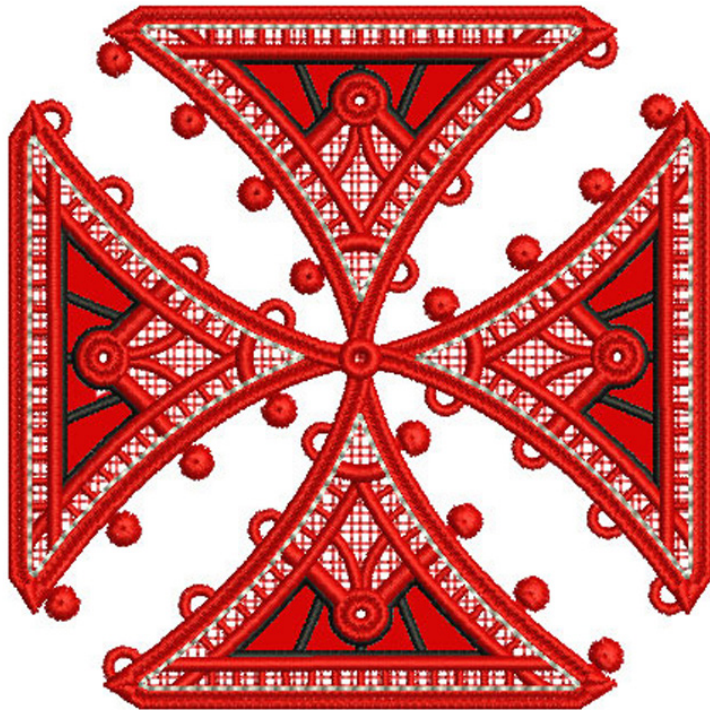

12564-10 Pagoda Roof FSA

Size Inches: Size mm: Stitch Count:
4.34 X 4.34 in. 110.24 X 110.24 mm 33149 St.

■	1. Placement Stitch	1800
■	2. Cut Line & Tackdown.....	1800
■	3. Black Detail	0020
■	4. Cover Stitch & Lace.....	1800
■	5. Silver Detail	7009

COLLECTION SUPPLIES



Stabilizer

- AquaMesh WashAway
- BadgeMaster WashAway
- StabilStick TearAway

Supplies

- Expert Embroidery WashAway Tape
- Alligator Clamps
- Button Clips
- Perfect Embroidery Press Cloth
- ¼ yd. Red cotton fabric
- Threads per the design

INSTRUCTIONS



TIPS

- 2 pieces of StabilStick TearAway on the back of each applique fabric.
- Matching bobbin for all lace and coverstitches.
- 1 layer of AquaMesh and 1 layer of Badgemaster for stiffer lace.
- Anytime there is a placement line in the design, this means it's applique, and fabric is placed next.
- Label each piece to make it easier to put together.
- These steps are for design 1, but these instructions apply to the rest of the design as well. There are two lace only designs in this project. (designs 12564-07 and 12564-09)

STEP 1

- Hoop 1 layer of AquaMesh and 1 layer of BadgeMaster.
- Wind one bobbin with White thread and 1 bobbin with 1800 Red.
- Thread machine with 0015 and insert the white bobbin.



STEP 2

- Stitch Machine Step 1, Applique placement.

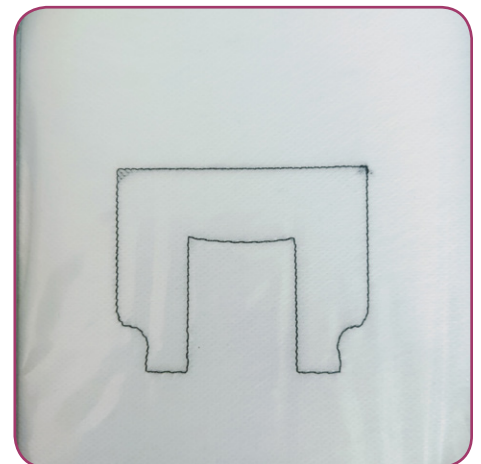

INSTRUCTIONS



STEP 3

- Adhere the 2 pieces of StabilStick to the wrong side of the applique fabric.
- This is done to create stiffness in the project.

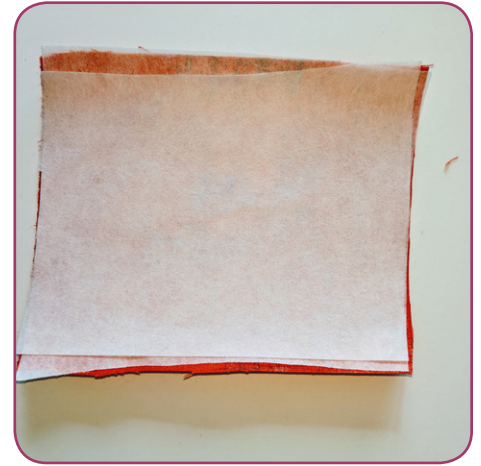

STEP 4

- Place the applique fabric, right side up, over the placement stitch. Tape in place.



STEP 5

- Stitch Machine Step 2, the Cutline and Tackdown stitch.

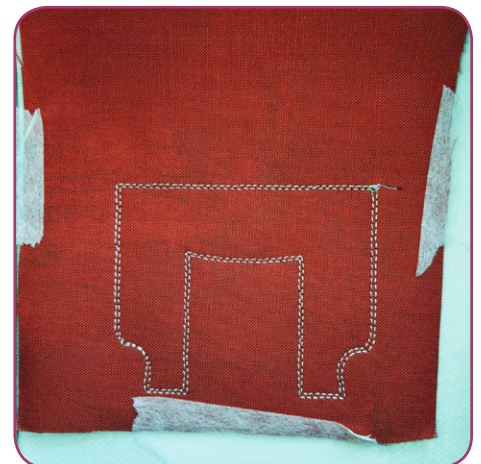

INSTRUCTIONS



STEP 6

- Remove the project from the machine, but do not remove the project from the hoop.
- Trim close to the stitching.
- Return the hoop to the machine.



STEP 7

- Stitch Machine Step 3, the flowers.
- Stitch Machine Step 4, the lace door.
- Thread the machine with 1730.
- Stitch Machine Step 5, swirls.
- Stitch Machine Step 6, the door trim.
- Thread machine with 0020.
- Stitch Machine Step 7, black detail.



STEP 8

- Thread the machine with 1800. Insert the red bobbin.
- Stitch Machine Step 8, the Coverstitch and Lace.
- Thread machine with 7014. Stitch Machine Step 9, gold details.



INSTRUCTIONS



STEP 9

- Remove the design from the hoop. Trim stabilizers approximately ¼" from the edges.



STEP 10

- Rinse in warm running water.



STEP 11

- The more stabilizer rinsed out, the less stiff the final product will be. Rinse until it is just slightly tacky. Lay flat to dry.
- Press right side down into a Perfect Press Cloth.
- Set aside. Continue stitching the rest of the designs. Change to the red bobbin each time you are doing the coverstitch and lace.



STEP 12

- One of each design is required, except for designs 12564-06 and 12564-08, which need 4 each.

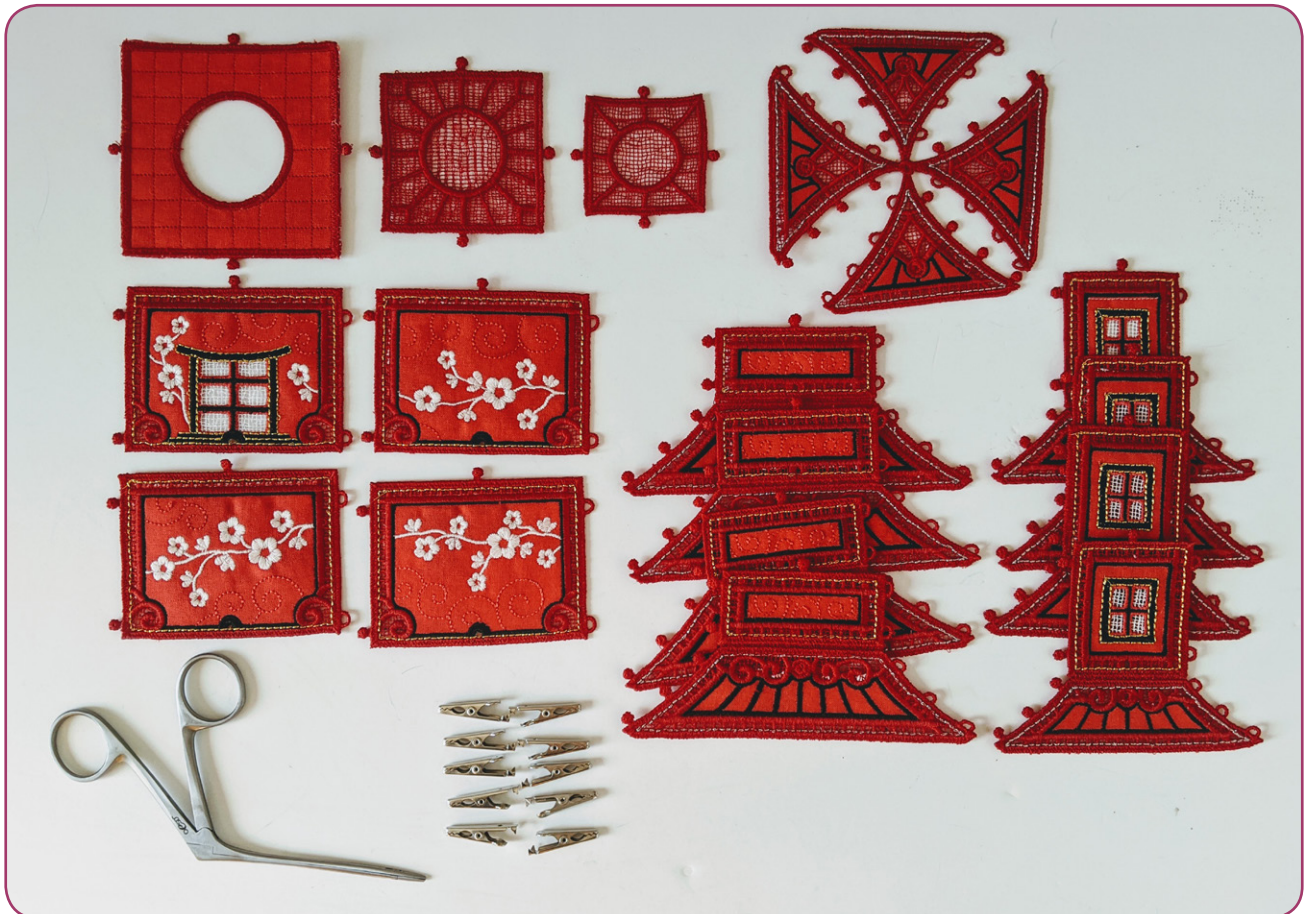

STEP 13

- Attach the Pagoda Front Wall FSA (12564- 01) to the Pagoda Left Wall FSA (12564-02) side by side by inserting the two buttonettes along the left side into the two eyelets on the right side. Continue attaching the Pagoda Back Wall FSA (12564-03) and the Pagoda Right Wall FSA (12564-04) pieces together in the same manner creating a flat piece.



ASSEMBLY



STEP 14

- Attach the Pagoda Foundation FSA (12564-05) by inserting the buttonettes of the foundation into the eyelets along the bottom of the pagoda walls.
- Attach the remaining side of the pagoda walls to form a square. Set aside.
- **Tip: Use button clips to hold walls in place while assembling.**



STEP 15

- Attach a Pagoda Roof & Wall 1 FSA (12564-06) to another Pagoda Roof & Wall 1 FSA (12564-06) by inserting the five buttonettes along the left side into the five eyelets on the right side. Continue attaching the Pagoda Roof & Walls 1 together in the same manner creating an open piece.



STEP 16

- Attach the Pagoda Ceiling 1 FSL (12564-07) to the Pagoda Roof & Wall 1 section by pulling the buttonettes from the ceiling piece into the corresponding eyelets on the middle section of the pagoda roof & wall 1 section. Attach the remaining side of the Pagoda Roof & Walls 1 to form a square. Set aside.

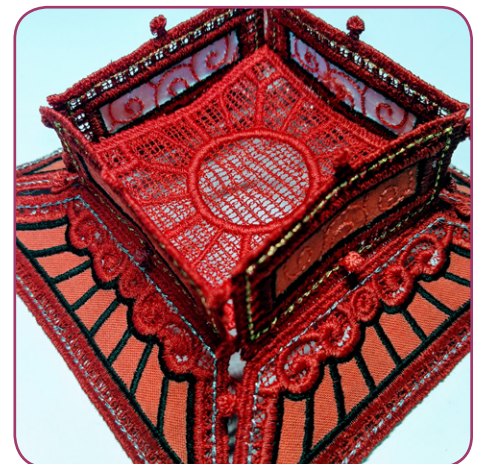

ASSEMBLY



STEP 17

- Attach a Pagoda Roof & Wall 2 FSA (12564-08) to another Pagoda Roof & Wall 2 FSA (12564-08) by inserting the five buttonettes along the left side into the five eyelets on the right side. Continue attaching the Pagoda Roof & Walls 2 together in the same manner creating an open piece.



STEP 18

- Attach the Pagoda Ceiling 2 FSL (12564-09) to the Pagoda Roof & Wall 2 section by pulling the buttonettes from the ceiling piece into the corresponding eyelets on the middle section of the pagoda roof & wall 2 section. Attach the remaining side of the Pagoda Roof & Walls to form a square. Set aside.



ASSEMBLY



STEP 19

- Attach a Pagoda Roof FSA (12564-10) triangle side to another side by inserting the four buttonettes along the left side into the four eyelets on the right side. Continue for all sides, using button clips as needed. Set aside.



STEP 20

- Attach the pagoda walls section to the Pagoda Roof & Walls 1 section by pulling the buttonettes from the top of the walls into the corresponding eyelets on the Roof & Walls 1 section.



ASSEMBLY



STEP 21

- Continue building the pagoda by attaching the previous pagoda section to the Pagoda Roof & Wall 2 section by pulling the buttonettes from the Pagoda Roof & Wall 1 section into the corresponding eyelets on the Pagoda Roof & Wall 2 section.



STEP 22

- Attach the Pagoda Roof FSL piece to the top of the pagoda by pulling the buttonettes from the Pagoda Roof & Wall 2 into the corresponding eyelets on the Pagoda Roof.



ASSEMBLY



STEP 23

- The pagoda is complete!



APPLIQUE PATTERNS

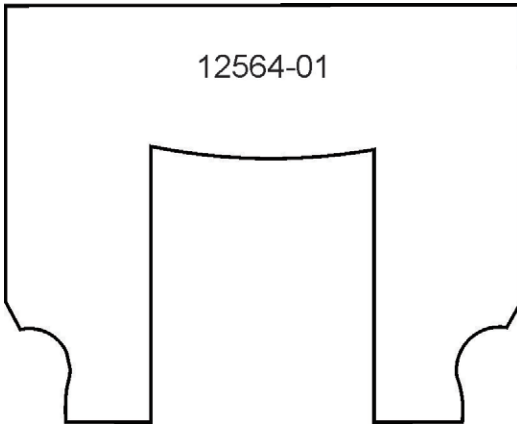

12564-01

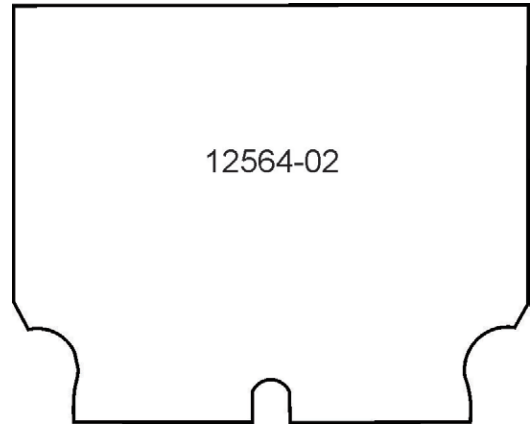

12564-02

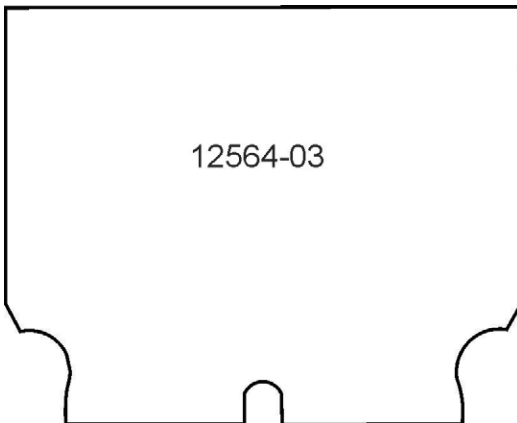

12564-03

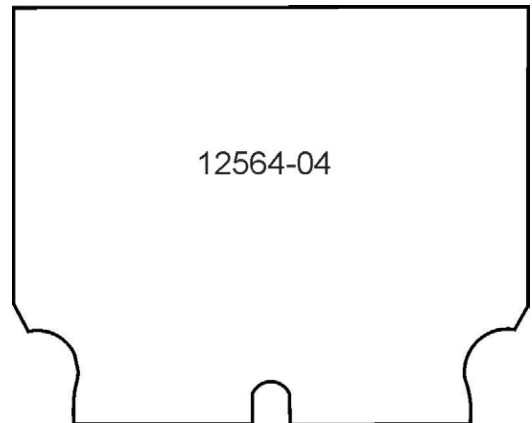

12564-04

APPLIQUE PATTERNS

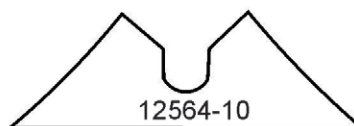
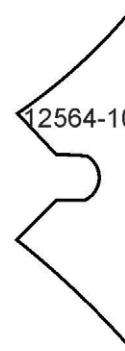
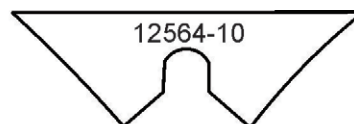
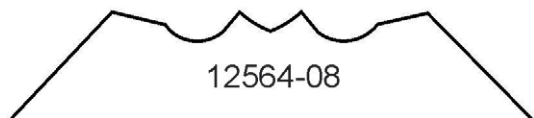
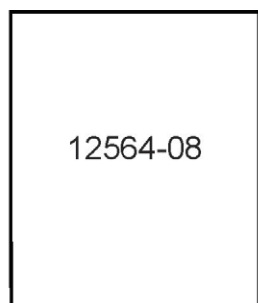
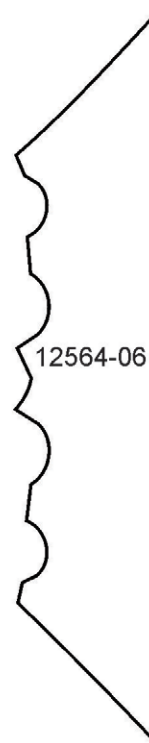
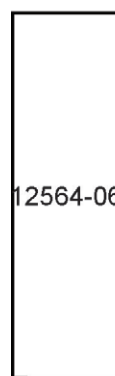
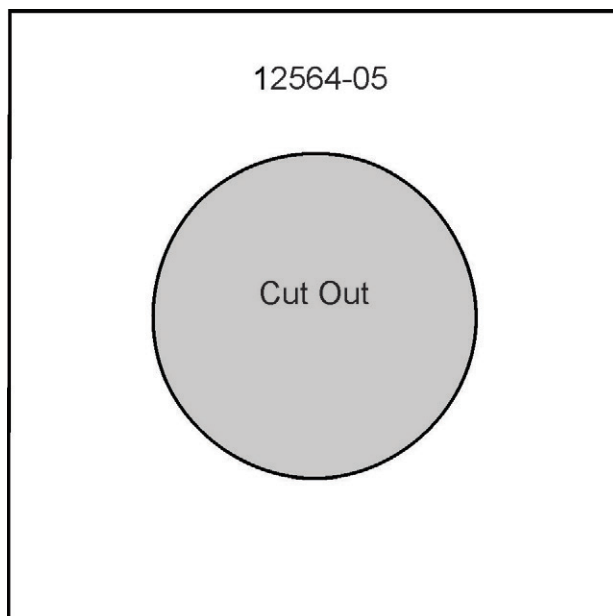

MIRRORED PATTERNS

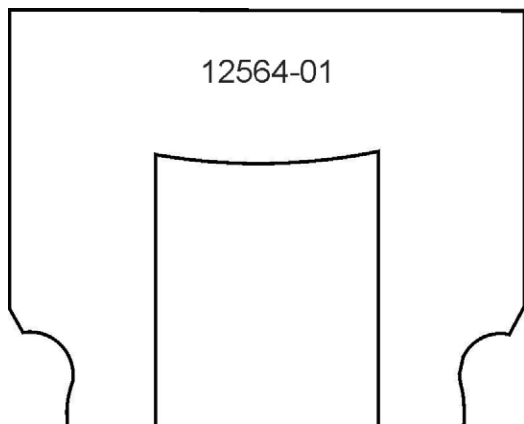

12564-01

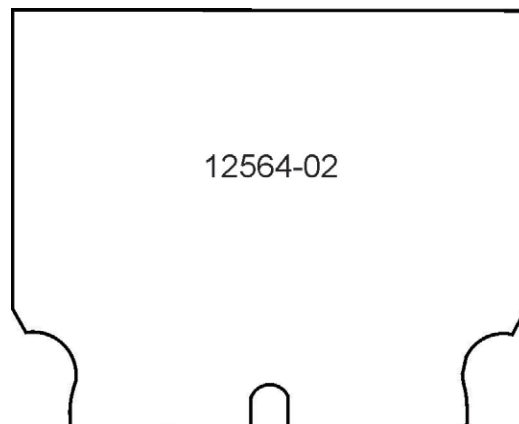

12564-02

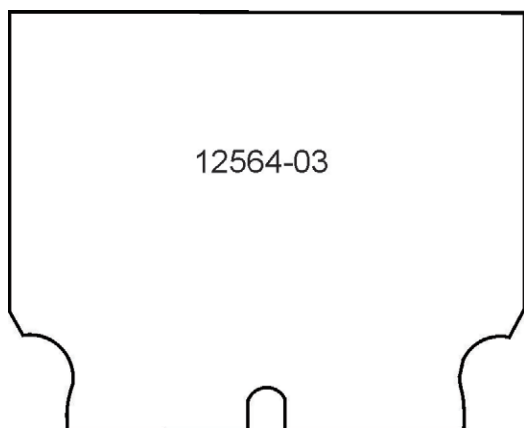

12564-03

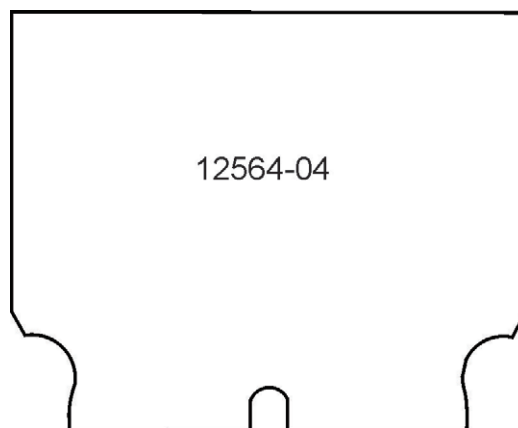

12564-04

MIRRORED PATTERNS

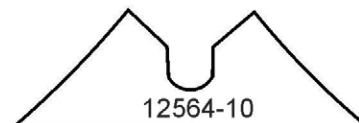
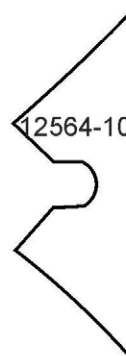
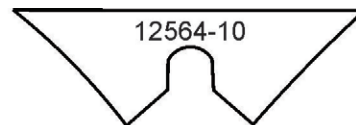
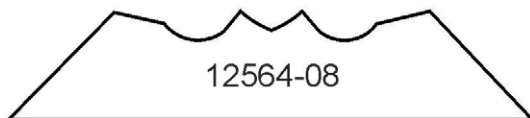
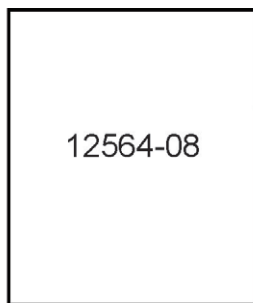
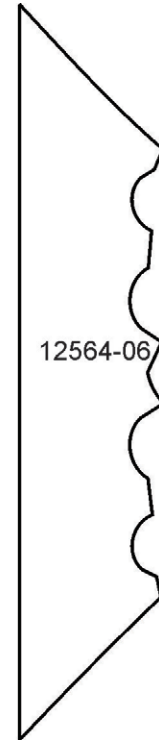
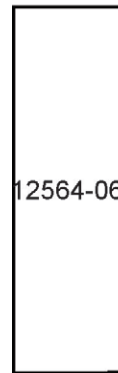
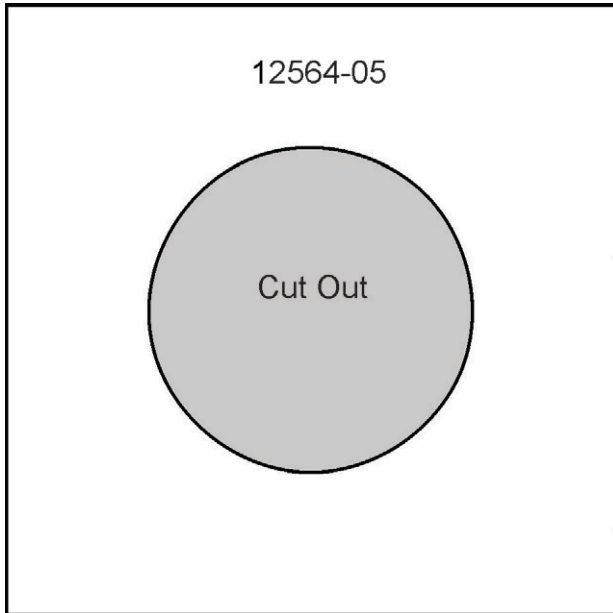

General Freestanding Lace Guidelines

Supplies:

Embroidery Thread:

- Use the same embroidery thread in the bobbin as the needle.

Needles:

- Use an Organ 80/12 Titanium needle for extended needle life.

Stabilizer:

- Use OESD AquaMesh stabilizer.
- Use OESD BadgeMaster stabilizer.

Handy Hints:

For Stiffer Lace:

- DO NOT rinse away all of the stabilizer for a “stiffer” lace. Note that the thread may appear a shade darker if stabilizer is not removed completely.
- If you happen to wash too much out, easily re-stiffen by diluting some stabilizer scraps in water and dipping the item in the solution.

For Very Soft Lace:

- Cut away excess stabilizer. Remove remaining stabilizer by rinsing under warm running water until all traces of the stabilizer are gone. **NOTE:** If lace should become too limp to work with, dissolve stabilizer scraps in warm water and apply to the lace.

Drying Lace:

- The lace looks best when left to dry completely. Lay lace piece with right side down to dry. This will minimize the tendency for the lace to curl. Be sure to flatten the piece out entirely and allow ample time to dry.

General Instructions

1. Hoop one layer of OESD AquaMesh and BadgeMaster Stabilizer.
2. Attach the hoop to the machine and select the design of your choice.
3. Stitch the design.
4. Remove the hoop from the machine and the design from the hoop. Trim excess stabilizer from the design.
5. Rinse away remaining stabilizer and allow it to dry.

Handy Hints:

For 3D Lace Projects:

- If item becomes too limp to work with, iron the lace pieces on the wrong side while applying spray starch. After ironing, spray again with starch and allow to dry completely. This will stiffen the lace pieces nicely and aid in construction.
- A pair of tweezers, hemostats, stiletto or a tiny crochet hook can be extremely helpful when inserting the buttonettes into the eyelets. (Please see **Diagram 1** for explanation of “buttonette” and “eyelet”.)
- Insert the tip of the alligator clamps, tweezers, hemostats or crochet hook into the eyelet, grasp the buttonette and pull through the eyelet. Or a stiletto could be used to push the buttonette through the eyelet.

Diagram 1

