

#12599

- 21 Applique files
- 15 Freestanding lace files
- Project instructions included



3
DESIGNS

Freestanding Snowmen

THREAD LIST



Isacord Thread Colors

- 0015 White
- 0020 Black
- 0112 Leadville
- 0811 Candlelight
- 1010 Toast
- 1055 Bark
- 1366 Mahogany
- 4174 Charcoal
- 4250 Snomoon

DESIGNS

Note: Some designs in this collection may have been created using unique special stitches and/or techniques. To preserve design integrity when rescaling or rotating designs in your software, always rescale or rotate designs using the handles directly on-screen.

12599-01 Chevron Snowman Bottom Sections FSA

*Fabric Required

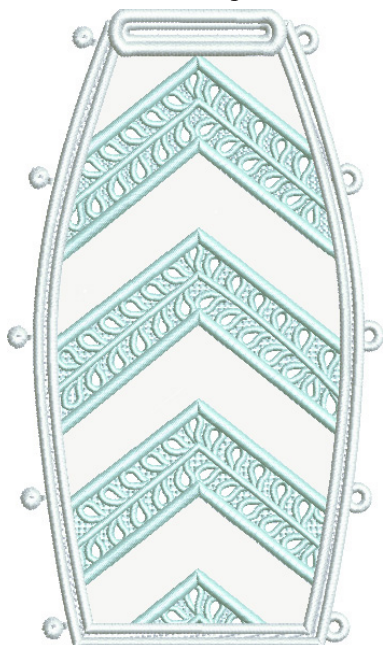

Size Inches:	Size mm:	Stitch Count:
3.65 X 6.24 in.	92.71 X 158.50 mm	37,872 St.

- | | | |
|-------------------------------------|--|------|
| <input type="checkbox"/> | 1. Bottom Slice Placement Stitch | 0015 |
| <input type="checkbox"/> | 2. Cut Line and Tackdown | 0015 |
| <input checked="" type="checkbox"/> | 3. Chevron Lace | 4250 |
| <input type="checkbox"/> | 4. Lace..... | 0015 |

Note: Some designs in this collection may have been created using unique special stitches and/or techniques. To preserve design integrity when rescaling or rotating designs in your software, always rescale or rotate designs using the handles directly on-screen.

12599-02 Chevron Snowman Middle Back Section FSA

*Fabric Required



Size Inches: Size mm: Stitch Count:
4.98 X 4.80 in. 126.49 X 121.92 mm 48,577 St.

- 1. Middle Slice Placement Stitch 0015
- 2. Cut Line and Tackdown 0015
- 3. Chevron Lace 4250
- 4. Lace..... 0015

12599-03 Chevron Middle Left Section FSA

*Fabric Required



Size Inches: Size mm: Stitch Count:
4.98 X 4.81 in. 126.49 X 122.17 mm 49,234 St.

- 1. Middle Slice Placement Stitch 0015
- 2. Cut Line and Tackdown 0015
- 3. Chevron Lace 4250
- 4. Lace..... 0015

Note: Some designs in this collection may have been created using unique special stitches and/or techniques. To preserve design integrity when rescaling or rotating designs in your software, always rescale or rotate designs using the handles directly on-screen.

12599-04 Chevron Middle Right Section FSA

*Fabric Required

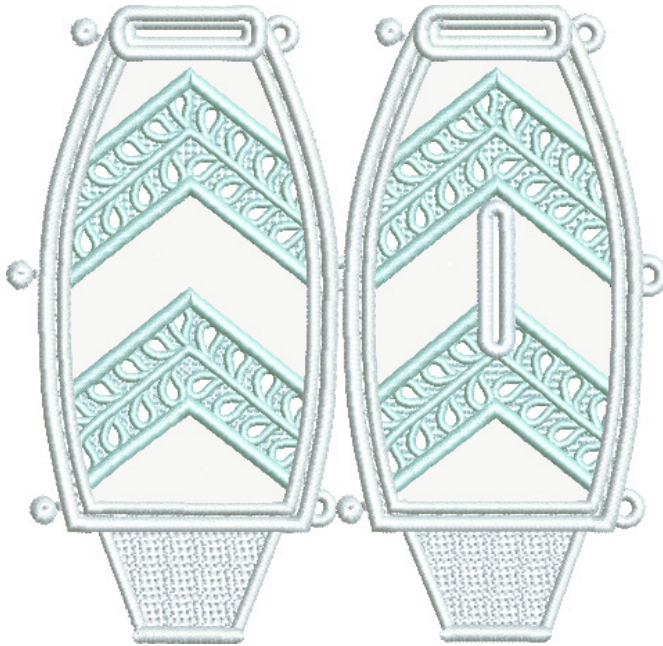

Size Inches: Size mm: Stitch Count:
4.98 X 4.82 in. 126.49 X 122.43 mm 48,673 St.

- 1. Middle Slice Placement Stitch 0015
- 2. Cut Line and Tackdown 0015
- 3. Chevron Lace 4250
- 4. Lace 0015

12599-05 Snowman Head Left Section with Carrot FSA

*Fabric Required

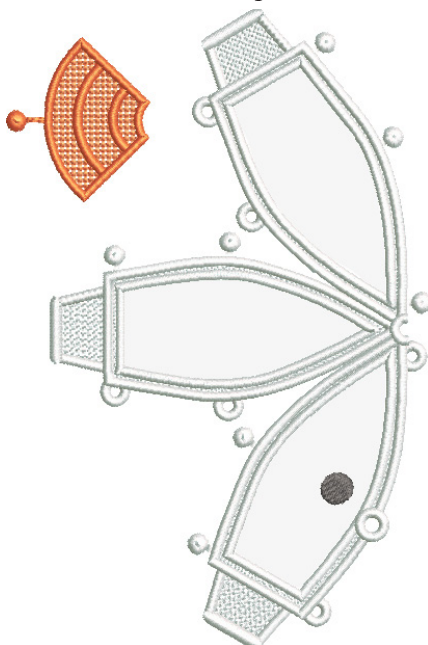

Size Inches: Size mm: Stitch Count:
4.27 X 6.42 in. 108.45 X 163.07 mm 21,074 St.

- 1. Head Placement Stitch 0015
- 2. Cut Line and Tackdown 0015
- 3. Head Lace 0015
- 4. Eye 4174
- 5. Lace Carrot 1010

Note: Some designs in this collection may have been created using unique special stitches and/or techniques. To preserve design integrity when rescaling or rotating designs in your software, always rescale or rotate designs using the handles directly on-screen.

12599-06 Snowman Head Right Section FSA

*Fabric Required

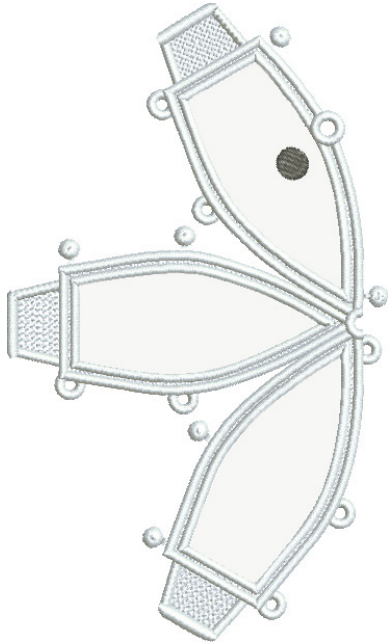

Size Inches:	Size mm:	Stitch Count:
3.83 X 6.41 in.	97.28 X 162.81 mm	18,335 St.

- | | | |
|-------------------------------------|--------------------------------|------|
| <input type="checkbox"/> | 1. Head Placement Stitch | 0015 |
| <input type="checkbox"/> | 2. Cut Line and Tackdown | 0015 |
| <input type="checkbox"/> | 3. Head Lace | 0015 |
| <input checked="" type="checkbox"/> | 4. Eye | 4174 |

12599-07 Snowman Base FSA

*Fabric Required

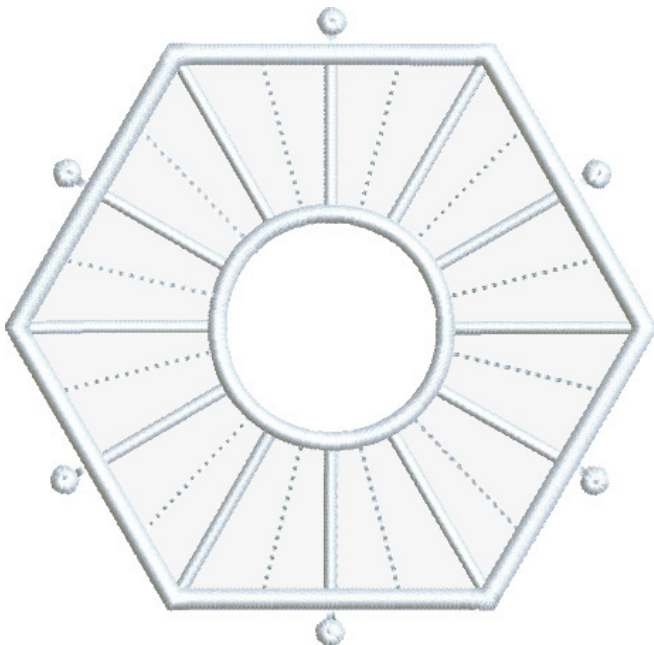

Size Inches:	Size mm:	Stitch Count:
4.81 X 4.72 in.	122.17 X 119.89 mm	9,085 St.

- | | | |
|--------------------------|---------------------------------|------|
| <input type="checkbox"/> | 1. Base Placement Stitch | 0015 |
| <input type="checkbox"/> | 2. Cut Line and Tackdown | 0015 |
| <input type="checkbox"/> | 3. Cover Stitch and Detail..... | 0015 |

Note: Some designs in this collection may have been created using unique special stitches and/or techniques. To preserve design integrity when rescaling or rotating designs in your software, always rescale or rotate designs using the handles directly on-screen.

12599-08 Blank Top Hat Sides FSL

Size Inches:	Size mm:	Stitch Count:
4.59 X 4.82 in.	116.59 X 122.43 mm	40,418 St.

■ 1. Hat Sides..... 0020

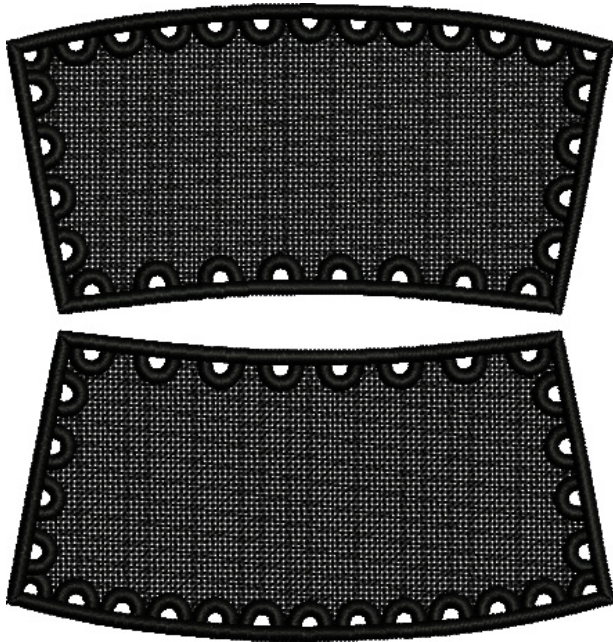

12599-09 Blank Top Hat Brim FSL

Size Inches:	Size mm:	Stitch Count:
4.44 X 4.80 in.	112.78 X 121.92 mm	27,300 St.

■ 1. Hat Brim 0020

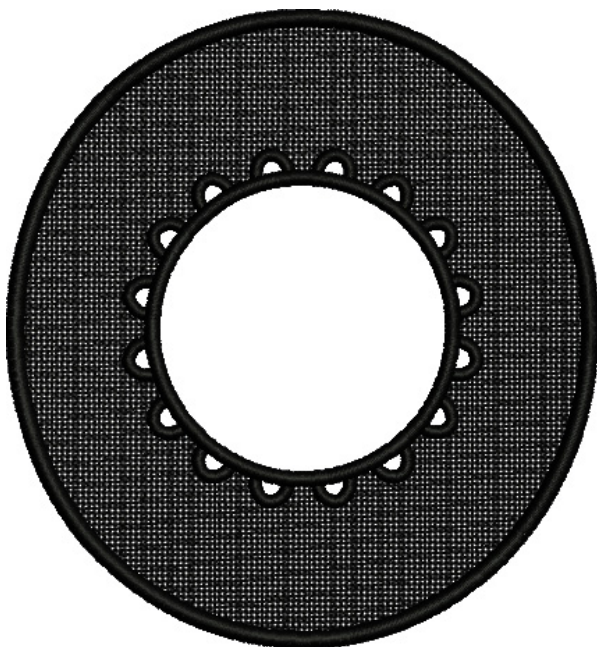

Note: Some designs in this collection may have been created using unique special stitches and/or techniques. To preserve design integrity when rescaling or rotating designs in your software, always rescale or rotate designs using the handles directly on-screen.

12599-10 Blank Top Hat Top FSL

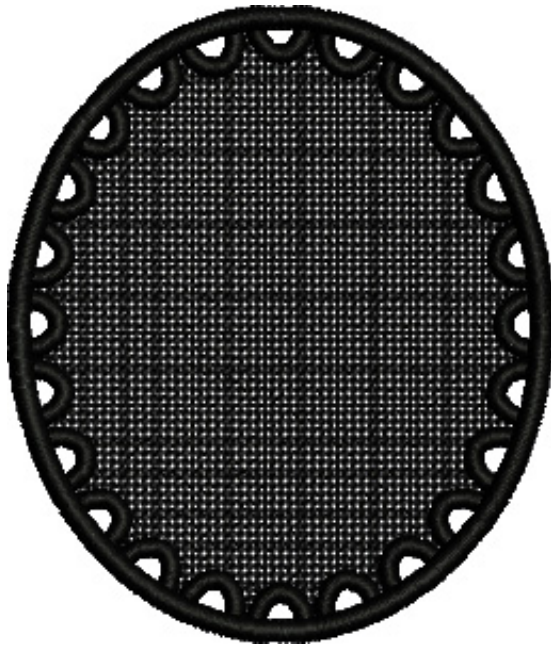

Size Inches:	Size mm:	Stitch Count:
2.67 X 3.13 in.	67.82 X 79.50 mm	14,393 St.
■ 1. Hat Top		0020

12599-11 Left Arm Branch FSL



Size Inches:	Size mm:	Stitch Count:
4.48 X 4.82 in.	113.79 X 122.43 mm	11,196 St.
■ 1. Left Arm Branch.....		1366

Note: Some designs in this collection may have been created using unique special stitches and/or techniques. To preserve design integrity when rescaling or rotating designs in your software, always rescale or rotate designs using the handles directly on-screen.

12599-12 Right Arm Branch FSL

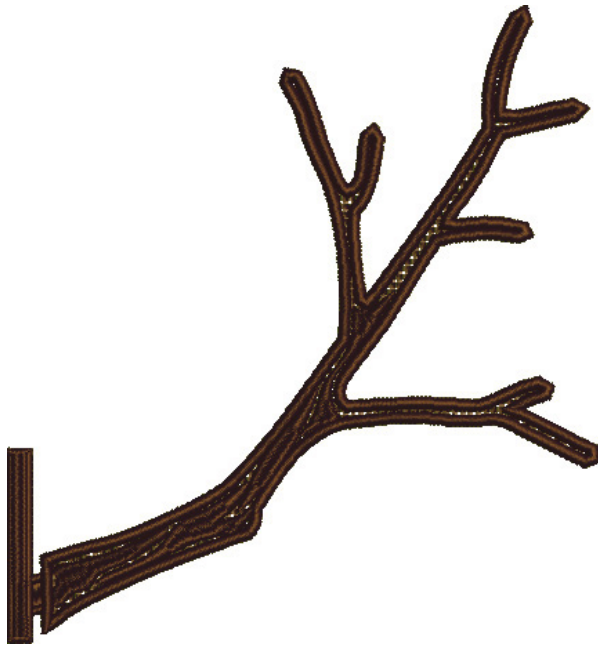

Size Inches:	Size mm:	Stitch Count:
4.48 X 4.82 in.	113.79 X 122.43 mm	11,196 St.

■ 1. Right Arm Branch	1366
-----------------------------	------

12599-13 Snowflake Snowman Bottom Sections FSA

*Fabric Required



Size Inches:	Size mm:	Stitch Count:
3.66 X 6.19 in.	92.96 X 157.23 mm	25,517 St.

□ 1. Bottom Slice Placement Stitch	0015
□ 2. Cut Line and Tackdown	0015
■ 3. Snowflakes and Swirls	4250
□ 4. Lace.....	0015

Note: Some designs in this collection may have been created using unique special stitches and/or techniques. To preserve design integrity when rescaling or rotating designs in your software, always rescale or rotate designs using the handles directly on-screen.

12599-14 Snowflake Snowman Middle Back Section FSA

*Fabric Required

Size Inches: Size mm: Stitch Count:
 4.99 X 4.82 in. 126.75 X 122.43 mm 26,271 St.

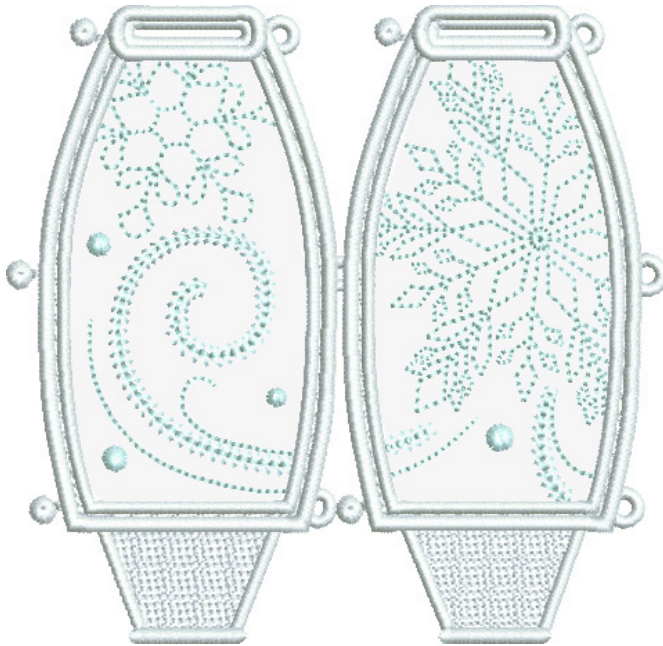

- 1. Middle Slices Placement Stitch 0015
- 2. Cut Line and Tackdown 0015
- 3. Snowflakes and Swirls 4250
- 4. Lace..... 0015

12599-15 Snowflake Snowman Middle Left Section FSA

*Fabric Required

Size Inches: Size mm: Stitch Count:
 4.99 X 4.82 in. 126.75 X 122.43 mm 27,462 St.

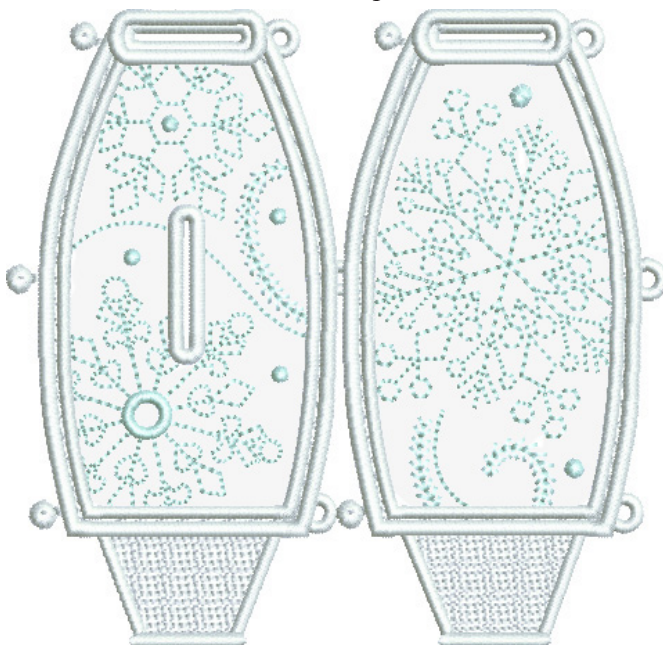

- 1. Middle Slices Placement Stitch 0015
- 2. Cut Line and Tackdown 0015
- 3. Snowflakes and Swirls 4250
- 4. Lace..... 0015

Note: Some designs in this collection may have been created using unique special stitches and/or techniques. To preserve design integrity when rescaling or rotating designs in your software, always rescale or rotate designs using the handles directly on-screen.

12599-16 Snowflake Snowman Middle Right Section FSA

*Fabric Required



Size Inches: 4.99 X 4.82 in. Size mm: 126.75 X 122.43 mm Stitch Count: 27,051 St.

- 1. Middle Slices Placement Stitch 0015
- 2. Cut Line and Tackdown 0015
- 3. Snowflakes and Swirls 4250
- 4. Lace 0015

12599-17 Snowman Head Left Section with Carrot FSA

*Fabric Required

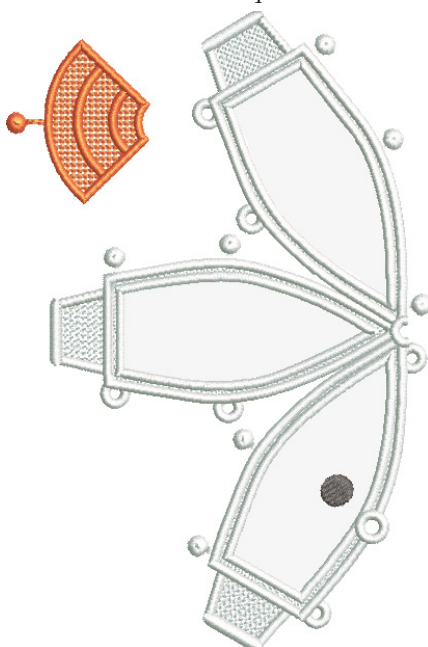

Size Inches: 4.20 X 6.42 in. Size mm: 106.68 X 163.07 mm Stitch Count: 21,074 St.

- 1. Head Placement Stitch 0015
- 2. Cut Line and Tackdown 0015
- 3. Head Lace 0015
- 4. Eye 4174
- 5. Lace Carrot 1010

Note: Some designs in this collection may have been created using unique special stitches and/or techniques. To preserve design integrity when rescaling or rotating designs in your software, always rescale or rotate designs using the handles directly on-screen.

12599-18 Snowman Head Right Section FSA

*Fabric Required

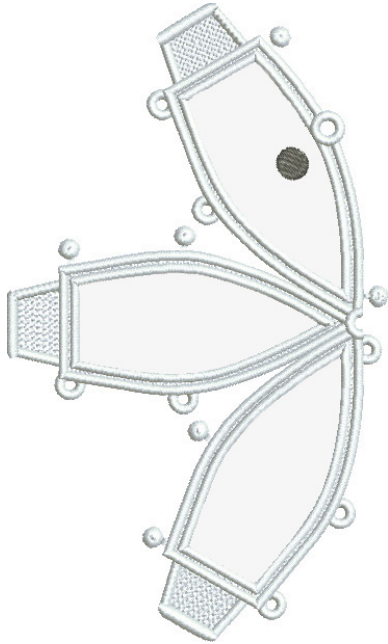

Size Inches: Size mm: Stitch Count:
 3.83 X 6.41 in. 97.28 X 162.81 mm 18,335 St.

- 1. Head Placement Stitch 0015
- 2. Cut Line and Tackdown 0015
- 3. Head Lace 0015
- 4. Eye 4174

12599-19 Snowman Base FSA

*Fabric Required

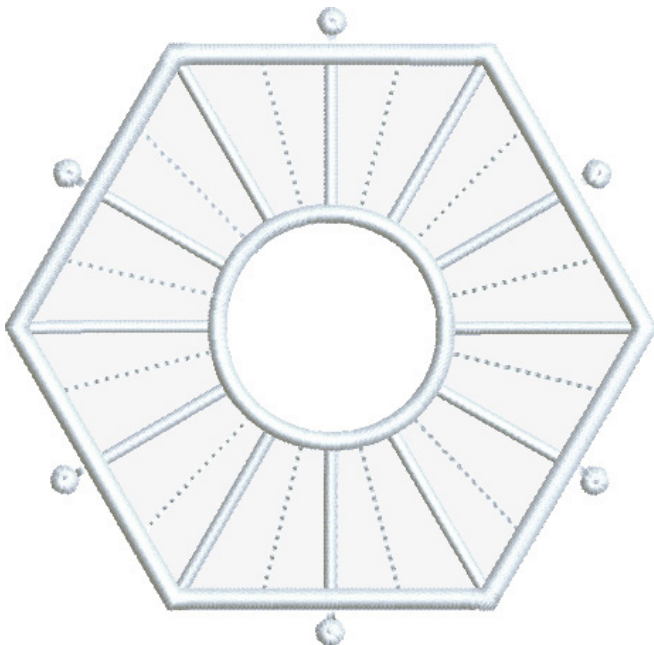

Size Inches: Size mm: Stitch Count:
 4.81 X 4.72 in. 122.17 X 119.89 mm 9,100 St.

- 1. Base Placement Stitch 0015
- 2. Cut Line and Tackdown 0015
- 3. Cover Stitch and Detail..... 0015

Note: Some designs in this collection may have been created using unique special stitches and/or techniques. To preserve design integrity when rescaling or rotating designs in your software, always rescale or rotate designs using the handles directly on-screen.

12599-20 Swirly Top Hat Sides FSL



Size Inches:	Size mm:	Stitch Count:
4.59 X 4.82 in.	116.59 X 122.43 mm	46,779 St.

■ 1. Hat Sides..... 4174

12599-21 Swirly Top Hat Brim FSL

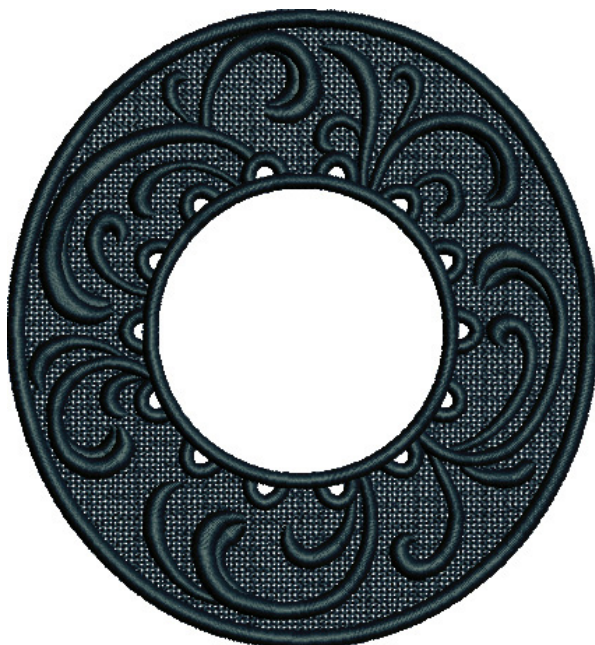

Size Inches:	Size mm:	Stitch Count:
4.42 X 4.78 in.	112.27 X 121.41 mm	34,021 St.

■ 1. Hat Brim 4174

Note: Some designs in this collection may have been created using unique special stitches and/or techniques. To preserve design integrity when rescaling or rotating designs in your software, always rescale or rotate designs using the handles directly on-screen.

12599-22 Swirly Top Hat Top FSL

Size Inches:	Size mm:	Stitch Count:
2.67 X 3.13 in.	67.82 X 79.50 mm	17,336 St.

■ 1. Hat Top 4174



12599-23 Left Arm Branch FSL

Size Inches:	Size mm:	Stitch Count:
4.48 X 4.82 in.	113.79 X 122.43 mm	11,196 St.

■ 1. Left Arm Branch..... 1366



Note: Some designs in this collection may have been created using unique special stitches and/or techniques. To preserve design integrity when rescaling or rotating designs in your software, always rescale or rotate designs using the handles directly on-screen.

12599-24 Right Arm Branch FSL



Size Inches:	Size mm:	Stitch Count:
4.48 X 4.82 in.	113.79 X 122.43 mm	11,196 St.

■ 1. Right Arm Branch 1366

12599-25 Blank Snowman Bottom Sections FSA

*Fabric Required

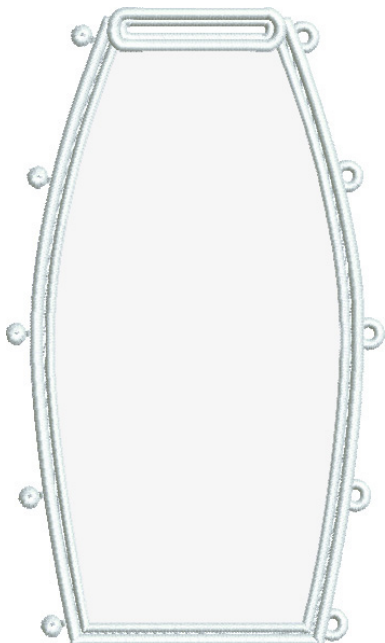

Size Inches:	Size mm:	Stitch Count:
3.66 X 6.23 in.	92.96 X 158.24 mm	13,321 St.

1. Bottom Slice Placement Stitch 0015
 2. Cut Line and Tackdown 0015
 3. Lace..... 0015

Note: Some designs in this collection may have been created using unique special stitches and/or techniques. To preserve design integrity when rescaling or rotating designs in your software, always rescale or rotate designs using the handles directly on-screen.

12599-26 Blank Snowman Middle Back Section FSA

*Fabric Required

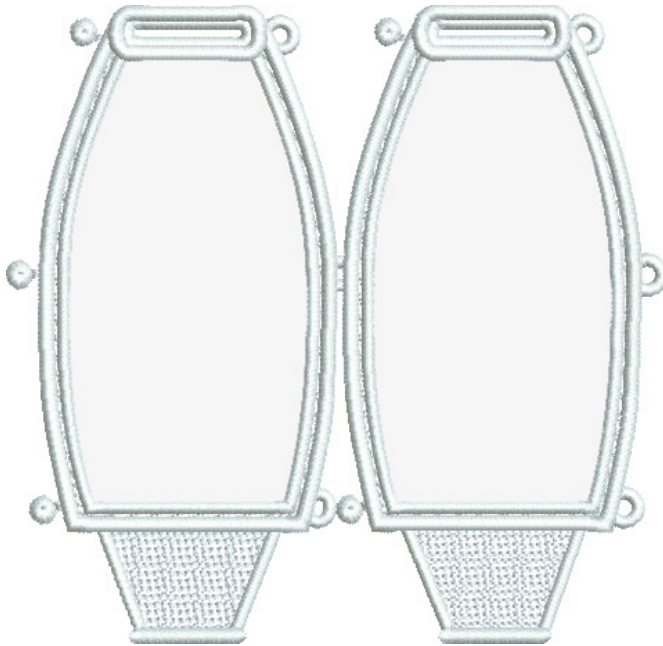

Size Inches:	Size mm:	Stitch Count:
4.99 X 4.82 in.	126.75 X 122.43 mm	21,439 St.

- 1. Middle Slices Placement Stitch 0015
- 2. Cut Line and Tackdown 0015
- 3. Lace..... 0015

12599-27 Blank Snowman Middle Left Section FSA

*Fabric Required

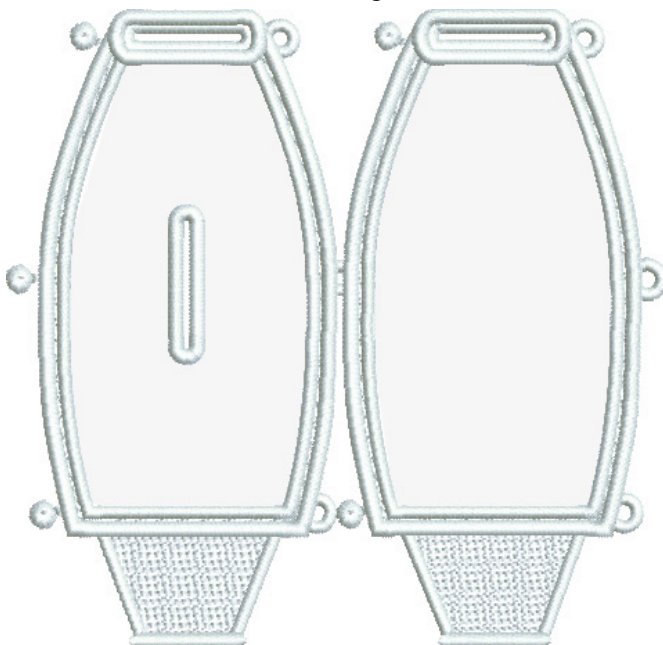

Size Inches:	Size mm:	Stitch Count:
4.99 X 4.82 in.	126.75 X 122.43 mm	21,608 St.

- 1. Middle Slices Placement Stitch 0015
- 2. Cut Line and Tackdown 0015
- 3. Lace..... 0015

Note: Some designs in this collection may have been created using unique special stitches and/or techniques. To preserve design integrity when rescaling or rotating designs in your software, always rescale or rotate designs using the handles directly on-screen.

12599-28 Blank Snowman Middle Right Section FSA

*Fabric Required

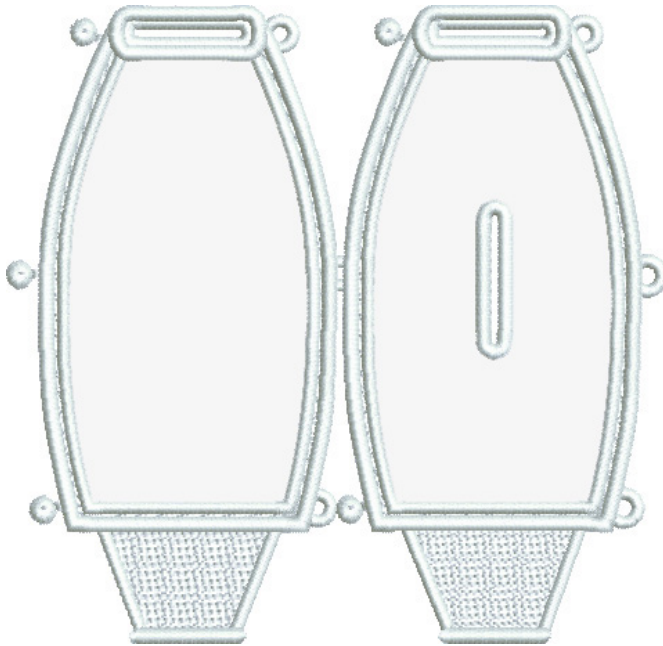

Size Inches:	Size mm:	Stitch Count:
4.99 X 4.82 in.	126.75 X 122.43 mm	21,622 St.

- 1. Middle Slices Placement Stitch 0015
- 2. Cut Line and Tackdown 0015
- 3. Lace..... 0015

12599-29 Snowman Head Left Section with Carrot FSA

*Fabric Required

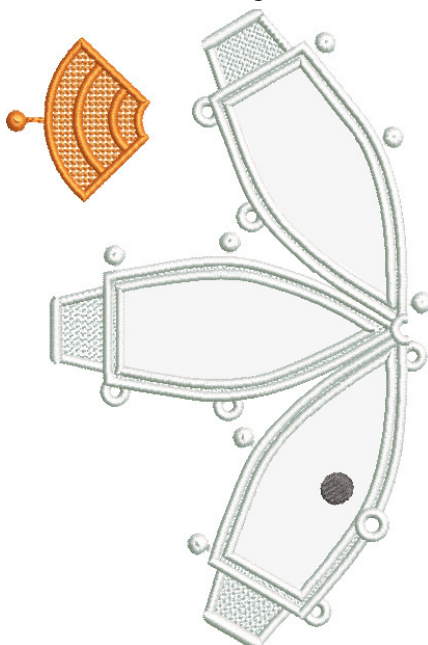

Size Inches:	Size mm:	Stitch Count:
4.14 X 6.42 in.	105.15 X 163.07 mm	21,074 St.

- 1. Head Placement Stitch 0015
- 2. Cut Line and Tackdown 0015
- 3. Head Lace 0015
- 4. Eye 4174
- 5. Lace Carrot.....0811

Note: Some designs in this collection may have been created using unique special stitches and/or techniques. To preserve design integrity when rescaling or rotating designs in your software, always rescale or rotate designs using the handles directly on-screen.

12599-30 Snowman Head Right Section FSA

*Fabric Required

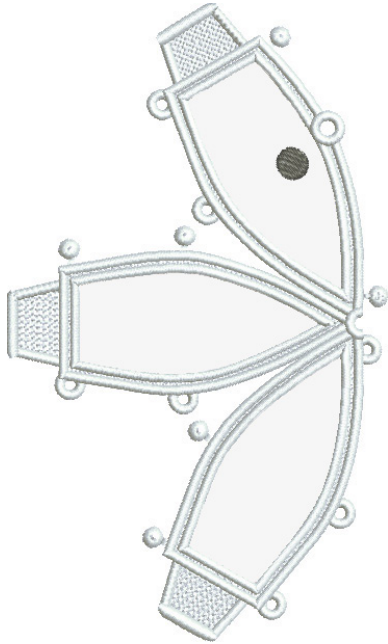

Size Inches: Size mm: Stitch Count:
3.83 X 6.41 in. 97.28 X 162.81 mm 18,335 St.

- 1. Head Placement Stitch 0015
- 2. Cut Line and Tackdown 0015
- 3. Head Lace 0015
- 4. Eye 4174

12599-31 Snowman Base FSA

*Fabric Required

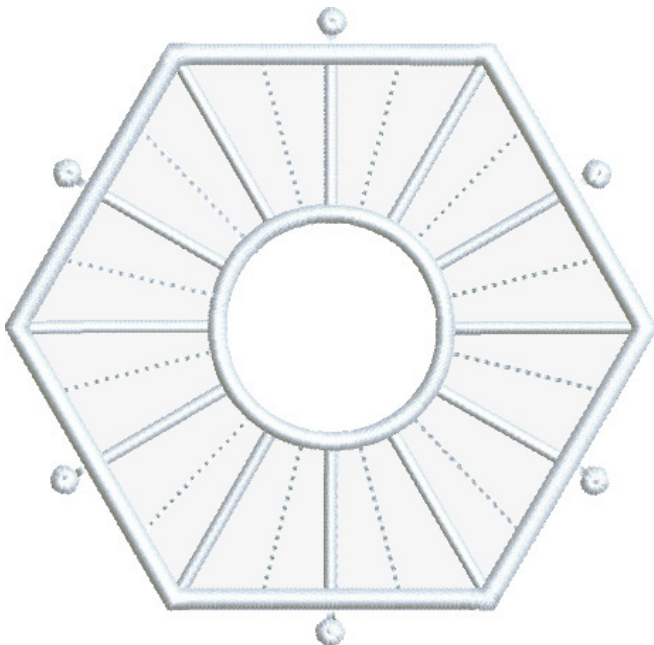

Size Inches: Size mm: Stitch Count:
4.81 X 4.72 in. 122.17 X 119.89 mm 9,100 St.

- 1. Base Placement Stitch 0015
- 2. Cut Line and Tackdown 0015
- 3. Cover Stitch and Detail..... 0015

Note: Some designs in this collection may have been created using unique special stitches and/or techniques. To preserve design integrity when rescaling or rotating designs in your software, always rescale or rotate designs using the handles directly on-screen.

12599-32 Swirly Top Hat Sides FSL

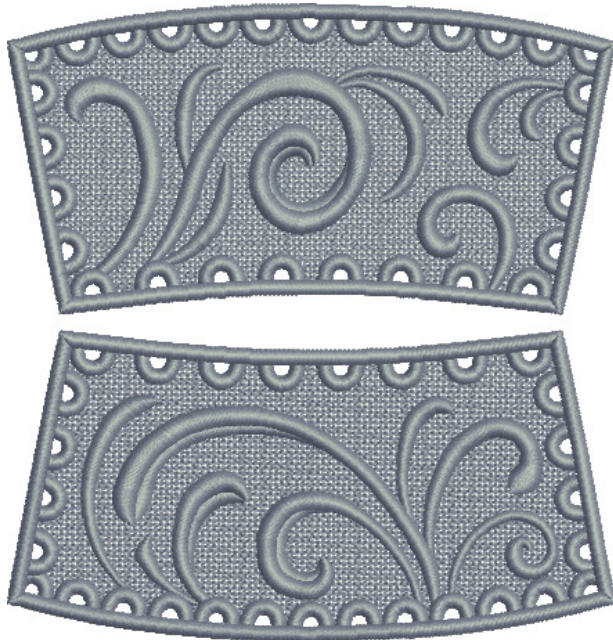

Size Inches:	Size mm:	Stitch Count:
4.59 X 4.82 in.	116.59 X 122.43 mm	46,779 St.

■ 1. Hat Sides.....0112

12599-33 Swirly Top Hat Brim FSL

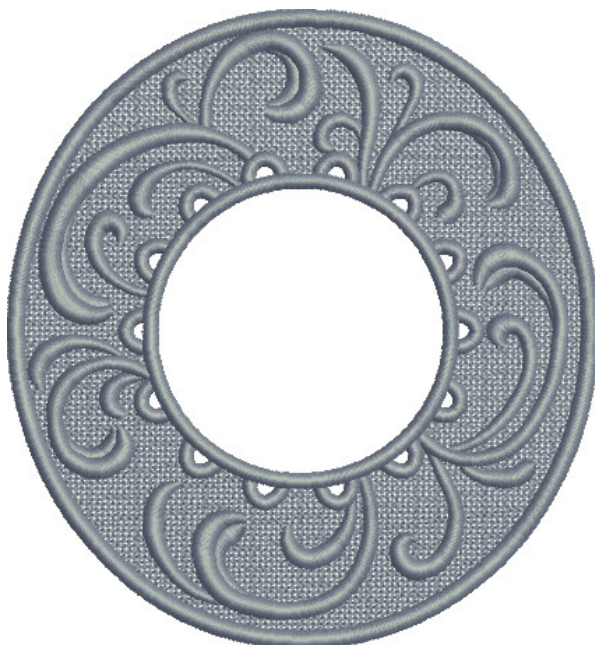

Size Inches:	Size mm:	Stitch Count:
4.42 X 4.78 in.	112.27 X 121.41 mm	34,021 St.

■ 1. Hat Brim0112

Note: Some designs in this collection may have been created using unique special stitches and/or techniques. To preserve design integrity when rescaling or rotating designs in your software, always rescale or rotate designs using the handles directly on-screen.

12599-34 Swirly Top Hat Top FSL

Size Inches:	Size mm:	Stitch Count:
2.67 X 3.13 in.	67.82 X 79.50 mm	17,336 St.

■ 1. Hat Top0112



12599-35 Left Arm Branch FSL

Size Inches:	Size mm:	Stitch Count:
4.48 X 4.82 in.	113.79 X 122.43 mm	11,196 St.

■ 1. Left Arm Branch..... 1055



Note: Some designs in this collection may have been created using unique special stitches and/or techniques. To preserve design integrity when rescaling or rotating designs in your software, always rescale or rotate designs using the handles directly on-screen.

12599-36 Right Arm Branch FSL

Size Inches:	Size mm:	Stitch Count:
4.48 X 4.82 in.	113.79 X 122.43 mm	11,196 St.

■ 1. Right Arm Branch	1055
-----------------------------	------



Stabilizer

- OESD BadgeMaster
- OESD StabilStick CutAway stabilizer
- OESD AquaMesh Plus (precut applique method)
- OESD AquaMesh (cut in place applique method)
- OESD Perfect Embroidery Tape WashAway (cut in place applique method) optional

Notions

- Isacord threads as per thread chart and fabric selection
- OESD Alligator Clamps
- OESD Button Clips
- OESD Perfect Embroidery Press Cloth (optional)
- 505 Temporary Spray Adhesive (optional)
- 1½ yard ribbon, yarn or twine (for hat)
- Upholstery needle

Fabrics

- 1/4 yard fabric for applique pieces

SUMMARY



Chevron Snowman

- Requires 6 Chevron Snowman Bottom Sections FSA – 12599-01
- Requires 1 Chevron Snowman Middle Back Section FSA – 12599-02
- Requires 1 Chevron Snowman Middle Left Section FSA – 12599-03
- Requires 1 Chevron Snowman Middle Right Section FSA – 12599-04
- Requires 1 Snowman Head Left Section w/ Carrot FSA – 12599-05
- Requires 1 Snowman Head Right Section FSA – 12599-06
- Requires 1 Snowman Base FSA – 12599-07
- Requires 1 Blank Top Hat Sides FSL – 12599-08
- Requires 1 Blank Top Hat Brim FSL – 12599-09
- Requires 1 Blank Top Hat Top FSL – 12599-10
- Requires 1 Left Arm Branch FSL – 12599-11
- Requires 1 Right Arm Branch FSL – 12599-12



Snowflake Snowman

- Requires 6 Snowflake Snowman Bottom Sections FSA – 12599-13
- Requires 1 Snowflake Snowman Middle Back Section FSA – 12599-14
- Requires 1 Snowflake Snowman Middle Left Section FSA – 12599-15
- Requires 1 Snowflake Snowman Middle Right Section FSA – 12599-16
- Requires 1 Snowman Head Left Section w/ Carrot FSA – 12599-17
- Requires 1 Snowman Head Right Section – 12599-18
- Requires 1 Snowman Base FSA – 12599-19
- Requires 1 Swirly Top Hat Sides FSL – 12599-20
- Requires 1 Swirly Top Hat Brim FSL – 12599-21
- Requires 1 Swirly Top Hat Top FSL – 12599-22
- Requires 1 Left Arm Branch FSL – 12599-23
- Requires 1 Right Arm Branch FSL – 12599-24



Blank Snowman

- Requires 6 Blank Snowman Bottom Sections FSA – 12599-25
- Requires 1 Blank Snowman Middle Back Section FSA – 12599-26
- Requires 1 Blank Snowman Middle Left Section FSA – 12599-27
- Requires 1 Blank Snowman Middle Right Section FSA – 12599-28
- Requires 1 Snowman Head Left Section w/ Carrot FSA – 12599-29
- Requires 1 Snowman Head Right Section FSA – 12599-30
- Requires 1 Snowman Base FSA – 12599-31
- Requires 1 Swirly Top Hat Sides FSL – 12599-32
- Requires 1 Swirly Top Hat Brim FSL – 12599-33
- Requires 1 Swirly Top Hat Top FSL – 12599-34
- Requires 1 Left Arm Branch FSL – 12599-35
- Requires 1 Right Arm Branch FSL – 12599-36



PRECUT APPLIQUE



STEP 1 Prep Applique Fabric

- Apply StabilStick CutAway to the back of the applique fabric by removing the paper to expose the adhesive surface.
- **To continue, select either the Precut Applique Method or the Cut in Place Applique Method.**

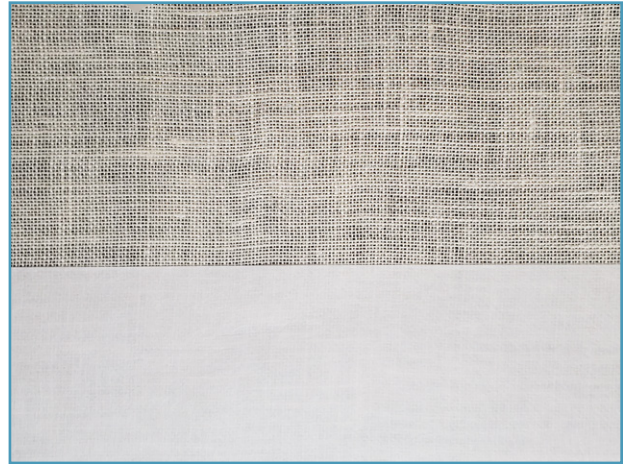

STEP 2 Precut Applique Method

- Print Applique Templates.
- Cut pieces of StabilStick CutAway 8.5" x 11". Print templates of the required design pieces on the paper side of the cut StabilStick CutAway stabilizer. (See chart below for design number and quantity required.)

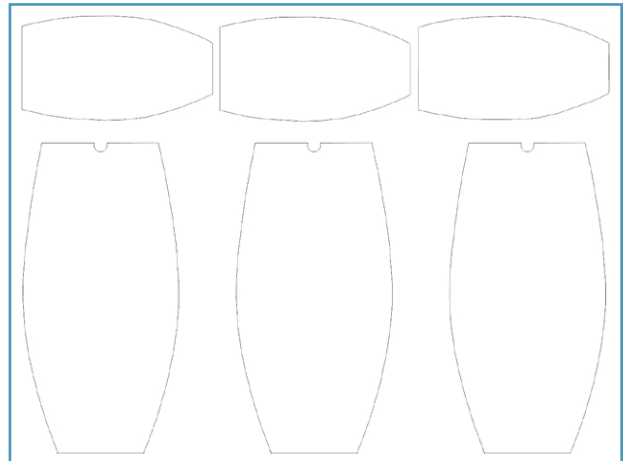

STEP 3 Apply Templates to Fabric

- Roughly cut out the StabilStick CutAway templates 1/8"-1/4" around the design. Remove the paper backing. Stick the template on the wrong side of the prepared applique fabric.

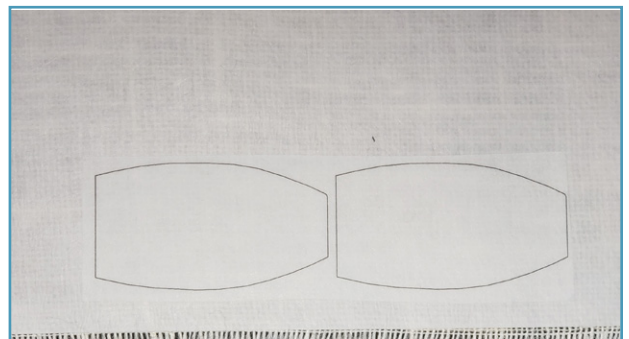

PRECUT APPLIQUE



STEP 4 Cut out template

- Cut out the applique on the outside edge of printed line. Set aside.

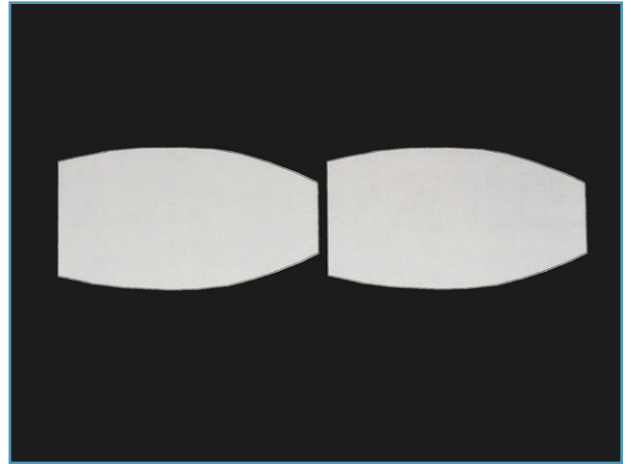

STEP 5 Hoop AquaMesh Plus

- Hoop AquaMesh Plus paper side up. Score the paper and peel it away to reveal the sticky surface.



STEP 6 Stitch placement line

- Stitch the placement stitch for the design.
- **Tip - the placement stitch is the first stitch of the design for every applique design.**
- **Note - Darker thread used in image to improve visibility.**



PRECUT APPLIQUE



STEP 7 Apply the applique

- Position the prepared applique on the placement line to stitch.



STEP 8 Apply topper

- Cut a piece of BadgeMaster slightly larger than the design. Position over the design area and finger press to secure.



STEP 9 Stitch

- Stitch the remaining machine steps of the design.



PRECUT APPLIQUE



STEP 10 Finish

- Remove from hoop.
- Trim away excess stabilizers 1/4" - 1/2" around the design.
- Repeat Steps 5 - 10 for each of the applique pieces. Continue with Step 12 when complete.

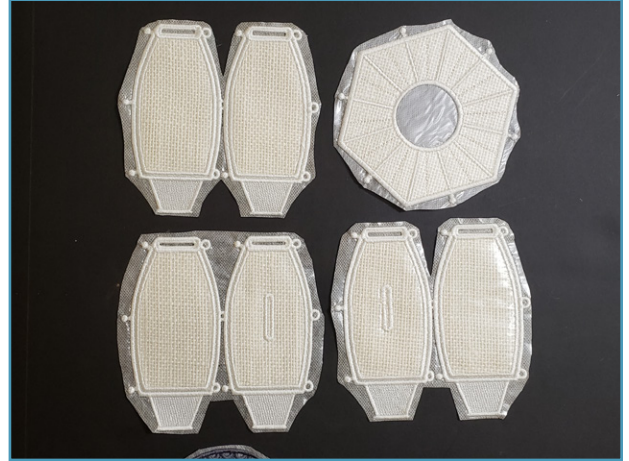

CUT IN PLACE APPLIQUE



STEP 1 Prep Applique Fabric

- Apply StabilStick CutAway to the back of the applique fabric by removing the paper to expose the adhesive surface.

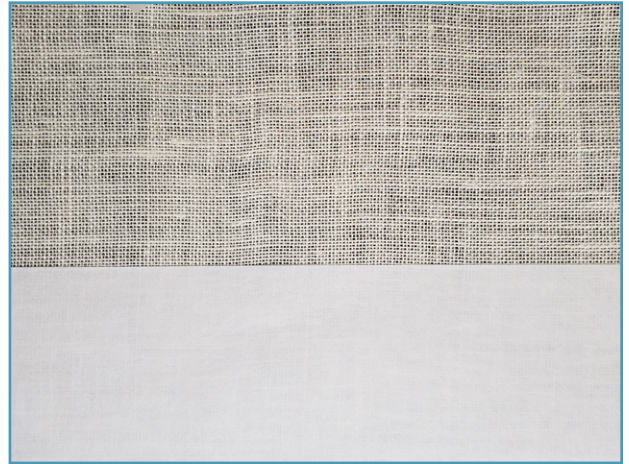

STEP 2 Apply StabilStick CutAway

- Apply a second layer of StabilStick CutAway to the back of the applique fabric as done in Step 1.



STEP 3 Hoop AquaMesh Stabilizer

- Hoop 2 layers of AquaMesh stabilizer.



CUT IN PLACE APPLIQUE



STEP 4 → Stitch placement line

- Stitch the placement stitch for the design.
- **Tip - the placement stitch is the first stitch of the design for every applique design in this collection.**
- **Note - Darker thread used in image to improve visibility.**

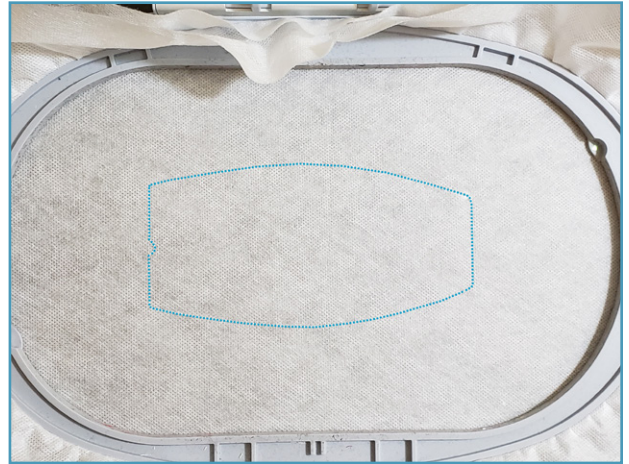

STEP 5 → Cut applique

- Cut a piece of applique fabric slightly larger than the design area.
- Position the prepared applique fabric right side up completely covering the placement line stitch.

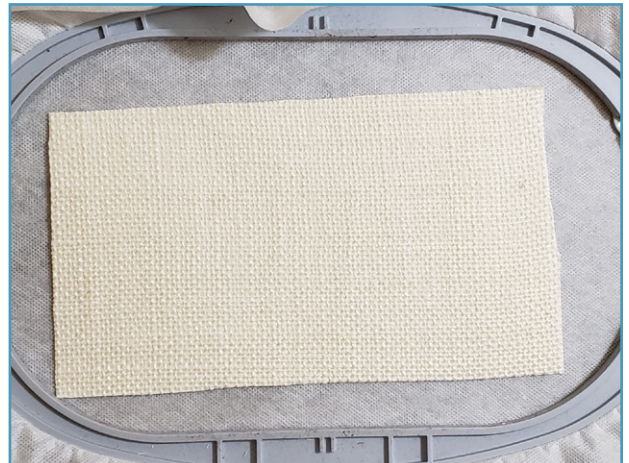

STEP 6 → Place applique

- Secure in place with Expert Embroidery Tape WashAway or spray the back with 505 Temporary Spray Adhesive.

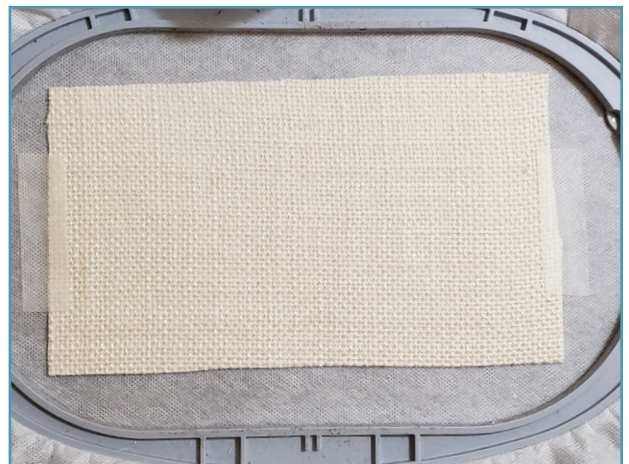

CUT IN PLACE APPLIQUE



STEP 7 → Stitch tackdown

- Stitch the Cut Line & Tackdown stitch.

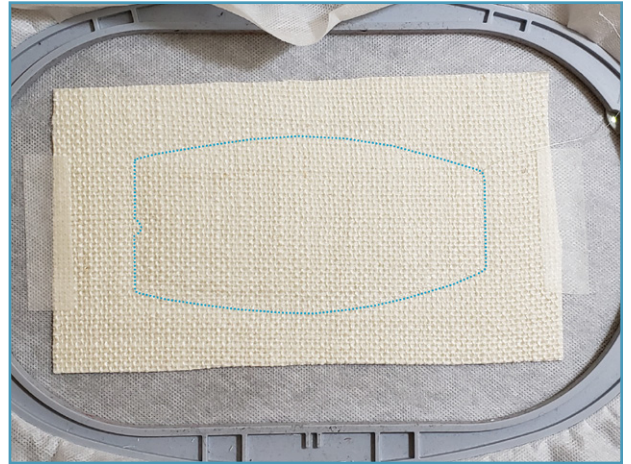

STEP 8 → Trim applique

- Remove the hoop from the machine without disturbing the project in the hoop.
- Carefully trim away the excess applique fabric close to the tackdown line.



STEP 9 → Apply topper

- Cut a piece of BadgeMaster slightly larger than the design. Position over the design area. Secure with Expert Embroidery Tape WashAway, or 505 Temporary Spray Adhesive.

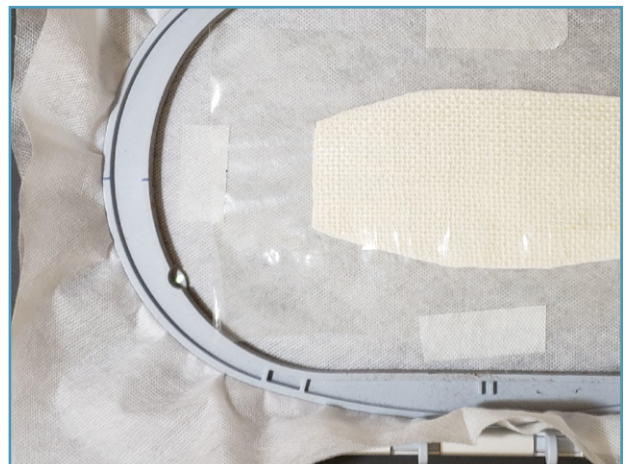

CUT IN PLACE APPLIQUE



STEP 10 Finish

- Complete the design stitching, changing thread colors as required.
- Remove from hoop.
- Trim away excess stabilizers 1/4" - 1/2" around the design.
- Repeat Steps 4 - 10 for each of the applique pieces.

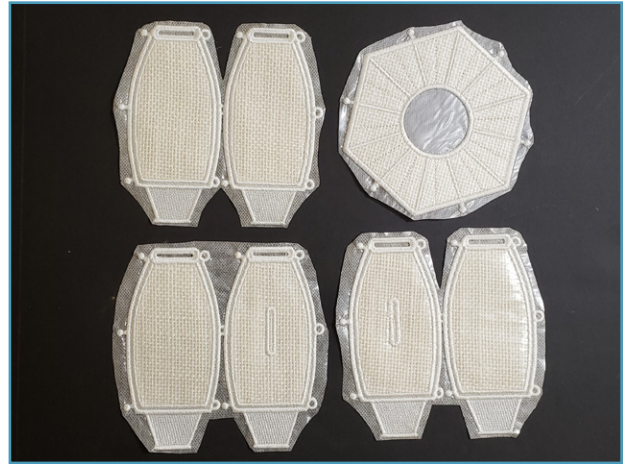

STEP 11 Stitch remaining pieces

- Hoop a layer of AquaMesh with a layer of BadgeMaster and follow the color chart to stitch the remaining (non-applique) snowman arms and hat pieces.
- Remove from hoop and carefully trim away excess stabilizers to 1/4"-1/2" from outer design edge.

STEP 12 Rinse away stabilizer

- Using warm running water, rinse each design piece to remove wash away stabilizers.
- Roll the carrot and secure with a pin to dry.
- Lay remaining pieces flat to dry.
- When dry, place right side down on OESD Perfect Embroidery Press Cloth and press with steam to remove all wrinkles. Let cool.

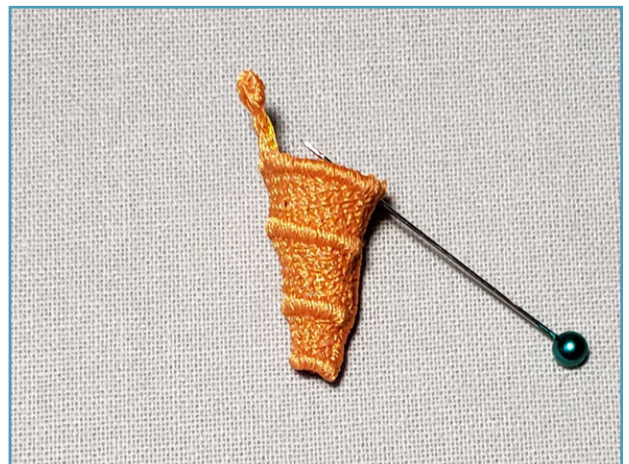

ASSEMBLY



STEP 1 Bottom section

- Assemble the bottom section of the snowman by pulling the five buttonettes of one section through the five eyelets of the next section with Alligator Clamps. Repeat for all six sections.
- Use Button Clips to hold buttonettes in place during assembly.
- **Note - buttonettes may be pulled through to the inside or the outside as desired.**



STEP 2 Base

- Pull the buttonettes on the snowman base through the eyelets in each of the six sections as shown.

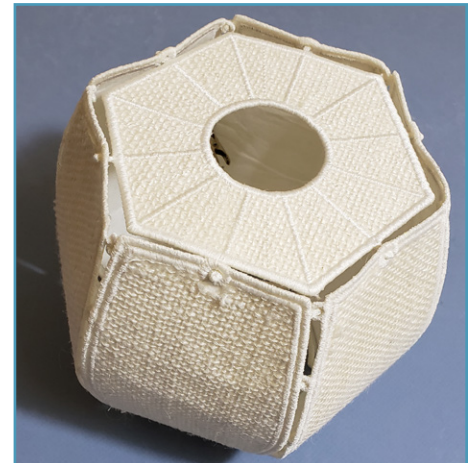

STEP 3 Center section

- Carefully slice open the slits for the arms
- Connect the buttonettes on each of the three paired sections. Connect the three sections together so that the slits for the arm branches are opposite of each other.



ASSEMBLY



STEP 4 Head section

- The head section is divided into two sections of three pieces. Connect the two sections together. Then, connect the remaining sections. Use Button Clips as needed.
- Note - the section where the two eyes meet have two eyelets for the nose placement.

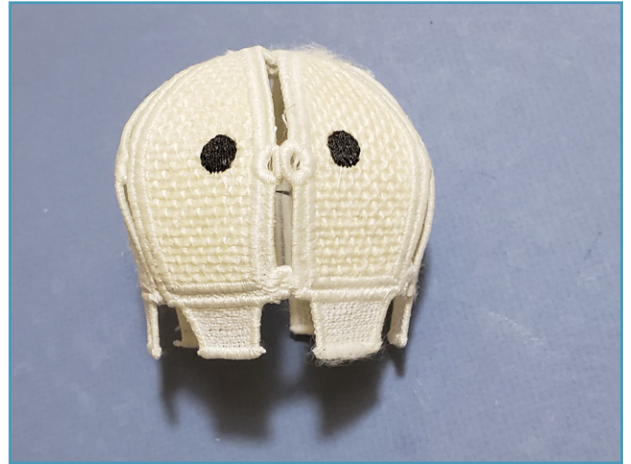

STEP 5 Nose

- Attach the nose to head through the two eyelets below the eyes.



STEP 6 Connect head to center body

- Connect the head to the center body by inserting the flaps through the top openings in the center body.
- Attach the stick arms to the center body.



ASSEMBLY



STEP 7 Connect the base

- Connect the head and torso to the base by fitting the torso flaps through the snowman base.



HAT ASSEMBLY



STEP 1

- For further assistance, see the diagram below,
- Stitch all four pieces of the top hat.



Begin at *A, start under brim and overlap holes on sides
Stitch up to B, then halfway around the top of hat to C
Stitch down to D, overlapping the holes on sides
Stitch the brim to the sides from D all the way back around to D
Stitch back up to C, overlapping holes on sides
Stitch the other half of the top of hat back around to B
Stitch back down to A overlapping sides to end ●

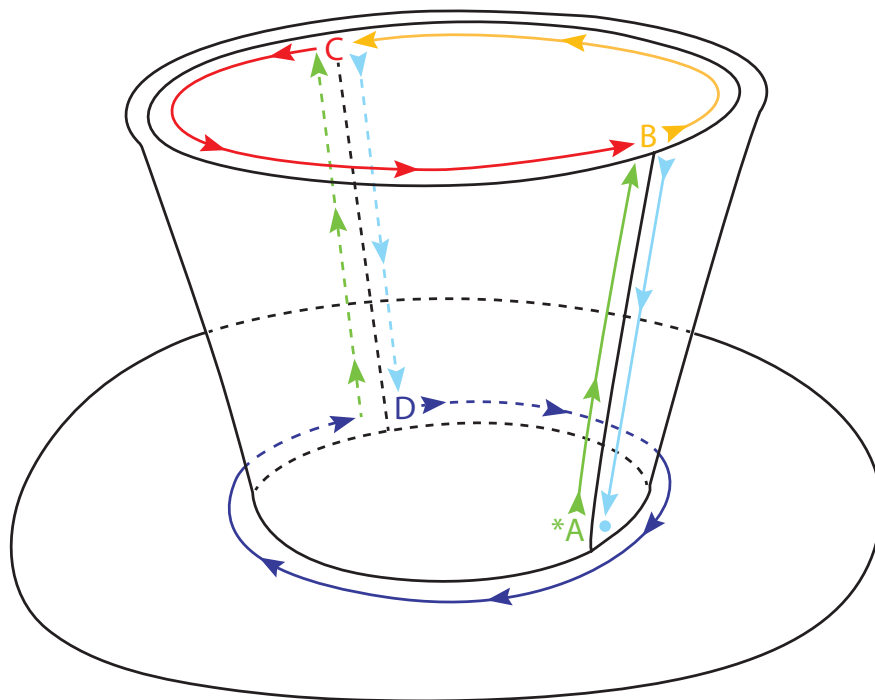

HAT ASSEMBLY



STEP 2

- Thread an upholstery needle with 1.5 yards of yarn, ribbon, or twine. Leaving a 3"-4" tail, bring the yarn up through a hole in the middle of the brim. Make a knot or secure with a Button Clip to hold the end of the yarn in place.



STEP 3

- Overlap two bands (sides) of the hat at the holes. The smaller curves are the bottom and connect to the brim. The larger sides connect to the top. Bring the yarn through the bottom hole from the back.



STEP 4

- Continue stitching to the top edge, as shown.



HAT ASSEMBLY



STEP 5

- Bring the yarn up through one of the holes on the top piece. Continue to attach one band to the hat top.



STEP 6

- At the end of that band, align the holes with the other band and stitch down to the brim.



STEP 7

- At the brim, run the yarn down through the hole in the brim opposite of the original starting point (see Step 2).



HAT ASSEMBLY



STEP 8

- Attach the band to the brim until the opposite side is reached. Then insert the needle through the bottom hole to the inside of the hat, as shown.



STEP 9

- Return up the side of the hat through the holes as shown.



STEP 10

- Then connect the unstitched side of the hat. Finish the stitching down the opposite side of the band.



HAT ASSEMBLY



STEP 11

- Stitch the remaining band to the brim. The final stitch matches up with the loose end. Tie the ends together in a knot. Trim loose ends.



APPLIQUE PATTERNS

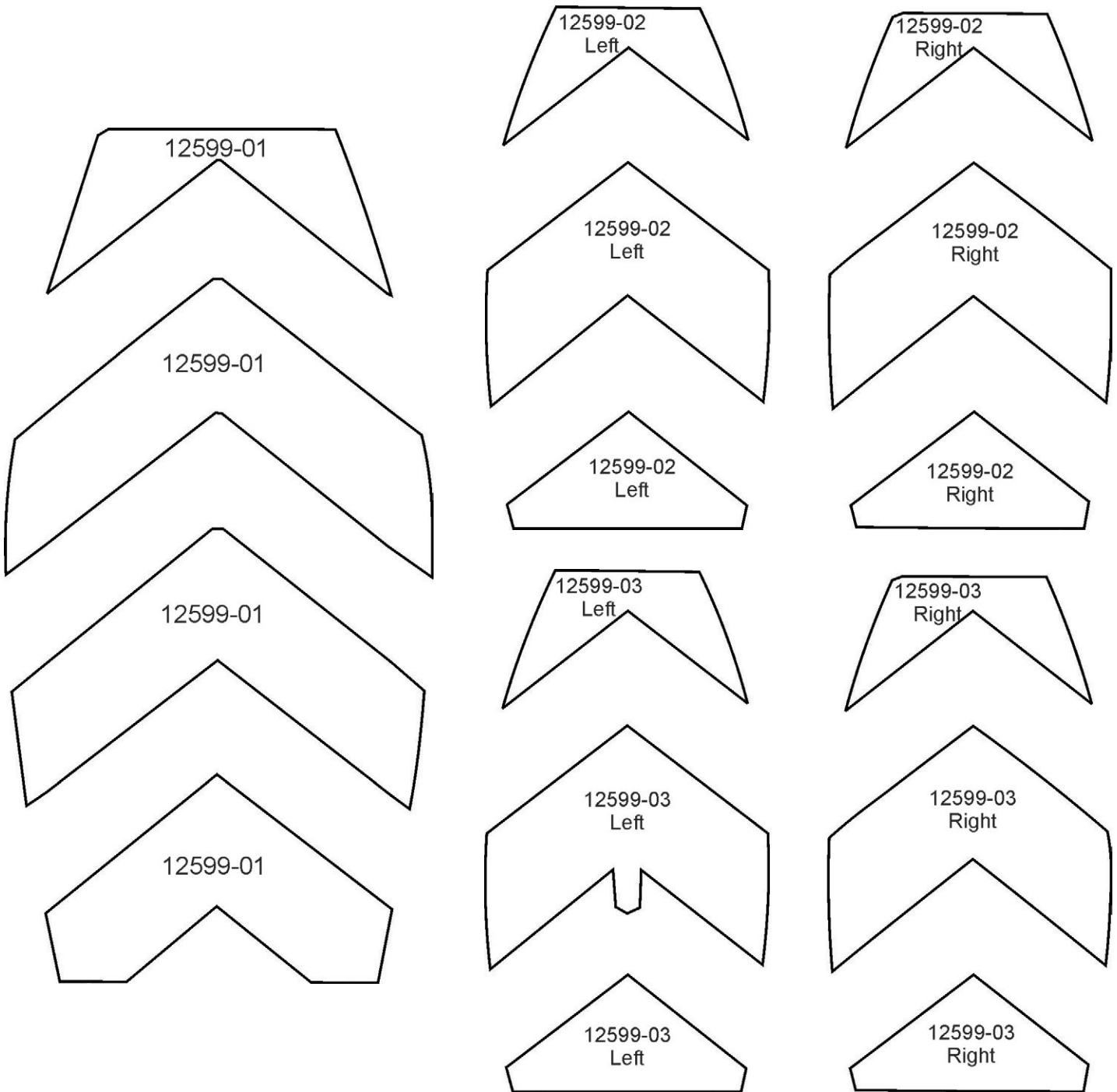

APPLIQUE PATTERNS

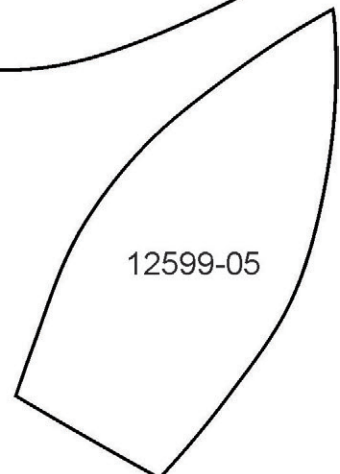
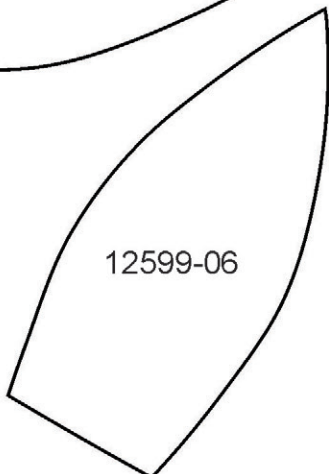
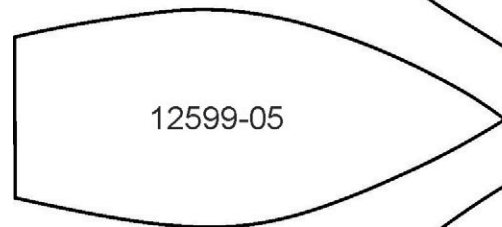
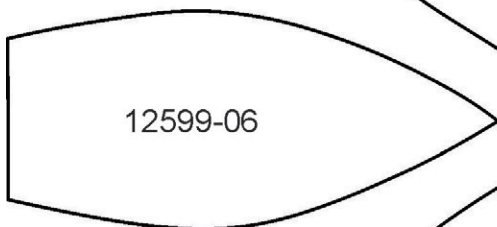
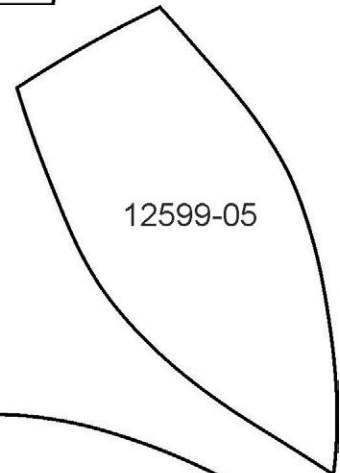
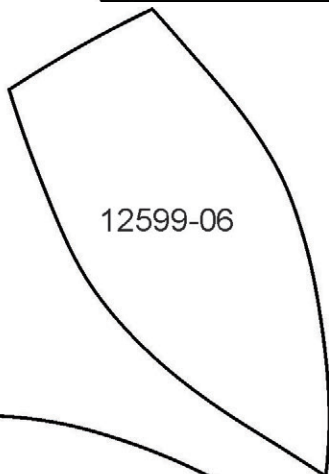
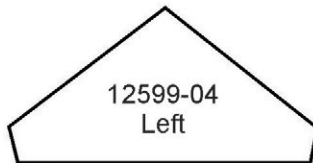
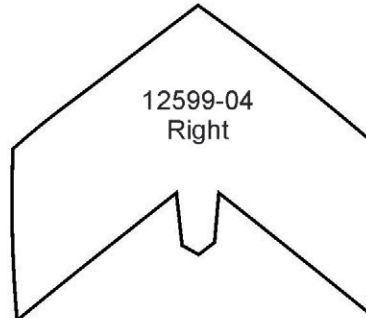
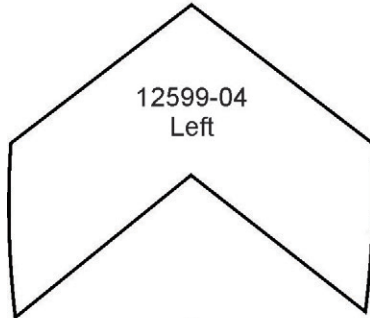
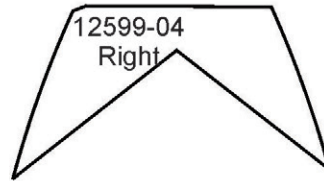
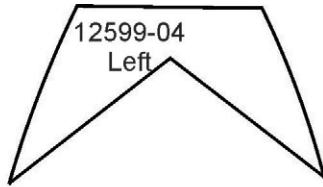

APPLIQUE PATTERNS

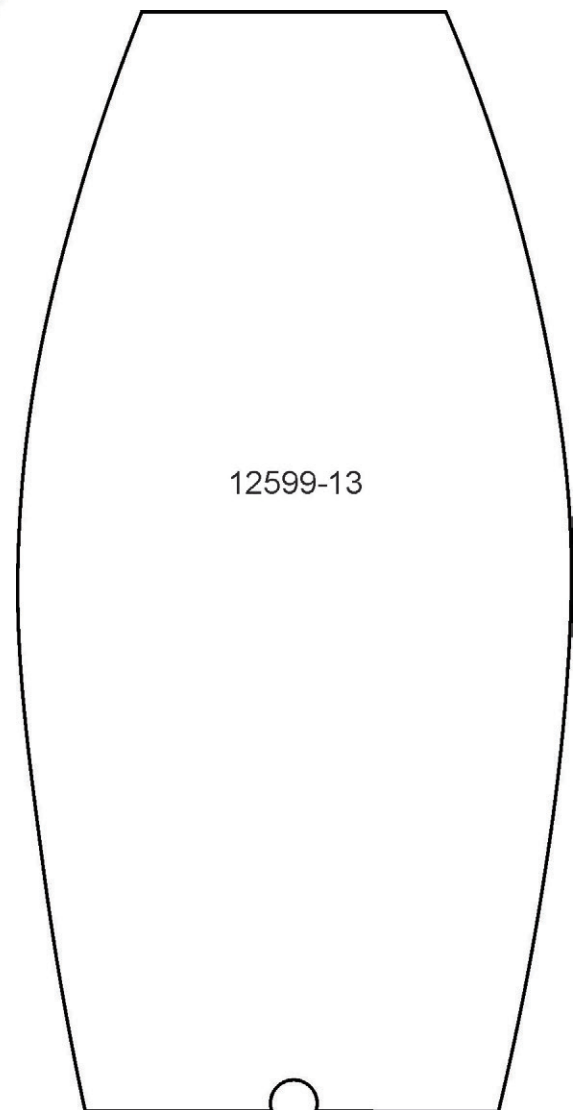
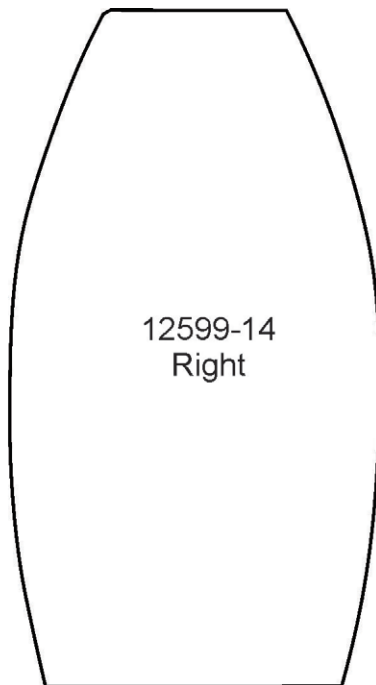
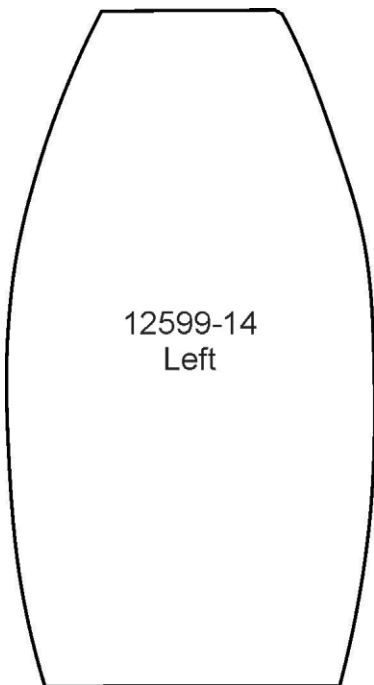
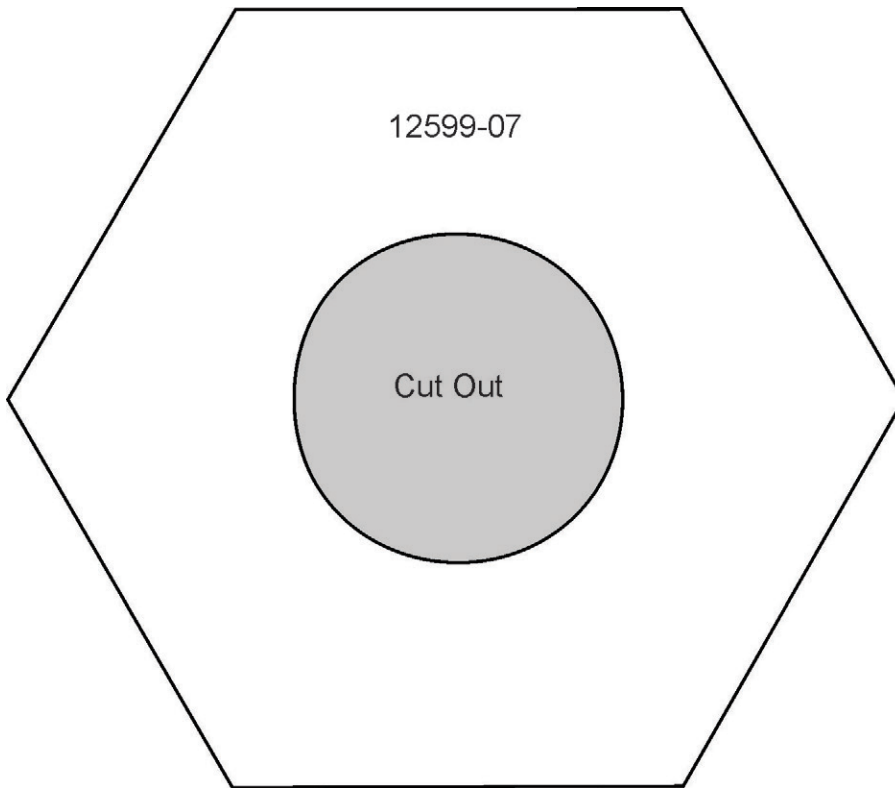

APPLIQUE PATTERNS

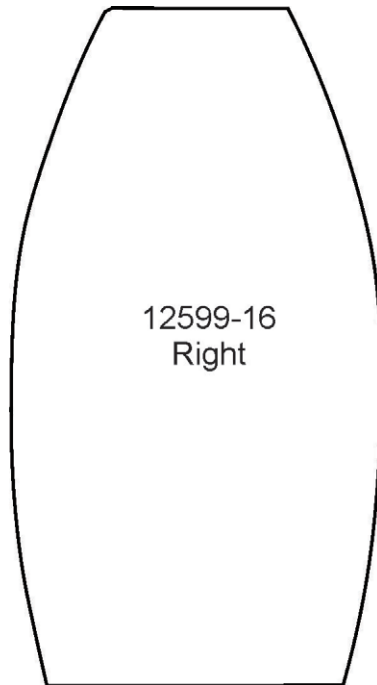
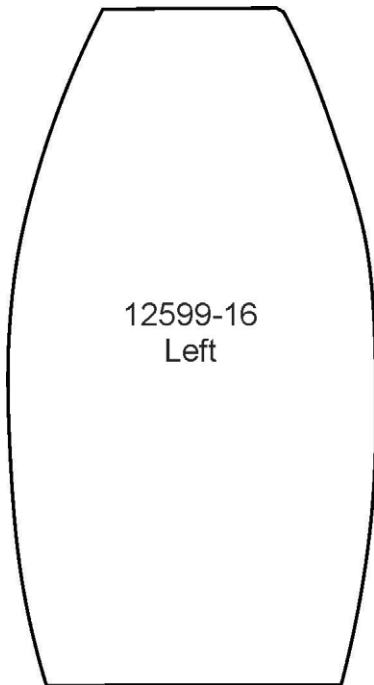
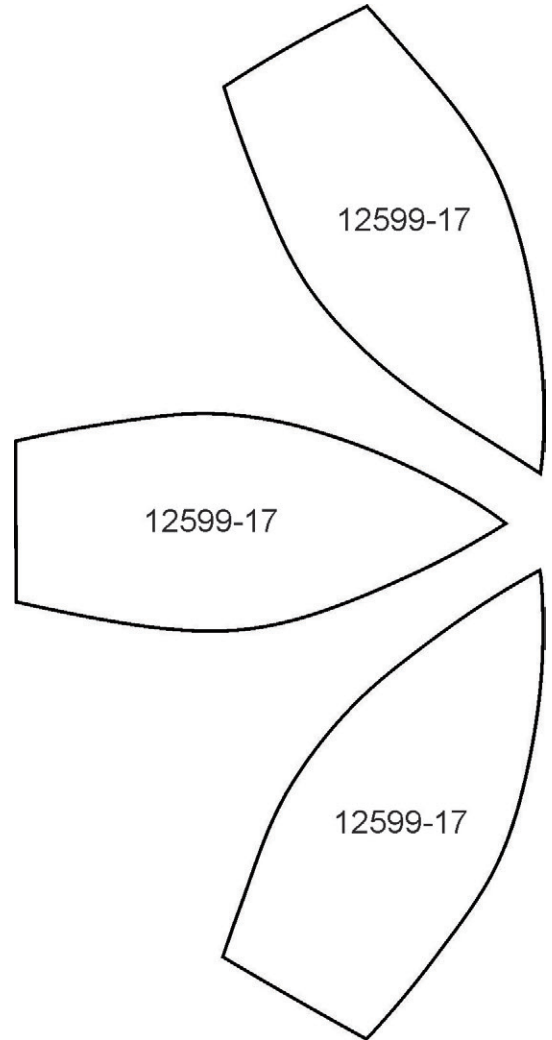
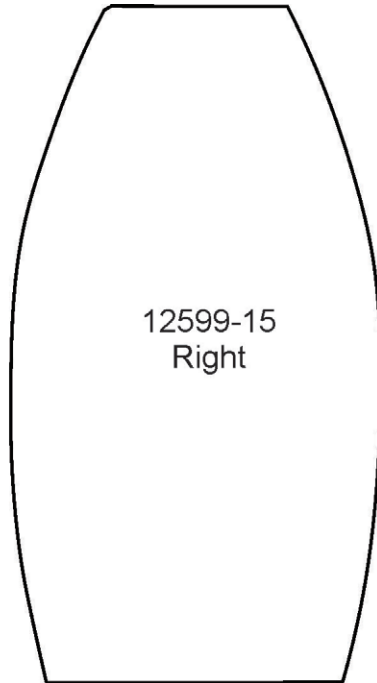
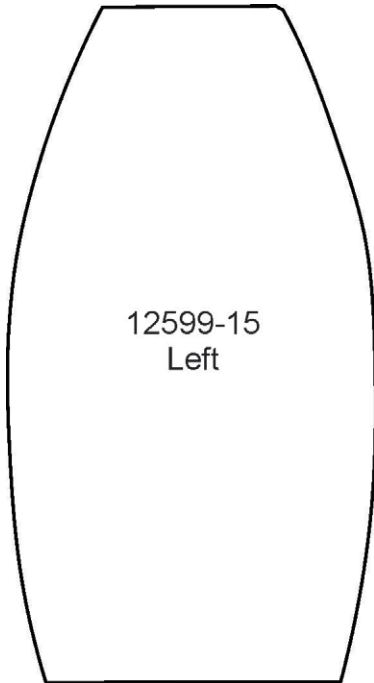

APPLIQUE PATTERNS

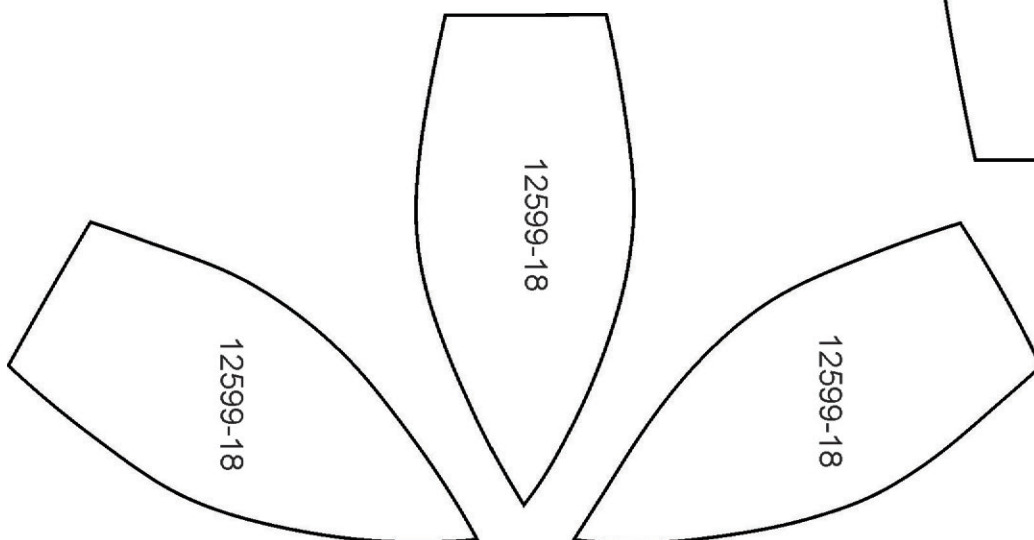
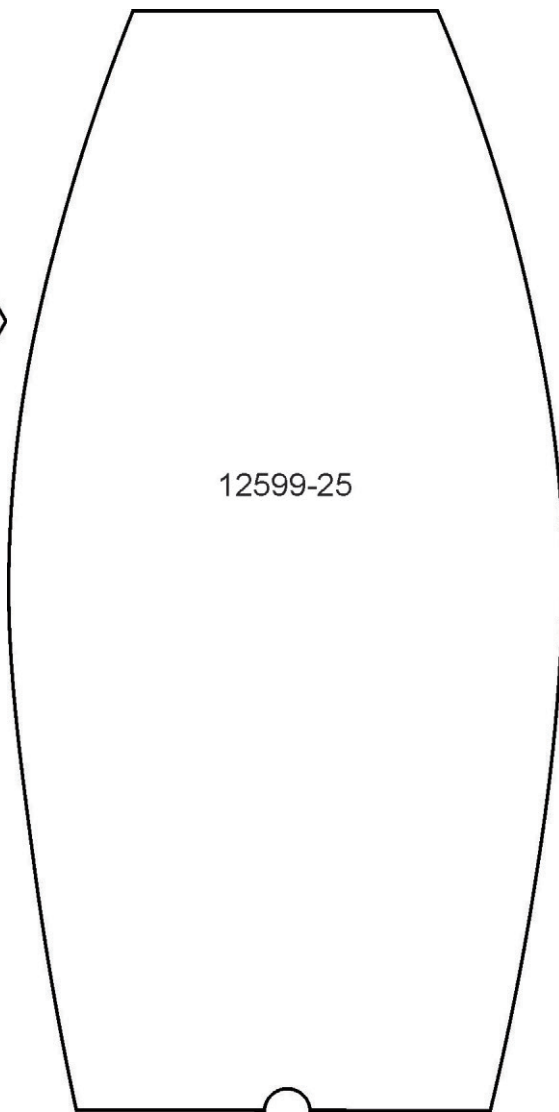
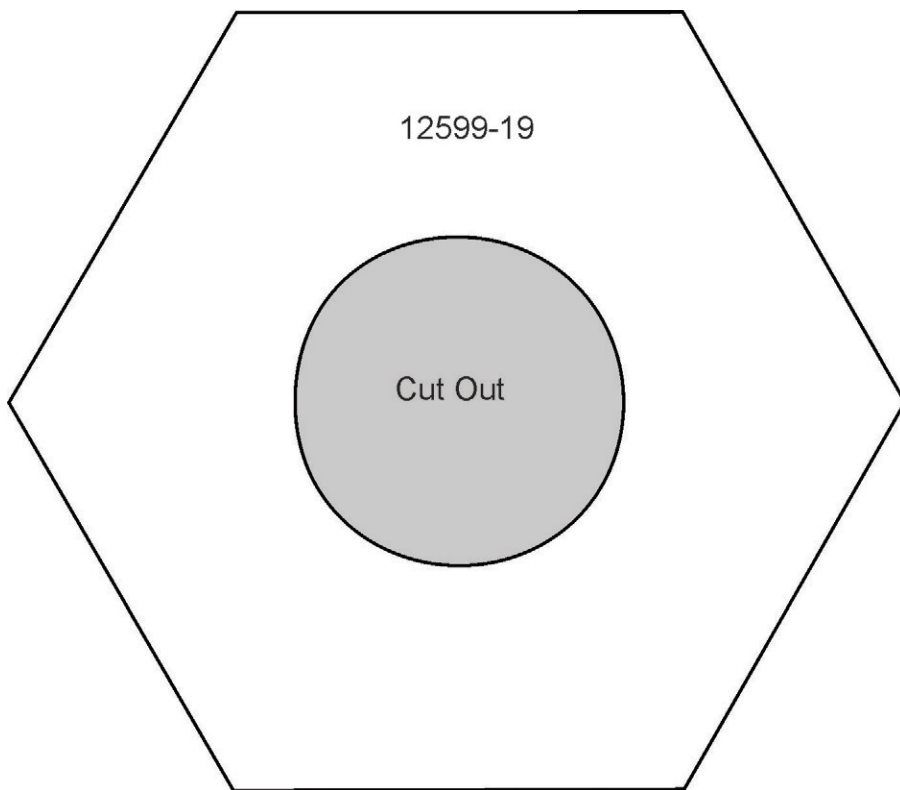

APPLIQUE PATTERNS

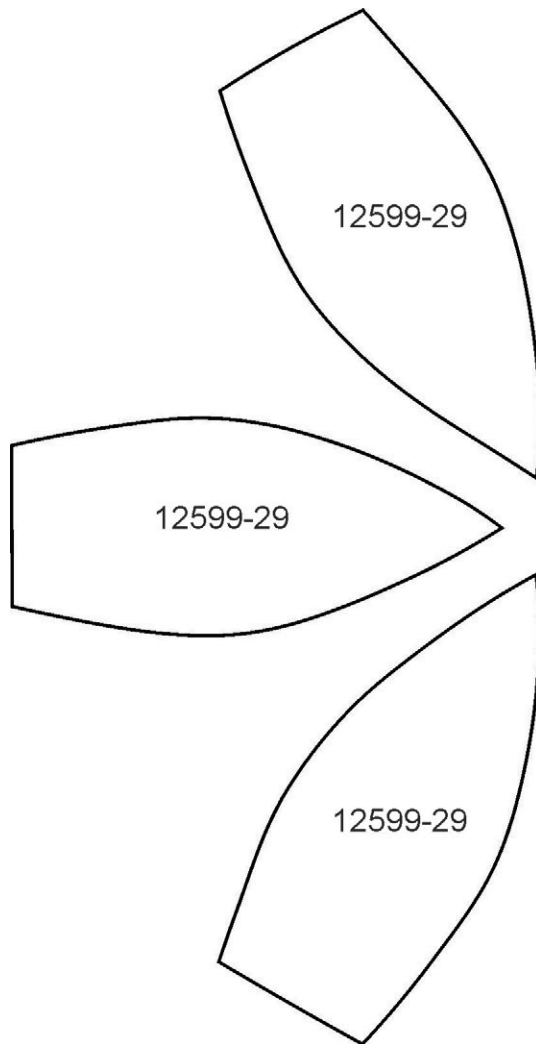
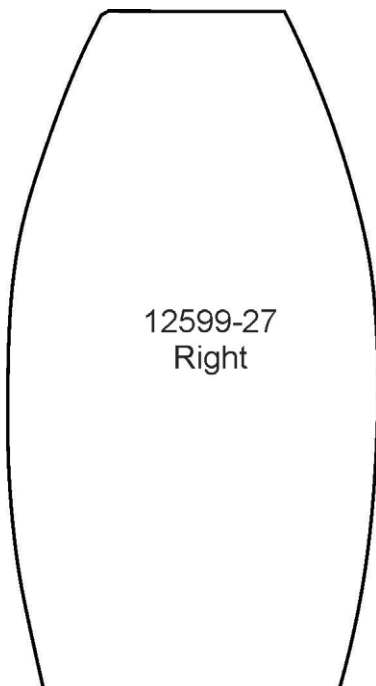
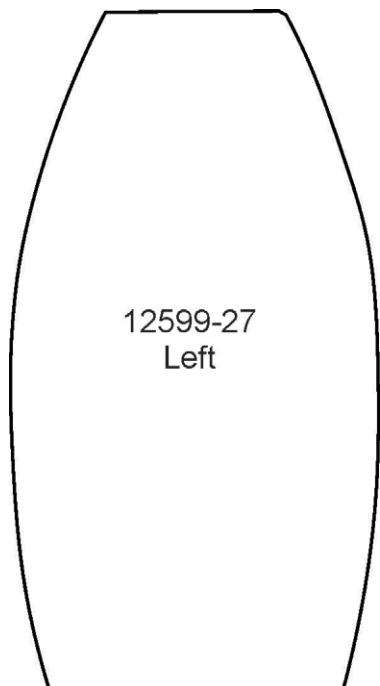
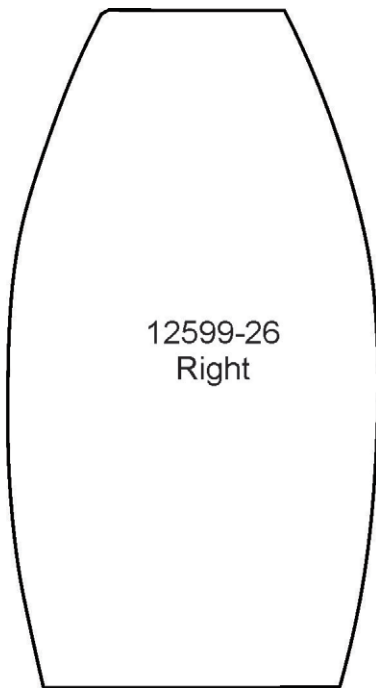
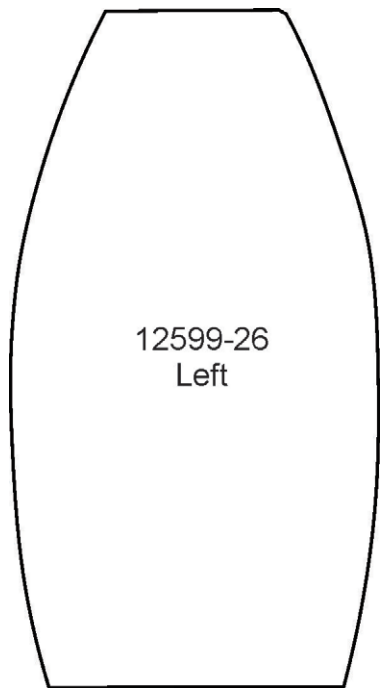

APPLIQUE PATTERNS

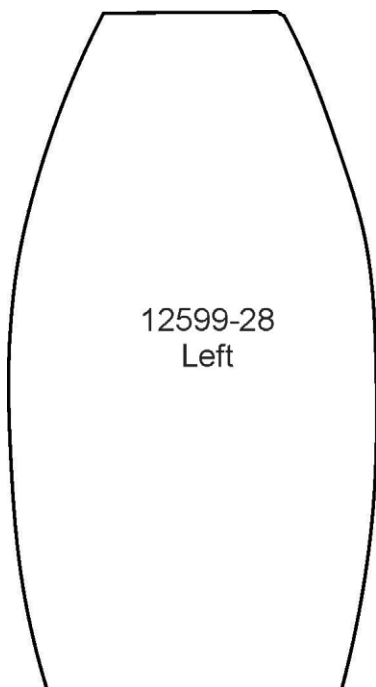

12599-28
Left

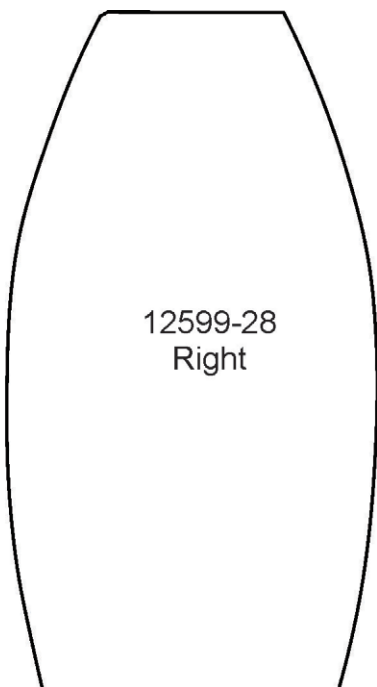

12599-28
Right

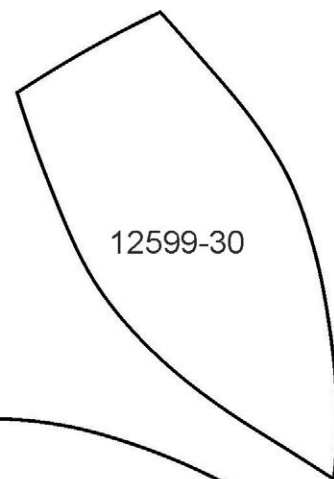

12599-30

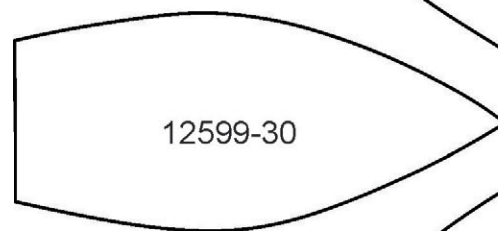

12599-30

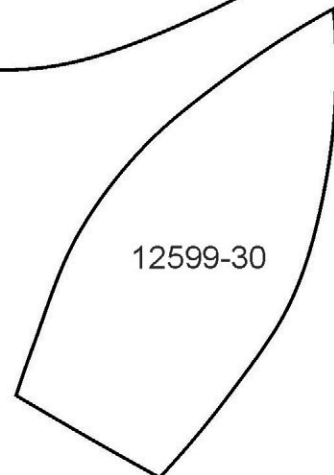

12599-30

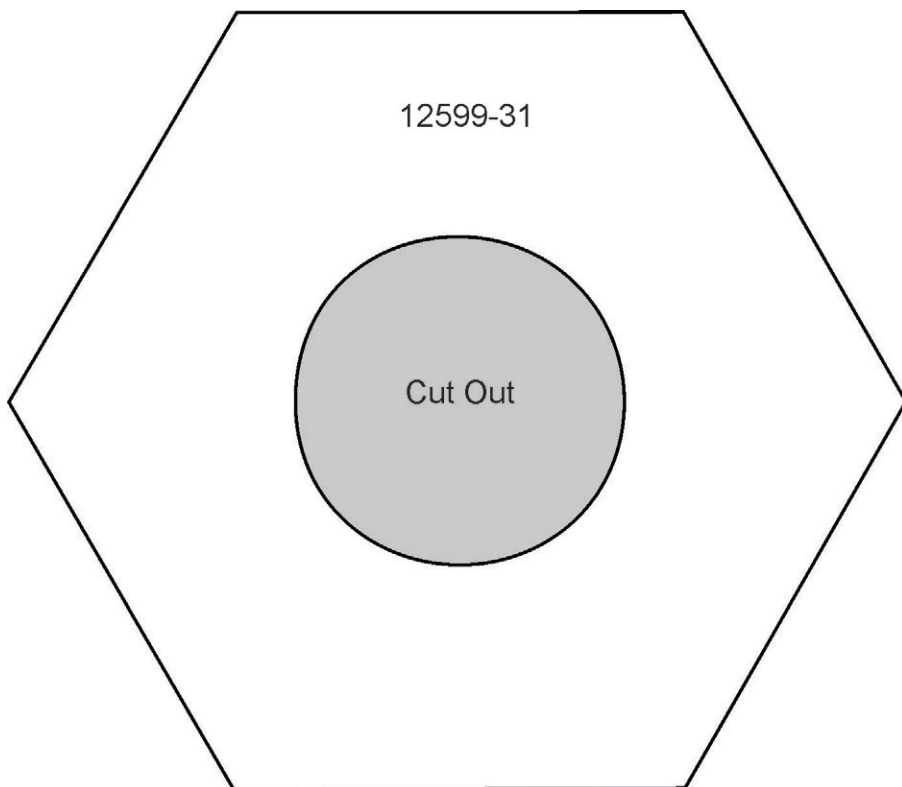

12599-31

Cut Out

MIRRORED PATTERNS

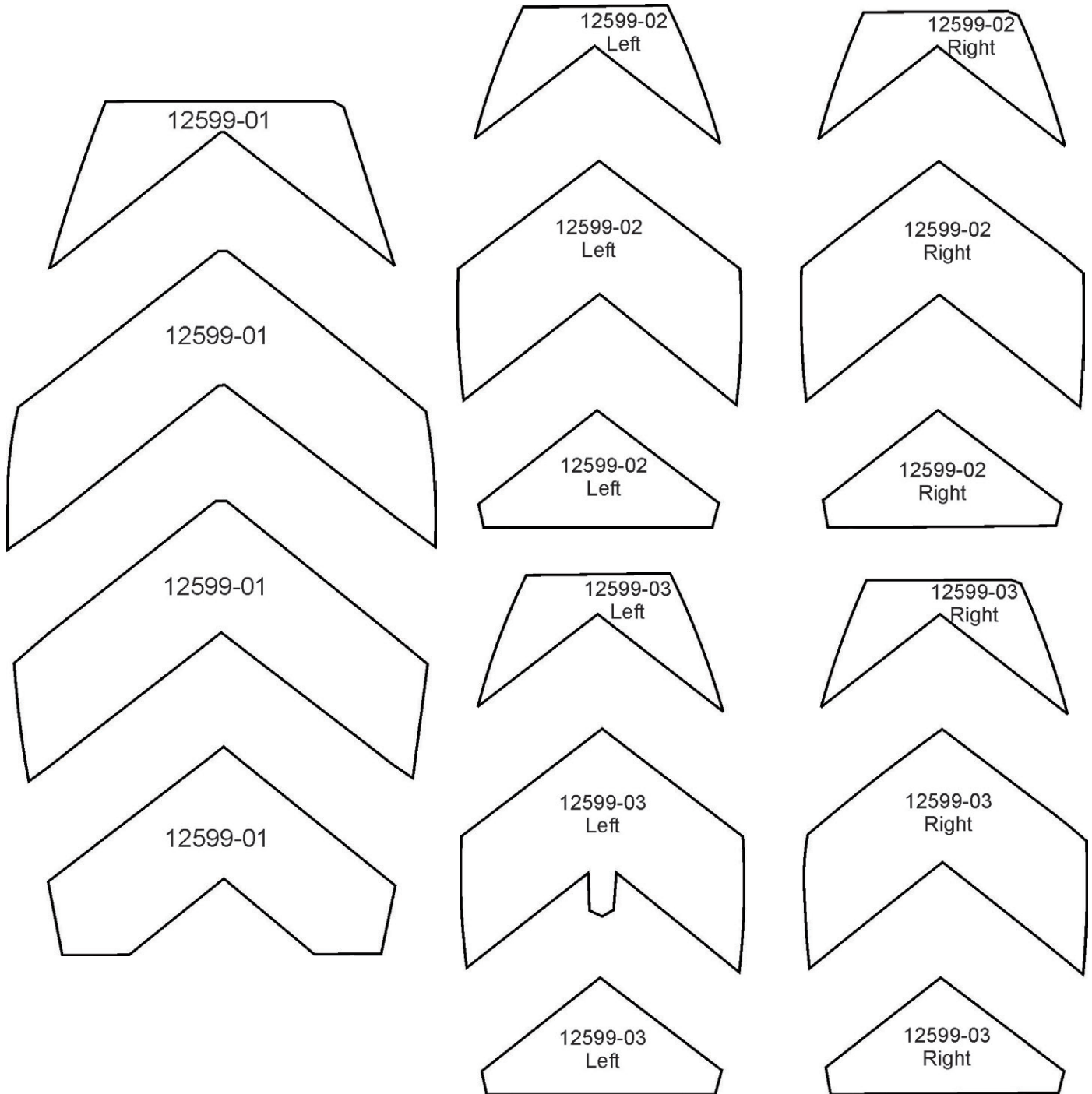

MIRRORED PATTERNS

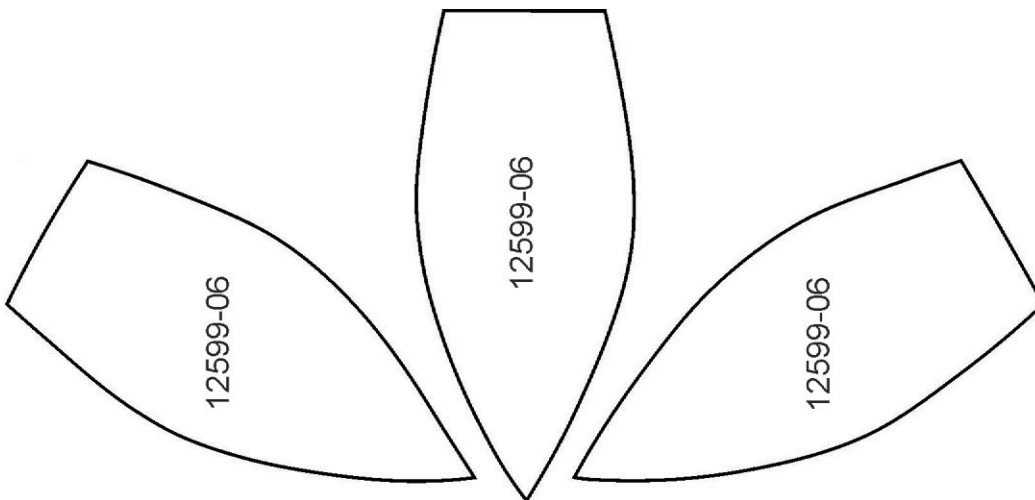
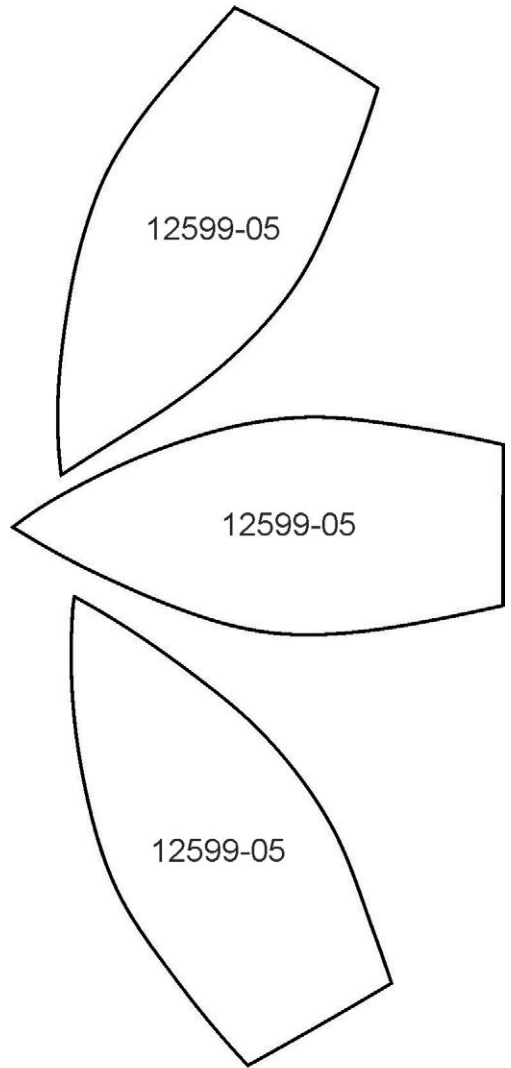
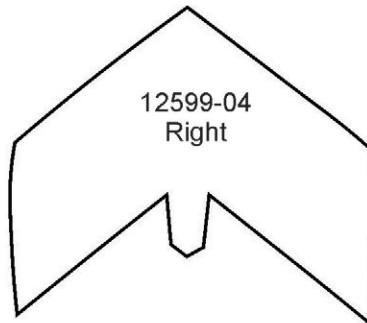
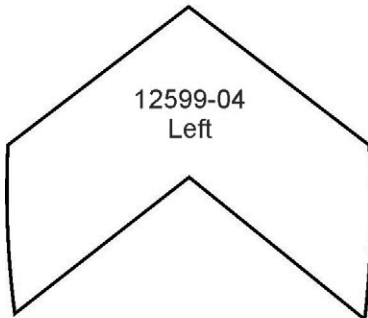
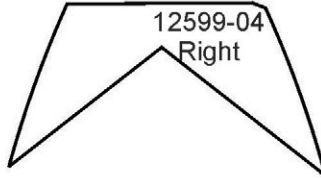
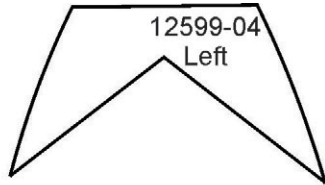

MIRRORED PATTERNS

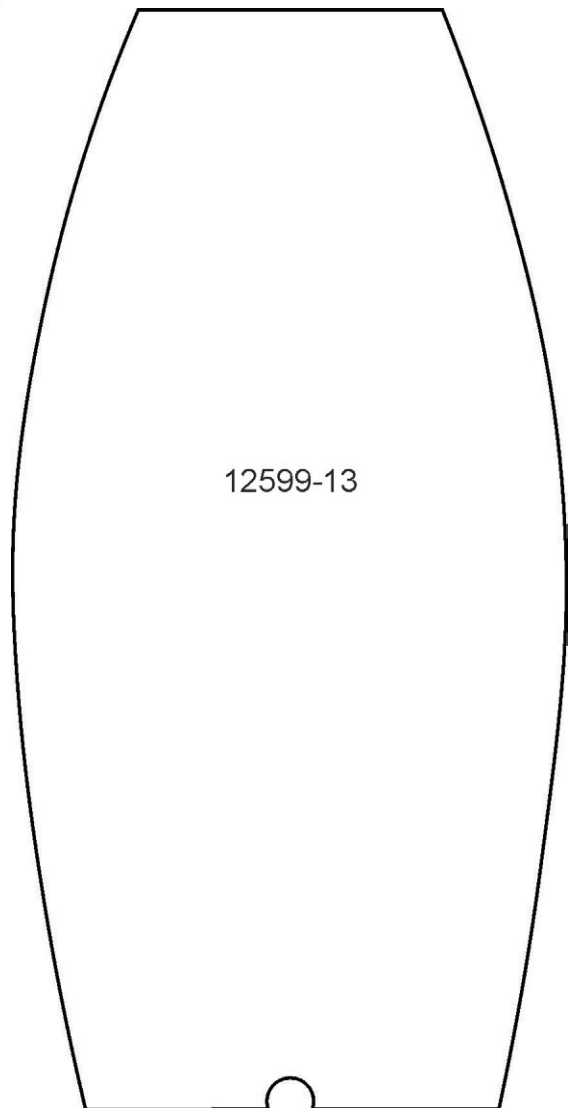
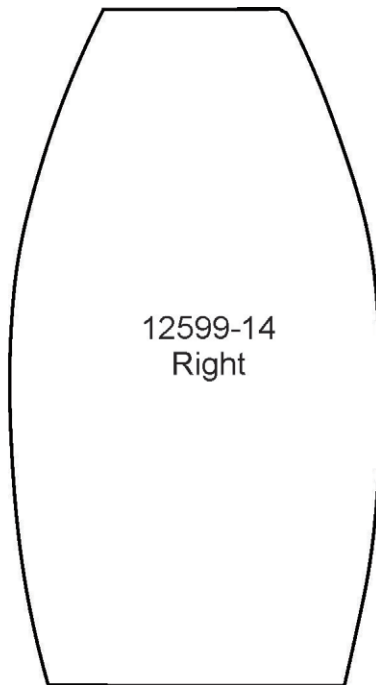
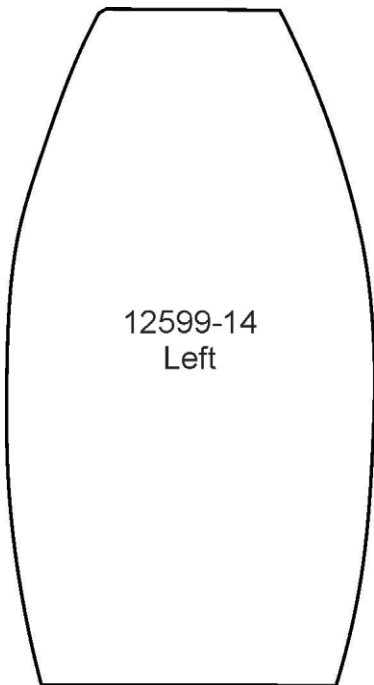
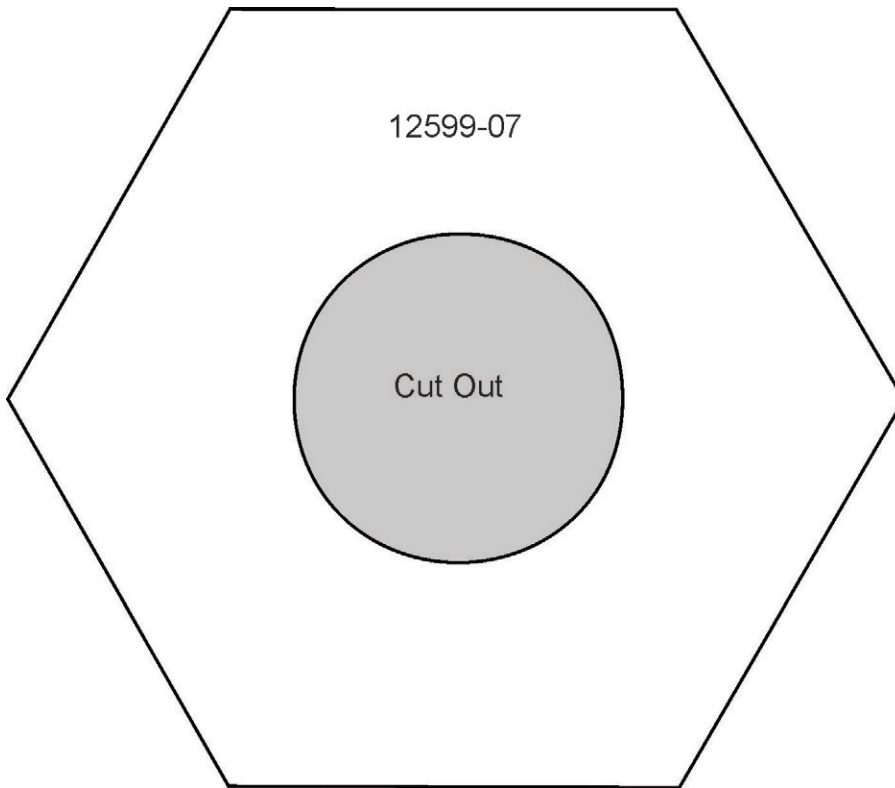

MIRRORED PATTERNS

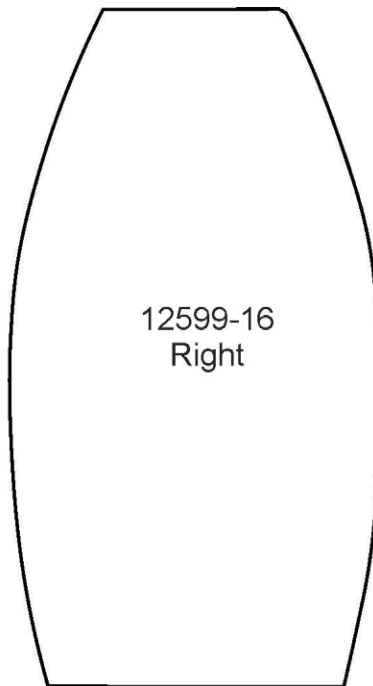
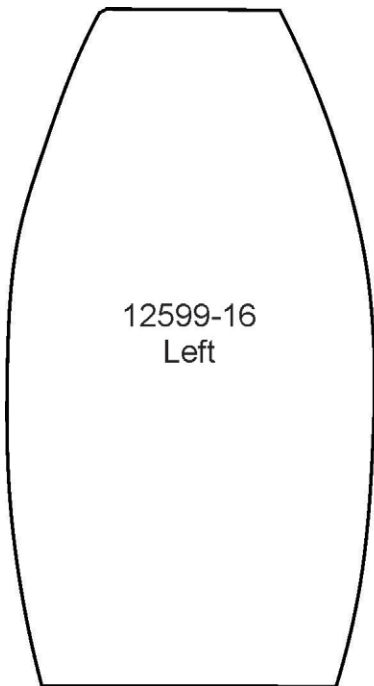
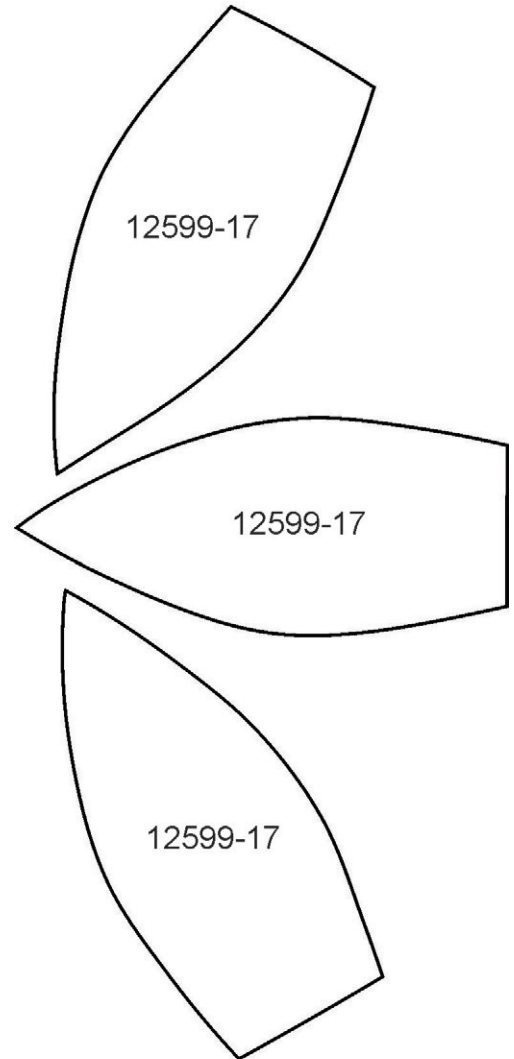
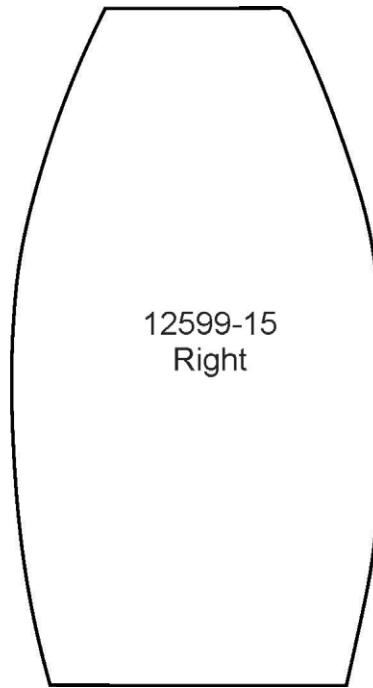
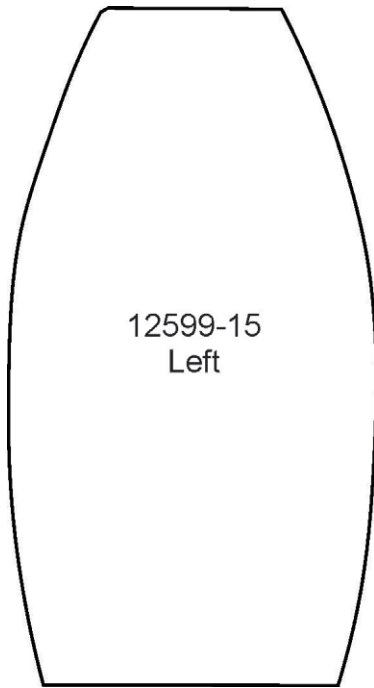

MIRRORED PATTERNS



12599-19

Cut Out

12599-25

12599-18

12599-18

12599-18

MIRRORED PATTERNS

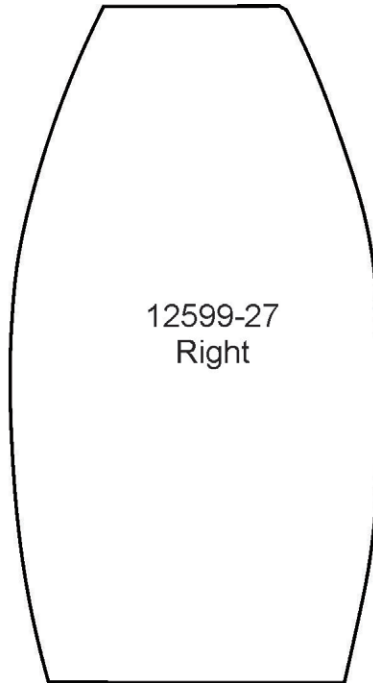
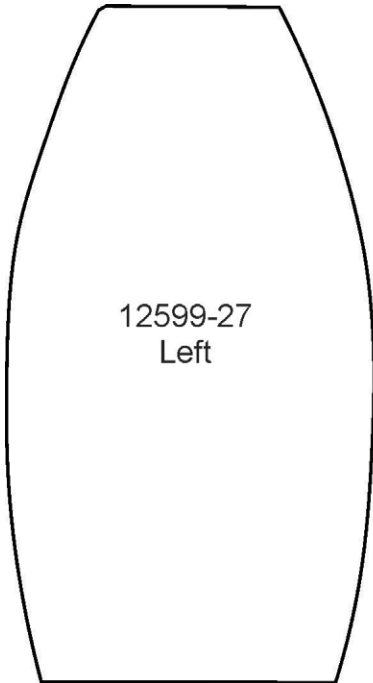
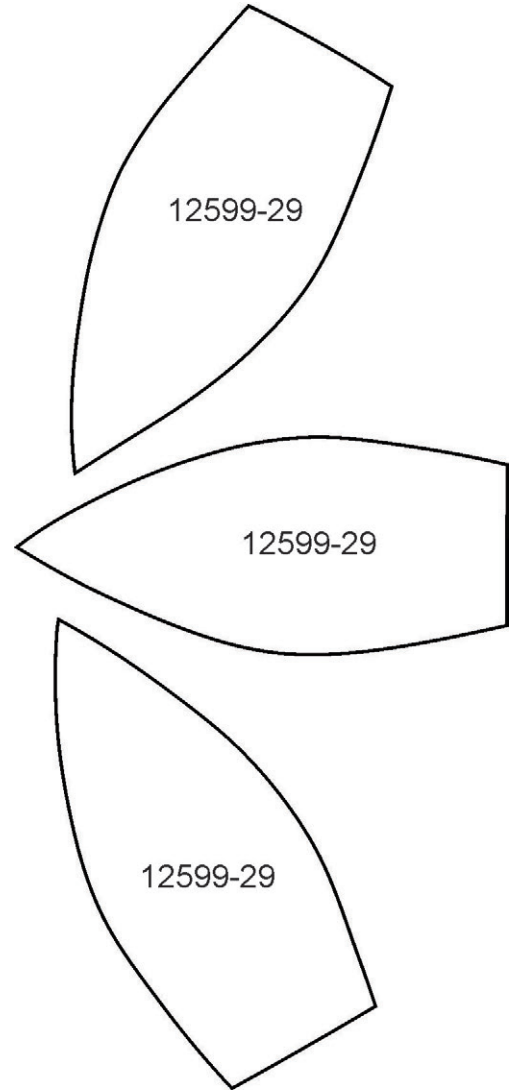
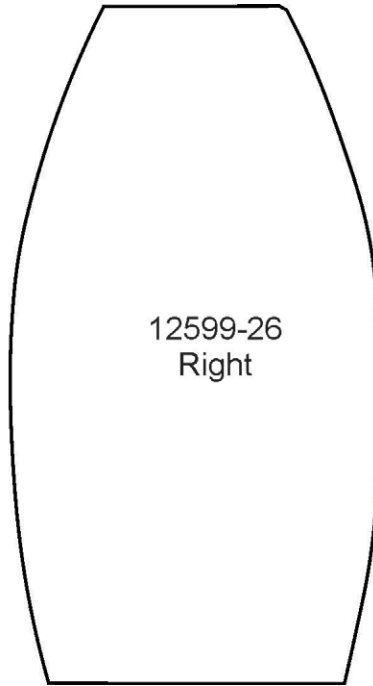
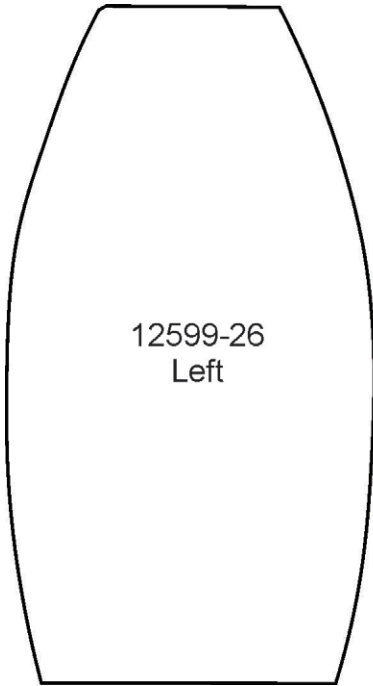

MIRRORED PATTERNS

