

FREESTANDING DRESDEN TURKEY



1

Design

Fits hoop sizes 6" x 10" and larger

THREAD LIST



Isacord Thread Colors

0015 White	1220 Apricot
0721 Antique	1311 Date
0731 Applesauce	1366 Mahogany
1032 Bronze	1921 Blossom
1055 Bark	

*** Project instructions included after design list.**

Note: One spool of 1000 meter thread is adequate for the project unless otherwise noted.

DESIGNS



















Note: Some designs in this collection may have been created using unique special stitches and/or techniques. To preserve design integrity when rescaling or rotating designs in your software, always rescale or rotate designs using the handles directly on-screen.

*Fabric Required

12666-01 Turkey Tail Left FSA



Size Inches: Size mm: Stitch Count:
4.81 X 8.27 in. 122.17 X 210.06 mm 57,887 St.

	1. Number 1 3 5 Feathers Placement Stitch	0015
	2. Number 1 3 5 Feathers Cut Line & Tackdown	0015
	3. Number 2 4 Feathers Placement Stitch	0015
	4. Number 2 4 Feathers Cut Line & Tackdown	0015
	5. Body & Feather 6 Placement Stitch	0015
	6. Body & Feather 6 Cut Line & Tackdown	0015
	7. White Feather Detail	0015
	8. Number 1 Feather Brown Detail.....	1032
	9. Number 2 Feather Orange Detail.....	1311
	10. Number 3 Feather Pink Detail.....	1921
	11. Number 4 Feather Gold Detail	0721
	12. Number 5 Feather Light Orange Detail	1220
	13. Number 1 3 5 Feathers Back Cut Line & Tackdown.....	0731
	14. Number 2 4 Feathers Back Cut Line & Tackdown	0731
	15. Body & Feather 6 Back Cut Line & Tackdown	0731
	16. Light Gold Feather Detail	0731
	17. Body Linework.....	1055
	18. Cover Stitch & Lace	1366

Note: Some designs in this collection may have been created using unique special stitches and/or techniques. To preserve design integrity when rescaling or rotating designs in your software, always rescale or rotate designs using the handles directly on-screen.

***Fabric Required**



12666-02 Turkey Tail Right FSA

Size Inches: Size mm: Stitch Count:
4.74 X 8.27 in. 120.40 X 210.06 mm 58,470 St.

- 1. Number 1 3 5 Feathers Placement Stitch 0015
- 2. Number 1 3 5 Feathers Cut Line & Tackdown 0015
- 3. Number 2 4 Feathers Placement Stitch 0015
- 4. Number 2 4 Feathers Cut Line & Tackdown 0015
- 5. Body & Feather 6 Placement Stitch 0015
- 6. Body & Feather 6 Cut Line & Tackdown 0015
- 7. White Feather Detail 0015
- 8. Number 1 Feather Pink Detail 1921
- 9. Number 2 Feather Gold Detail 0721
- 10. Number 3 Feather Light Orange Detail 1220
- 11. Number 4 Feather Brown Detail 1032
- 12. Number 5 Feather Orange Detail 1311
- 13. Number 1 3 5 Feathers Back Cut Line & Tackdown 0731
- 14. Number 2 4 Feathers Back Cut Line & Tackdown .0731
- 15. Body & Feather 6 Back Cut Line & Tackdown 0731
- 16. Light Gold Feather Detail 0731
- 17. Body Linework 1055
- 18. Cover Stitch & Lace 1366

***Fabric Required**

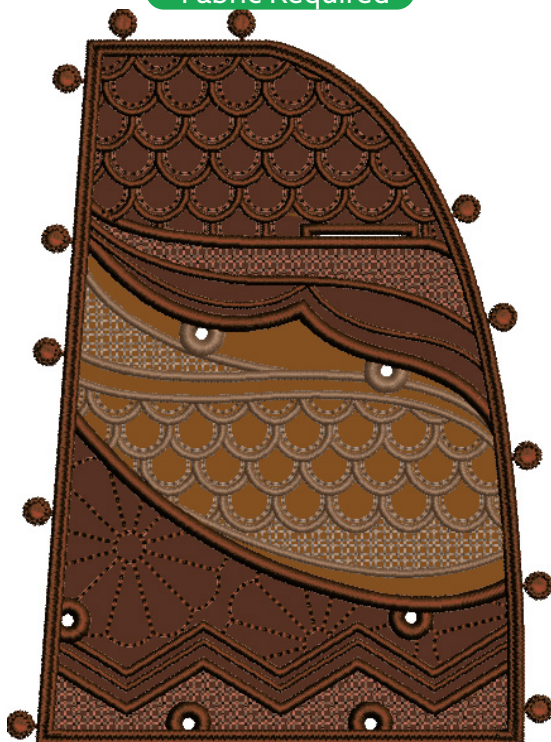

12666-03 Turkey Body Left FSA

Size Inches: Size mm: Stitch Count:
4.48 X 6.07 in. 113.79 X 154.18 mm 29,103 St.

- 1. Center Placement Stitch 1055
- 2. Center Cut Line & Tackdown 1055
- 3. Top & Bottom Placement Stitch 1055
- 4. Top & Bottom Cut Line & Tackdown 1055
- 5. Center Light Brown Detail 1055
- 6. Top & Bottom Detail & Lace 1366

Note: Some designs in this collection may have been created using unique special stitches and/or techniques. To preserve design integrity when rescaling or rotating designs in your software, always rescale or rotate designs using the handles directly on-screen.

***Fabric Required**



12666-04 Turkey Body Right FSA

Size Inches: Size mm: Stitch Count:
4.39 X 5.99 in. 111.51 X 152.15 mm 29,606 St.

- 1. Center Placement Stitch 1055
- 2. Center Cut Line & Tackdown..... 1055
- 3. Top & Bottom Placement Stitch..... 1055
- 4. Top & Bottom Cut Line & Tackdown..... 1055
- 5. Center Light Brown Detail 1055
- 6. Top & Bottom Detail & Lace 1366

***Fabric Required**

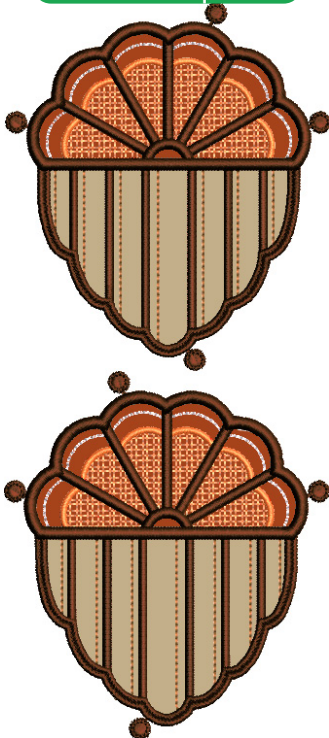

12666-05 Turkey Wings FSA

Size Inches: Size mm: Stitch Count:
3.49 X 7.90 in. 88.65 X 200.66 mm 19,050 St.

- 1. Wing Tops Placement Stitch 0015
- 2. Wing Tops Cut Line & Tackdown..... 0015
- 3. Wing Bottoms Placement Stitch..... 0015
- 4. Wing Bottoms Cut Line & Tackdown 0015
- 5. White Detail 0015
- 6. Light Orange Detail 1220
- 7. Light Brown Detail 1032
- 8. Cover Stitch & Lace 1366

Note: Some designs in this collection may have been created using unique special stitches and/or techniques. To preserve design integrity when rescaling or rotating designs in your software, always rescale or rotate designs using the handles directly on-screen.

***Fabric Required**

12666-06 Turkey Head FSA

Size Inches: Size mm: Stitch Count:
4.94 X 3.81 in. 125.48 X 96.77 mm 16,617 St.

- 1. Head Placement Stitch..... 1032
- 2. Head Cut Line & Tackdown..... 1032
- 3. Light Brown Detail..... 1032
- 4. Beak..... 1220
- 5. Cover Stitch & Lace..... 1366
- 6. Snood..... 1921

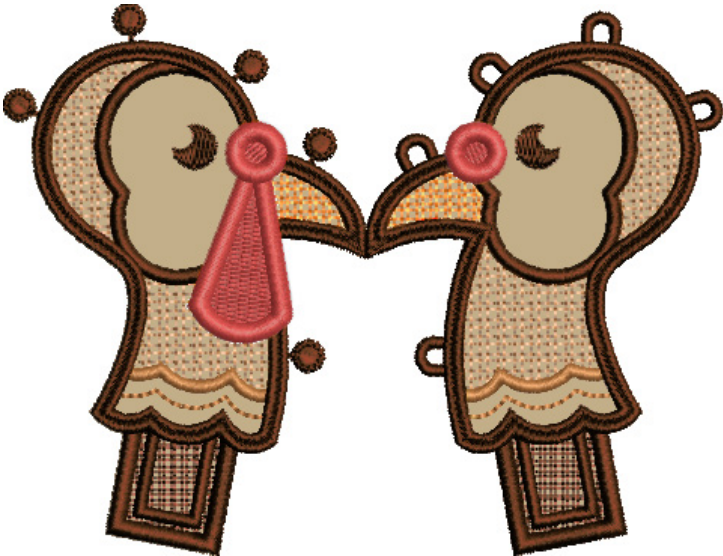

***Fabric Required**

12666-07 Turkey Base FSA

Size Inches: Size mm: Stitch Count:
3.58 X 3.61 in. 90.93 X 91.69 mm 11,773 St.

- 1. Base Placement Stitch..... 1366
- 2. Base Cut Line & Tackdown..... 1366
- 3. Inner Detail & Lace..... 1366

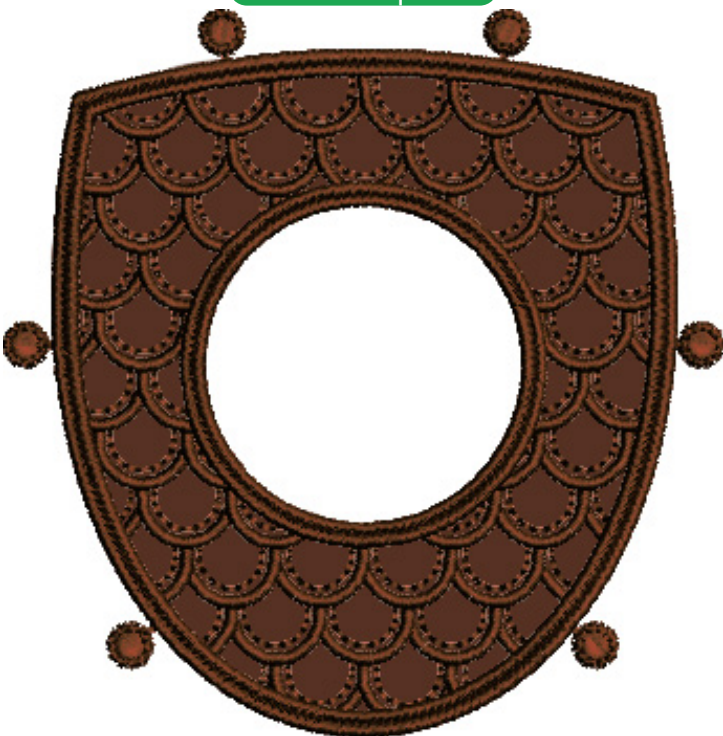

Stabilizers

- OESD AquaMesh WashAway
- OESD BadgeMaster WashAway
- OESD StabilStick CutAway

Fabrics/Textiles

- 1 Fat quarter of each:
Brown, Yellow, Orange, Rust, Tan, Beige
- Note: Fabric sizes are estimates and may result in overage.

Notions & Tools

- OESD Alligator Clamps
- OESD Button Clips
- OESD Perfect Embroidery Press Cloth
- OESD Expert Embroidery Tape TearAway
- OESD Expert Embroidery Tape WashAway
- OESD Perfect Punch Tool
- Embroidery Needle Sharp size 75/11

Isacord Thread Colors

- Per thread chart
- Match the bobbin thread to the upper thread

SUMMARY

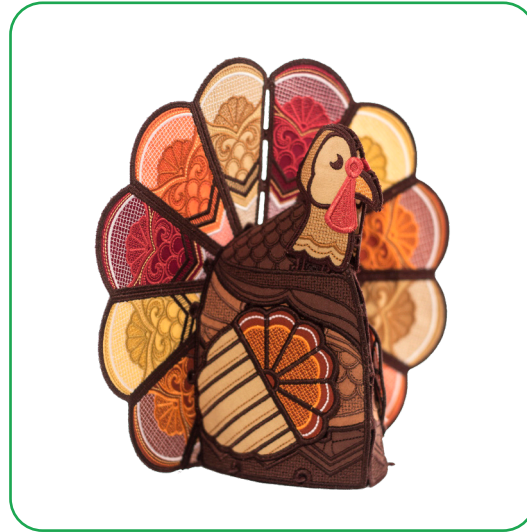

Completed Size: 8 1/4" H x 9 1/4" W x 3 3/4" D

12666-01

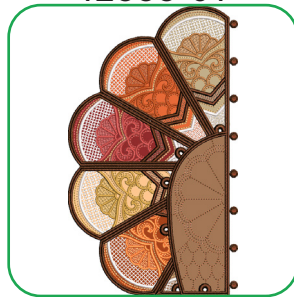

Requires 1 Design

12666-02

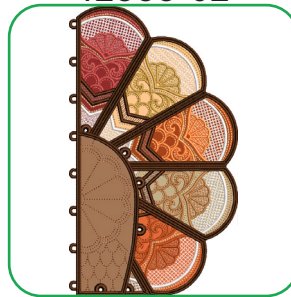

Requires 1 Design

12666-03



Requires 1 Design

12666-04



Requires 1 Design

12666-05

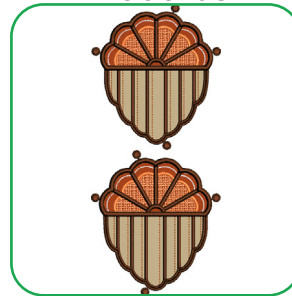

Requires 1 Design

12666-06



Requires 1 Design

12666-07

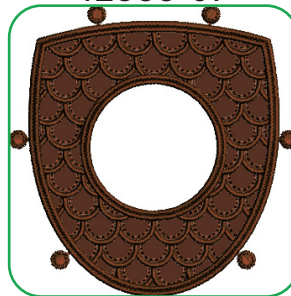

Requires 1 Design

Notes

- The freestanding applique instructions, included in the collection, are general instructions. For demonstration purposes, a sample design (12666-01) that best demonstrates the technique is shown.
- Fabric and thread requirements will vary by design, but the general technique is the same.
- All designs are stitched with matching thread in the top and bobbin.
- Note: Some thread colors in instructions have been changed or digitally enhanced for better visibility.

Double Sided Applique Technique

For Turkey Tail pieces 12666-01 and 12666-02

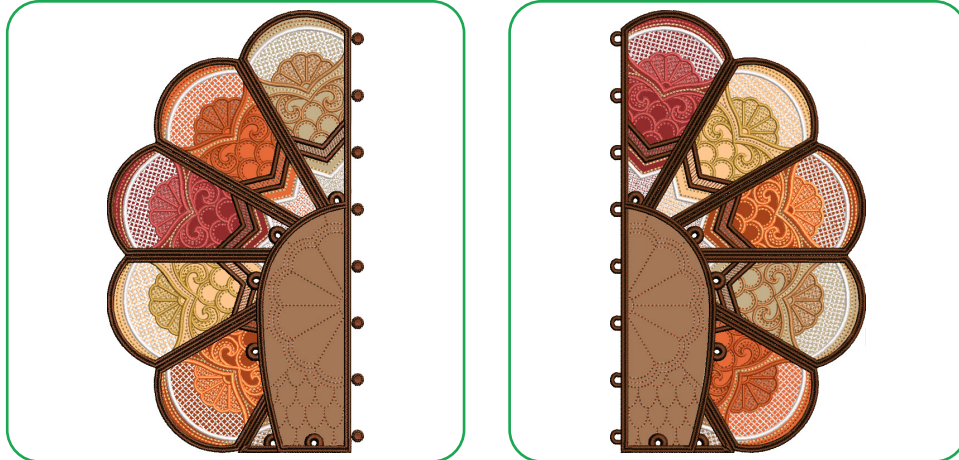

EMBROIDERY



STEP 1

- Hoop one layer of AquaMesh and one layer of BadgeMaster for all designs.



STEP 2

- Adhere one layer of StabilStick CutAway to the wrong side of all fabrics as shown. This provides stiffness to the finished structure.
- Cut the prepared applique fabrics 1/4" -1/2" larger than the templates that are included at the end of the instructions.

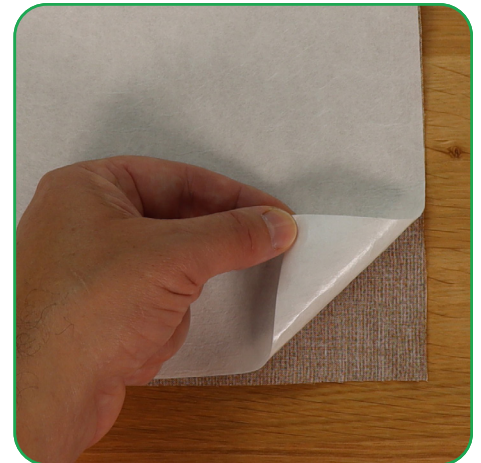

STEP 3

- Load selected design into the machine.
- Design in the example is 12666-01.
- Thread the machine per the thread chart, matching bobbin thread to the top thread throughout.
- Stitch Machine Step 1, Number 1 3 5 Feathers Placement Stitch.



STEP 4

- Remove the hoop from the machine, but NOT the project from the hoop.
- Lay the hoop on a flat surface.
- Place the prepared brown applique fabric, right side up, completely covering the placement stitch closest to you.
- Place the prepared rust applique fabric, right side up, completely covering the middle placement stitch.
- Place the prepared beige applique fabric, right side up, completely covering the last placement stitch.
- Tape in place to secure.
- Note: Be sure none of the fabrics overlap each other.



STEP 5

- Return the hoop to the machine.
- Stitch Machine Step 2, Number 1 3 5 Feathers Cut Line & Tackdown.



STEP 6

- Remove the hoop from the machine, but NOT the project from the hoop.
- Place the hoop on a flat surface.
- Trim the excess fabric as close to the cut line as possible. If the outermost stitches (cut line) are cut, the inner stitches (tackdown) will hold the applique in place.
- Tip: If the AquaMesh is cut or a hole is created while trimming the fabric, use OESD Expert Embroidery Tape WashAway as a patch.
- Helpful Hint: If it is difficult to trim the applique fabric for the buttonette connections, leave it and once the project pieces have been stitched, rinsed, dried, and pressed, used the OESD Perfect Punch Tool with the 2mm cutting tip to punch out the eyelets.



STEP 7

- Return the hoop to the machine.
- Stitch Machine Step 3, Number 2 4 Feathers Placement Stitch.



STEP 8

- Remove the hoop from the machine, but NOT the project from the hoop.
- Lay the hoop on a flat surface.
- Place the prepared yellow applique fabric, right side up, completely covering the placement stitch closest to you.
- Place the prepared orange applique fabric, right side up, completely covering the last placement stitch.
- Tape in place to secure.
- Note: Be sure the yellow and orange applique fabrics do not overlap.



STEP 9

- Return the hoop to the machine.
- Stitch Machine Step 4, Number 2 4 Feathers Cut Line & Tackdown.



STEP 10

- Remove the hoop from the machine, but NOT the project from the hoop.
- Lay the hoop on a flat surface.
- Trim the excess fabric as close to the cut line as possible.



STEP 11

- Return the hoop to the machine.
- Stitch Machine Step 5, Body & Feather 6 Placement Stitch.



STEP 12

- Remove the hoop from the machine, but NOT the project from the hoop.
- Lay the hoop on a flat surface.
- Place the prepared tan applique fabric, right side up, completely covering the placement stitch.
- Tape in place to secure.
- Return the hoop to the machine.
- Stitch Machine Step 6, Body & Feather 6 Cut Line & Tackdown.



STEP 13

- Remove the hoop from the machine, but NOT the project from the hoop.
- Lay the hoop on a flat surface.
- Trim the excess fabric as close to the cut line as possible.



EMBROIDERY



STEP 14

- Return the hoop to the machine.
- Stitch Machine Steps 7 - 12, per thread chart.



STEP 15

- Before stitching Machine Step 13, remove the hoop from the machine, but NOT the project from the hoop.
- Turn the hoop over and place the prepared applique fabrics for feathers 1, 3 and 5, right side up, completely covering the placement stitch.
- Note: Match the bottom fabrics to the fabrics already placed on the top side of the hoop.
- Carefully tape to secure. Avoid pushing too hard on the stabilizer to prevent it from dislodging from the hoop.



STEP 16

- Return the hoop to the machine, be careful not to dislodge the fabric.
- Stitch Machine Step 13; Number 1 3 5 Feathers Back Cut Line & Tackdown.



STEP 17

- Remove the hoop from the machine, but NOT the project from the hoop.
- Turn the hoop over and carefully trim the excess fabric as close to the cut line as possible.



STEP 18

- Place the prepared applique fabrics for Feathers 2 and 4, right side up, completely covering the placement stitch.
- Note: Match the bottom fabrics to the fabrics already placed on the top side of the hoop.
- Carefully tape to secure. Avoid pushing too hard on the stabilizer to prevent it from dislodging from the hoop.



STEP 19

- Return the hoop to the machine, be careful not to dislodge the fabric.
- Stitch Machine Step 14, Number 2 4 Feathers Back Cut Line & Tackdown.



EMBROIDERY



STEP 20

- Remove the hoop from the machine, but NOT the project from the hoop.
- Turn the hoop over and carefully trim the excess fabric as close to the cut line as possible.



STEP 21

- Place the prepared applique fabrics for the Body, right side up, completely covering the placement stitch.
- Note: Match the bottom fabric to the fabric already placed on the top side of the hoop.
- Carefully tape to secure. Avoid pushing too hard on the stabilizer to prevent it from dislodging from the hoop.



STEP 22

- Stitch Machine Step 15, Body & Feather 6 Back Cut Line and Tackdown.



STEP 23

- Remove the hoop from the machine, but NOT the project from the hoop.
- Turn the hoop over and carefully trim the excess fabric as close to the cut line as possible.



STEP 24

- Return the hoop to the machine.
- Stitch Machine Steps 16-18, matching bobbin to top threads.



STEP 25

- When the design is complete, remove the project from the hoop and trim the stabilizer 1/4" - 1/2" outside the design.



General Freestanding Applique Technique

12666-03 through 12666-07

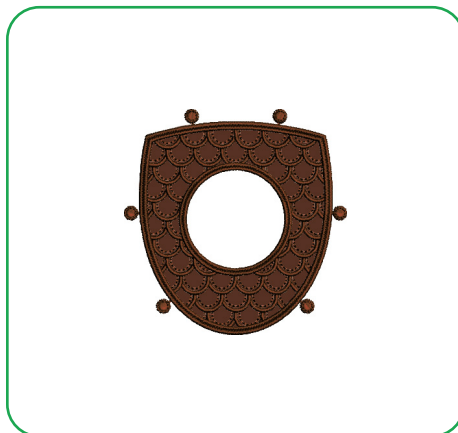
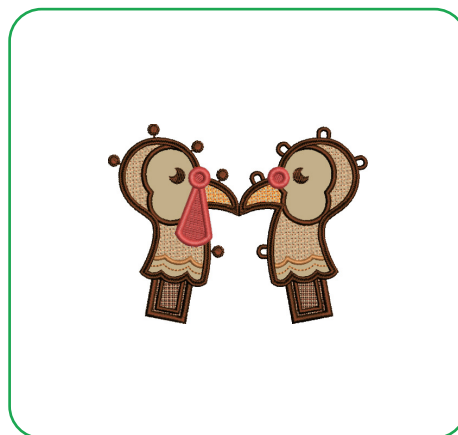
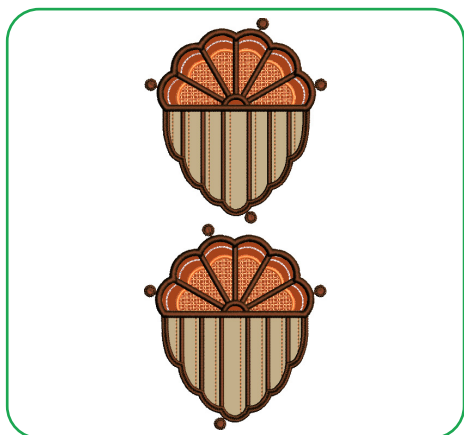

STEP 26

- Hoop one layer of AquaMesh and one layer of BadgeMaster for all designs.



STEP 27

- Adhere two layers of StabilStick CutAway to the wrong side of all applique fabrics, to provide stiffness to the finished structure.
- Cut the prepared applique fabrics 1/4" -1/2" larger than the templates that are included at the end of the instructions.

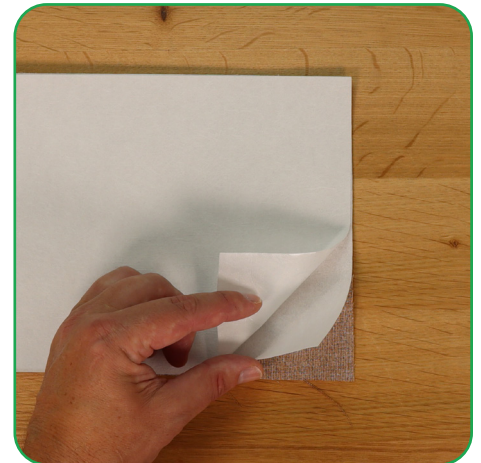

STEP 28

- Load selected design into the machine.
- Design in the example is 12666-03.
- Thread the machine per the thread chart, matching bobbin thread to the top thread throughout.
- Stitch Machine Step 1, Center Placement Stitch.



EMBROIDERY



STEP 29

- Remove the hoop from the machine, but NOT the project from the hoop.
- Lay the hoop on a flat surface.
- Place the prepared applique fabric, right side up, completely covering the placement stitch.
- Tape in place to secure.



STEP 30

- Return the hoop to the machine.
- Stitch Machine Step 2, Center Cut Line & Tackdown.



STEP 31

- Remove the hoop from the machine, but NOT the project from the hoop.
- Place the hoop on a flat surface.
- Trim the excess fabric as close to the cut line as possible. If the outermost stitches (cut line) are cut, the inner stitches (tackdown) will hold the applique in place.
- Tip: If the AquaMesh is cut or a hole is created while trimming the fabric, use OESD Expert Embroidery Tape WashAway as a patch.



STEP 32

- Return the hoop to the machine.
- Stitch Machine Step 3, Top & Bottom Placement Stitch.



STEP 33

- Remove the hoop from the machine, but NOT the project from the hoop.
- Lay the hoop on a flat surface.
- Place the prepared applique fabric, right side up, completely covering the placement stitch.
- Tape in place to secure.



STEP 34

- Return the hoop to the machine.
- Stitch Machine Step 2, Top & Bottom Cut Line & Tackdown.



STEP 35

- Remove the hoop from the machine, but NOT the project from the hoop.
- Place the hoop on a flat surface.
- Trim the excess fabric as close to the cut line as possible.



STEP 36

- Return the hoop to the machine.
- Stitch Machine Steps 5 and 6, matching bobbin to top threads.



STEP 37

- When the design is complete, remove the project from the hoop and trim the stabilizer 1/4" - 1/2" outside the design.

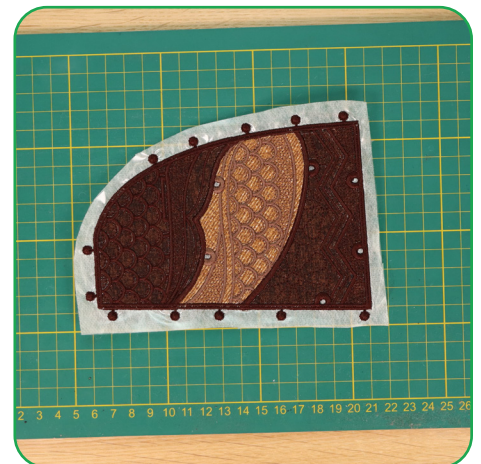

ASSEMBLY



STEP 38

- Rinse each piece in warm running water until the design is only slightly tacky.
- Place right side down on a non-stick surface to dry. Parchment paper or a cooling rack will prevent curling. Dry completely.
- Once dry, press right side down on a Perfect Embroidery Press Cloth.



STEP 39

- If the eyelets need to be punched, using the OESD Perfect Punch Tool fitted with the 2mm tip, punch out the eyelets on all Freestanding Dresden Turkey sections, designs number 12666-01, 12666-02, 12666-03, and 12666-04.



STEP 40

- Before assembly, use a utility knife to cut through all the layers of the tab entry for Turkey Body Left FSA (12666-03) and Turkey Body Right FSA (12666-04). Take care to not cut the satin stitching.



ASSEMBLY



STEP 41

- Assemble Turkey Tail Left FSA (12666-01) to Turkey Tail Right FSA (12666-02). Match the eyelets to the buttonettes. Pull each buttonette through the corresponding eyelet to the backside. Attach a button clip to hold the eyelet in place temporarily when needed.

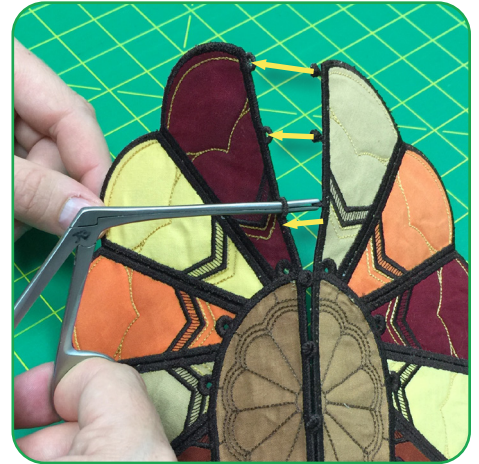

STEP 42

- Assemble Turkey Wings FSA (12666-05) to Turkey Body Left and Right FSA (12666-03 & 12666-04). Match the four buttonettes on each wing to the four eyelets on each body. Pull each buttonette through the corresponding eyelet to the backside.



STEP 43

- Attach Turkey Body Left FSA (12666-03) to Turkey Body Right FSA (12666-04). Match the eyelets to the buttonettes. Pull each buttonette through the corresponding eyelet. Attach a button clip to hold the eyelet in place temporarily when needed.

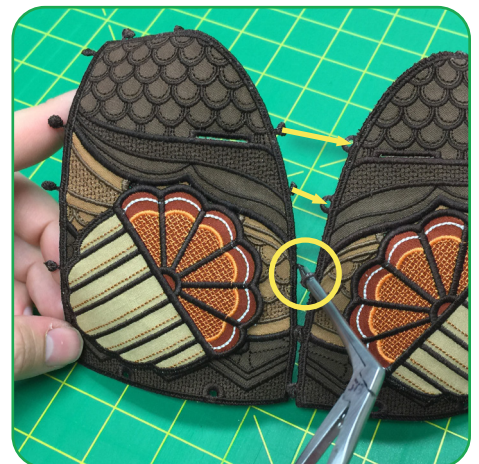

ASSEMBLY

STEP 44

- Attach Turkey Base FSA (12666-07) Turkey Body. Match the eyelets to the buttonettes. Pull each buttonette through the corresponding eyelet. Attach a button clip to hold the eyelet in place temporarily when needed. Be sure the pointed ends of the base face to the back of the turkey.



STEP 45

- Assemble the Turkey Head FSA (12666-06), pull each buttonette through the corresponding eyelet.



STEP 46

- Attach the Turkey Head FSA (12666-06) by pulling the tabs through the slits on the top of the Turkey Body.
- Note: After putting the tabs into the slots, twist them slightly to help them stay in place, or use Button Clips for a temporary hold.



ASSEMBLY

STEP 47

- Attach the body and base to the tail. Match the eyelets to the buttonettes. Pull each buttonette through the corresponding eyelet.

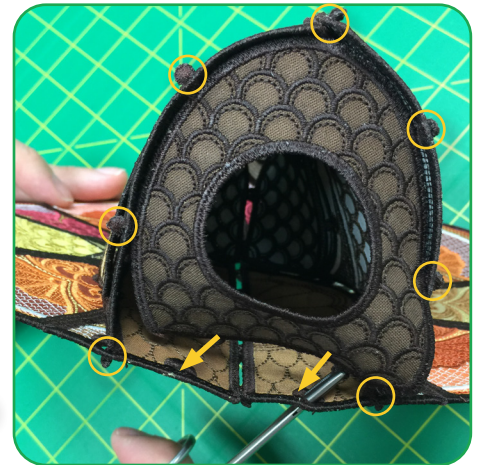

ASSEMBLY



Finishing Touches

- Add tea lights or pixie lights to create a glow.
- Enjoy!



Stabilizer

- OESD AquaMesh
- OESD BadgeMaster

Notions/Tools

- 80/12 Embroidery Ballpoint Titanium needle for extended needle life
- OESD Alligator Clamps
- OESD Button Clips
- OESD Perfect Point and Press Tool

Isacord Thread Colors

- All OESD designs are digitized with Isacord 40 wt. polyester thread as the top thread and in the bobbin.
- Refer to the thread chart for color specifications.
- Match bobbin thread color to the top thread.

Instructions

Step 1 - Hoop

For FSL structures, hoop one layer of OESD AquaMesh and one layer of OESD BadgeMaster. BadgeMaster contains more starch so, combined with the AquaMesh, the lace is more rigid. For other FSL, where a softer lace is desired, hoop two layers of AquaMesh.

Step 2 - Embroider

Stitch the design per the thread chart with matching thread in the bobbin at each color change. When complete, remove from the hoop and trim away excess stabilizer about 1/4"-1/2" from the stitching.

Step 3 - Rinse

Rinse remaining stabilizer out in warm running water. For stiffer lace and FSL structures, DO NOT rinse away all of the stabilizer. The lace should be just slightly tacky. For softer lace, rinse until all traces of the stabilizer are removed.

Step 4 - Dry

Lay right side down flat on a non-stick surface, such as a cooling rack, parchment paper or Teflon sheet. This minimizes the tendency for the lace to curl. Let the pieces dry completely before proceeding with any assembly.

Step 5 - Press

Once completely dry, press right side down on a OESD Perfect Embroidery Press Cloth.

Step 6 - Assemble Structure

Note: Specific assembly instructions for a design/collection may be found in the thread chart pdf following the individual design color charts.

Lace must be COMPLETELY DRY before assembly. Wetting the buttonettes or eyelets to assemble is not recommended and may result in them stretching and coming "unbuttoned" when dry.

Use a pair of OESD Alligator Clamps to insert the buttonettes into the eyelets. Insert the tip of the OESD Alligator Clamps into the eyelet, grasp the buttonette and pull through the eyelet. Alternatively, use a stiletto or tweezers to push the buttonette through the eyelet.

Helpful Tips

Limp Lace

If the design is not stiff enough, press the lace pieces on the wrong side while applying spray starch. After ironing, spray again with starch and allow to dry completely. This will stiffen the lace pieces nicely and aid in construction. Or easily re-stiffen by diluting some stabilizer scraps in water (or use liquid starch) and dipping the item in the solution. Lay flat to dry.

Eyelets Too Small

If any of the eyelets appear closed or too small to penetrate with Alligator Clamps, they may be stretched by inserting the small end of the OESD Perfect Point and Press Tool into the eyelet opening and stretching it open wide enough to accommodate the OESD Alligator Clamps.

Button Clips

During the assembly process, some structures pull on buttonettes that have already been inserted and could pull them out altogether. Putting a Button Clip on the assembled buttonette will keep it in position during the assembly process. Remove the Button Clips when the assembly is complete.

Alternative Construction Option

In some cases, the buttonettes may be pulled to the inside of a project, instead of being visible on the outside. Insert the OESD Alligator Clamps through the eyelet from the wrong, or inside, of the lace and grasp the corresponding buttonette. Pull the buttonette to the wrong side of the lace. Pulling the buttonettes to the inside may cause stress on the ones already done. Button clips may be placed on the completed buttonette(s) to prevent them from pulling out of the eyelet during construction.

APPLIQUE PATTERNS



Print at 100%. No scaling. This box measures 1" x 1". Use the box as an accuracy guide when printing templates.

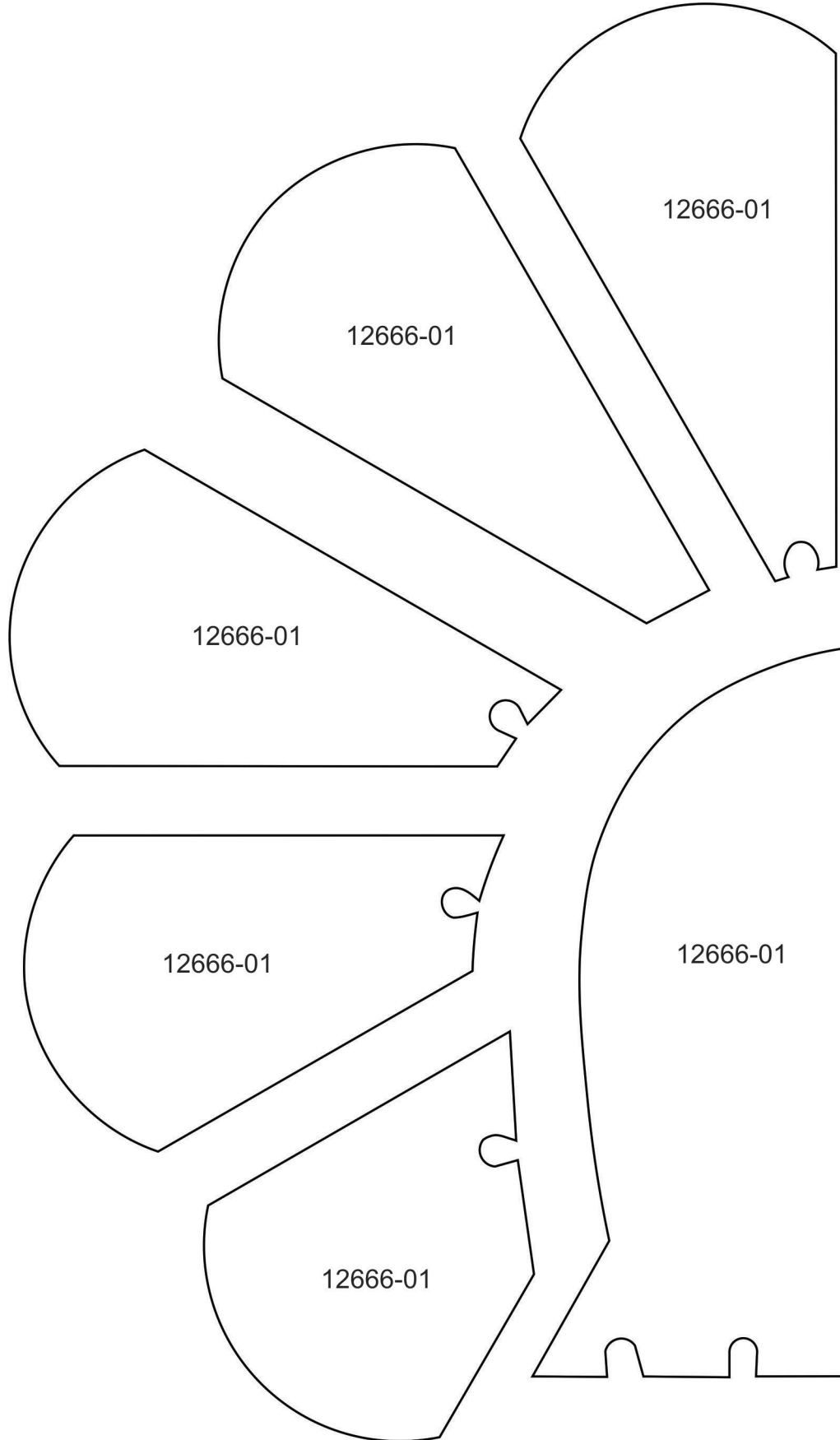

APPLIQUE PATTERNS



Print at 100%. No scaling. This box measures 1" x 1". Use the box as an accuracy guide when printing templates.

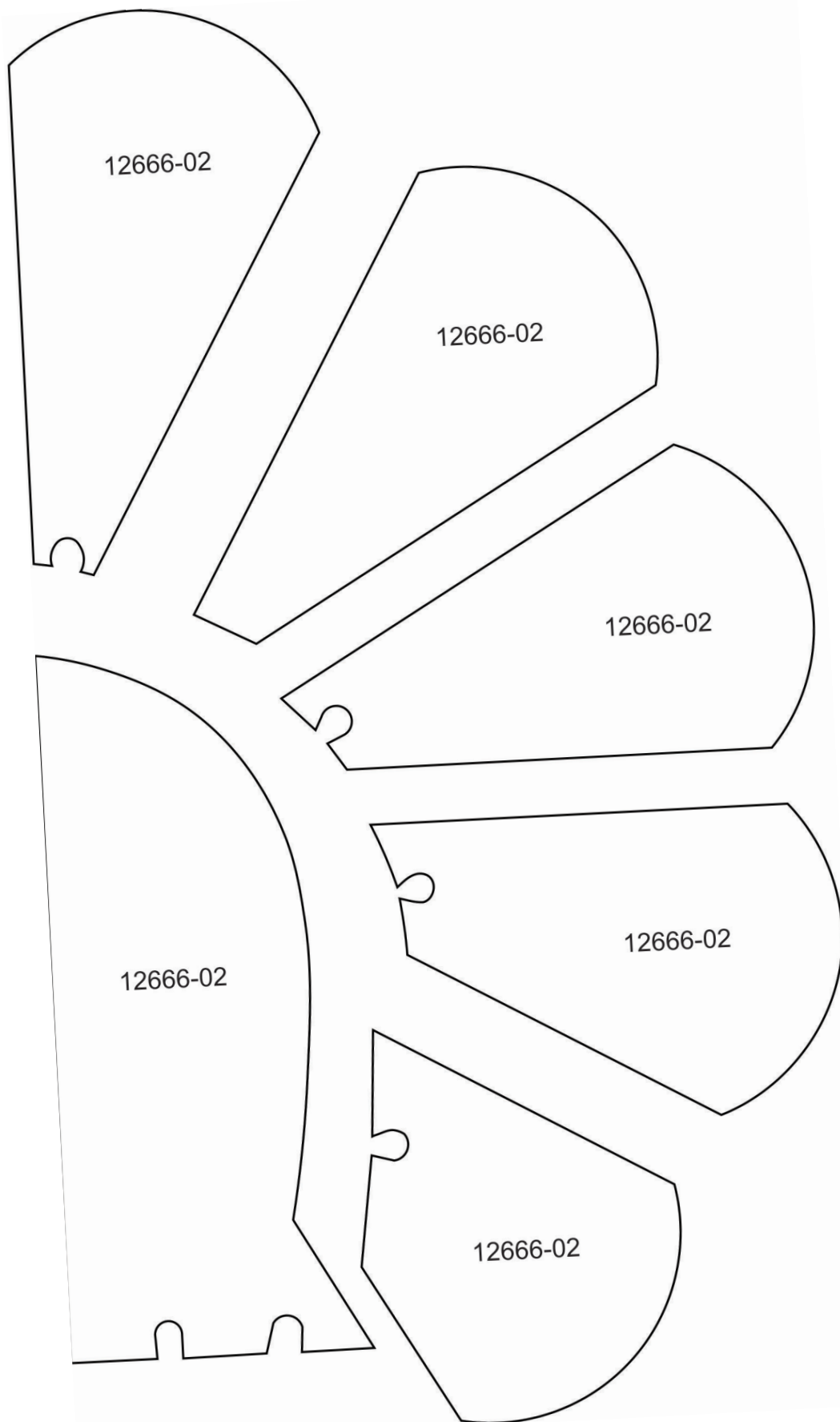

APPLIQUE PATTERNS



Print at 100%. No scaling. This box measures 1" x 1". Use the box as an accuracy guide when printing templates.

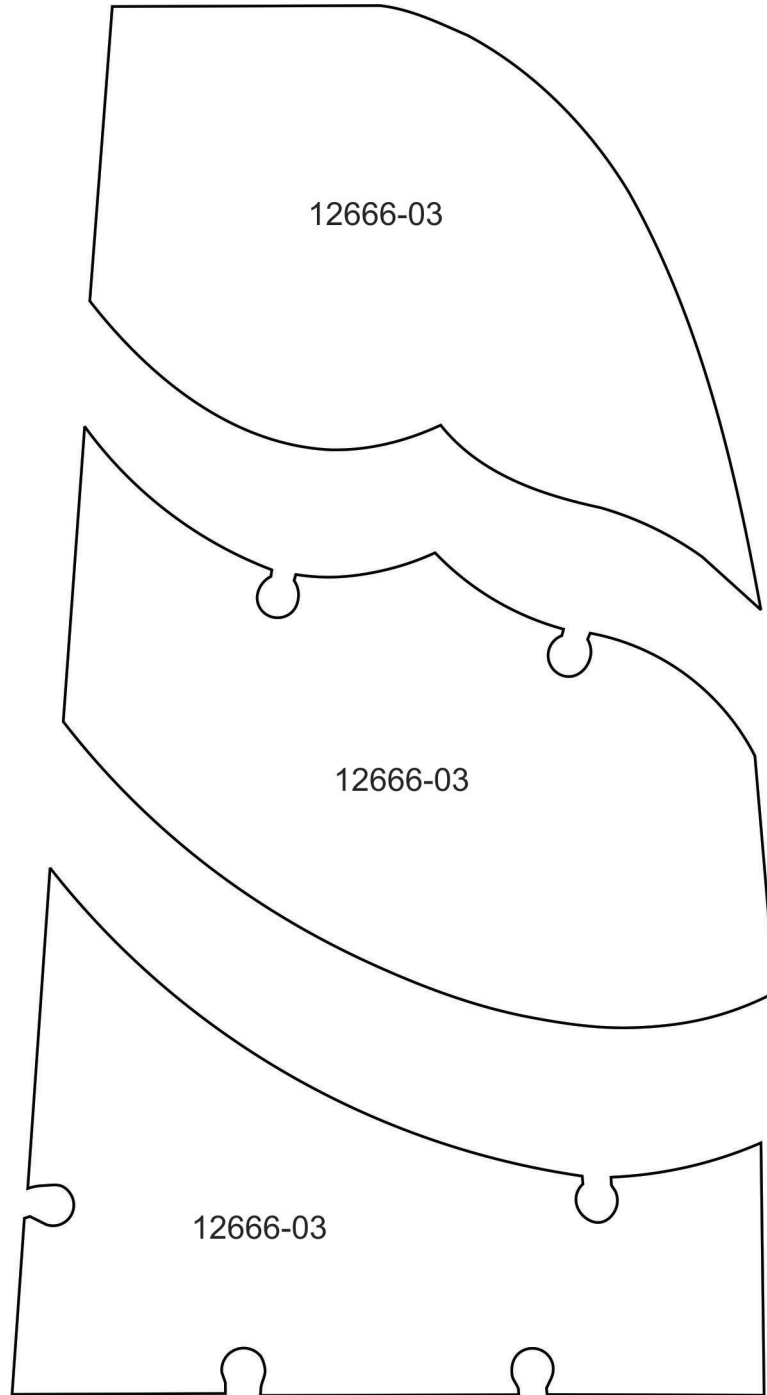

APPLIQUE PATTERNS



Print at 100%. No scaling. This box measures 1" x 1". Use the box as an accuracy guide when printing templates.

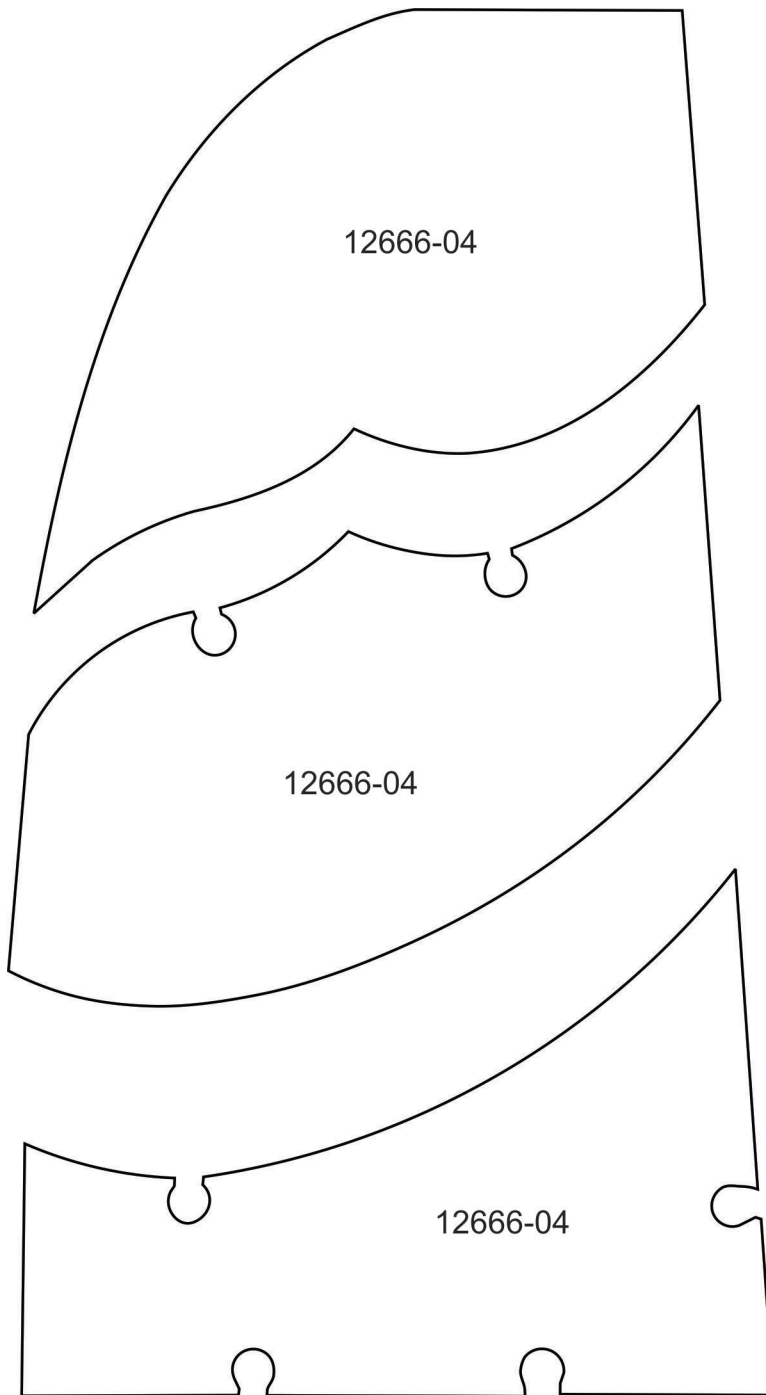

APPLIQUE PATTERNS



Print at 100%. No scaling. This box measures 1" x 1". Use the box as an accuracy guide when printing templates.

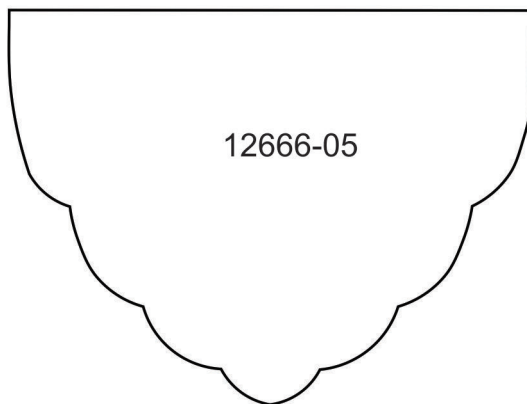
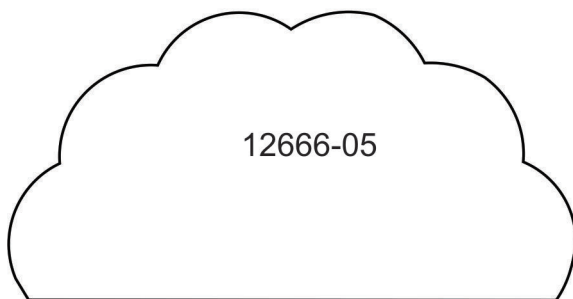
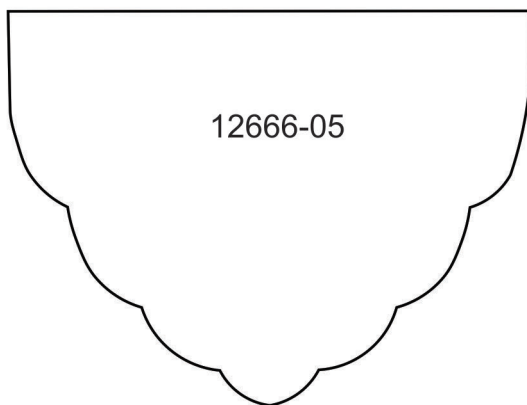
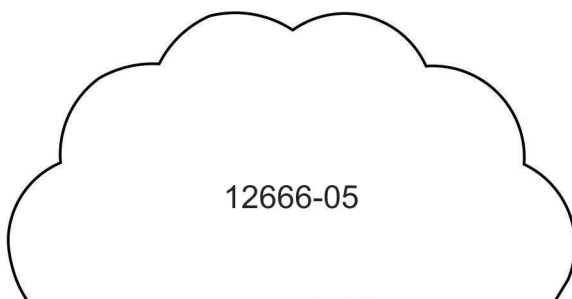

APPLIQUE PATTERNS



Print at 100%. No scaling. This box measures 1" x 1". Use the box as an accuracy guide when printing templates.

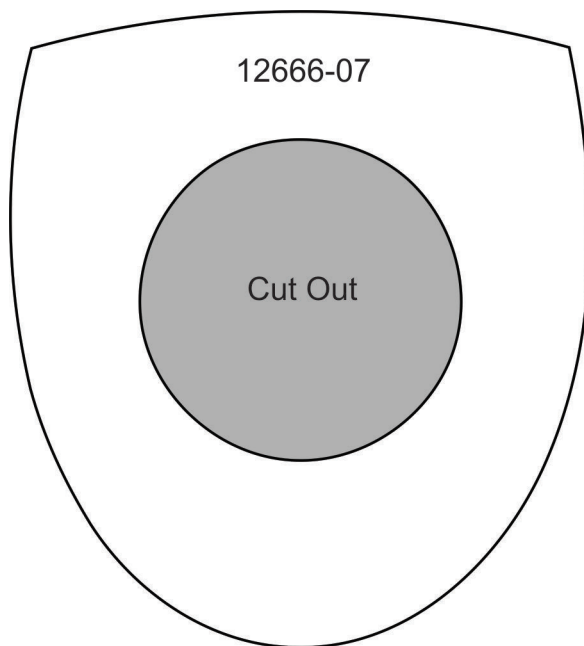
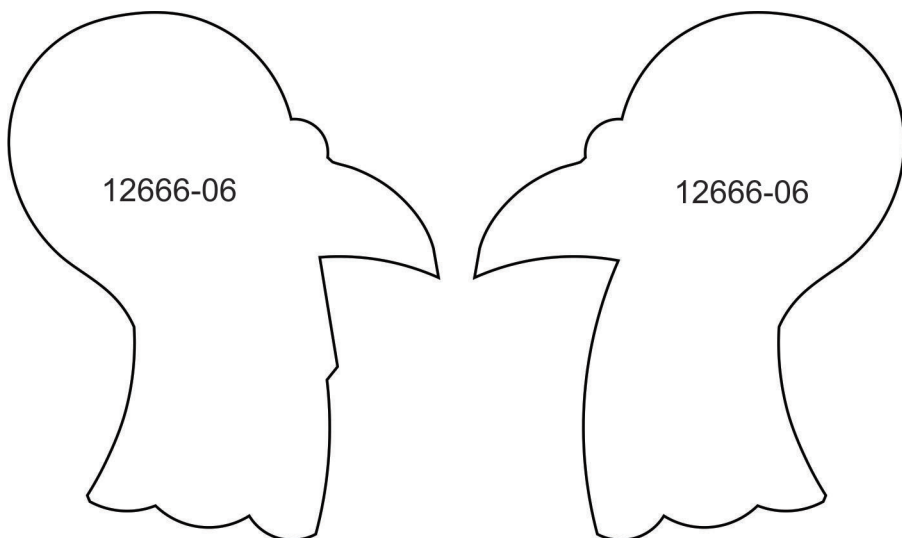

MIRRORED PATTERNS



Print at 100%. No scaling. This box measures 1" x 1". Use the box as an accuracy guide when printing templates.

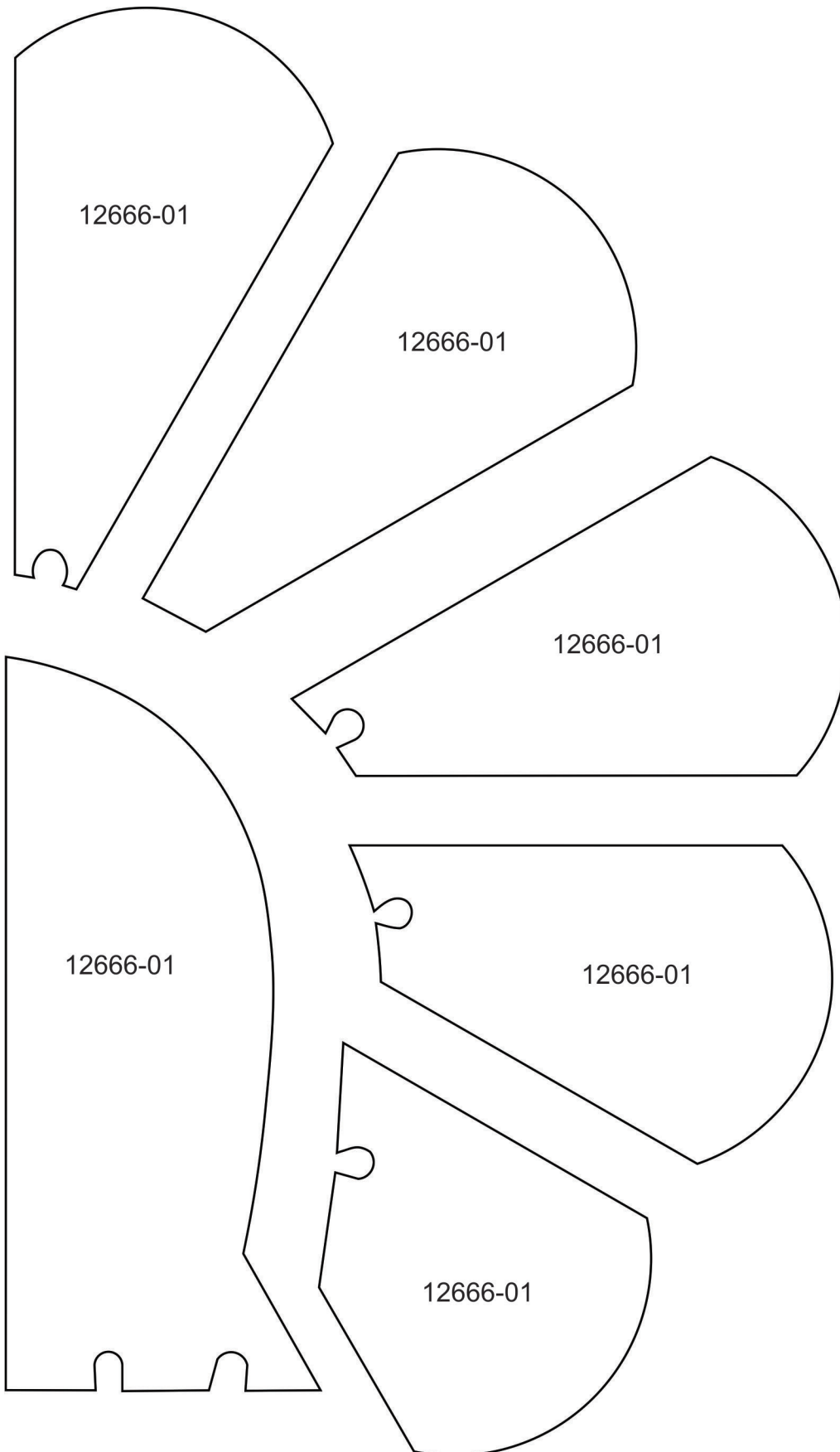

MIRRORED PATTERNS



Print at 100%. No scaling. This box measures 1" x 1". Use the box as an accuracy guide when printing templates.

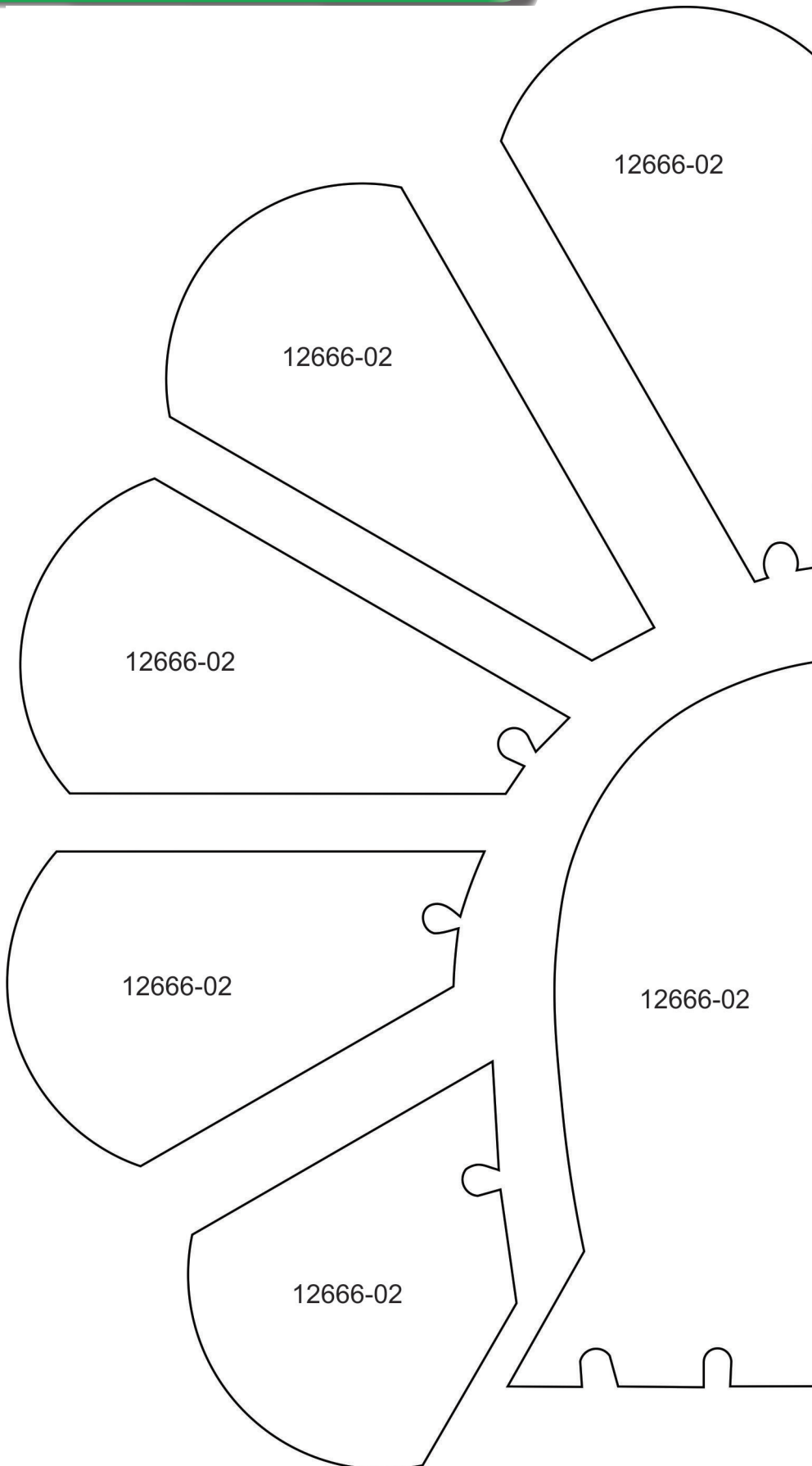

MIRRORED PATTERNS



Print at 100%. No scaling. This box measures 1" x 1". Use the box as an accuracy guide when printing templates.

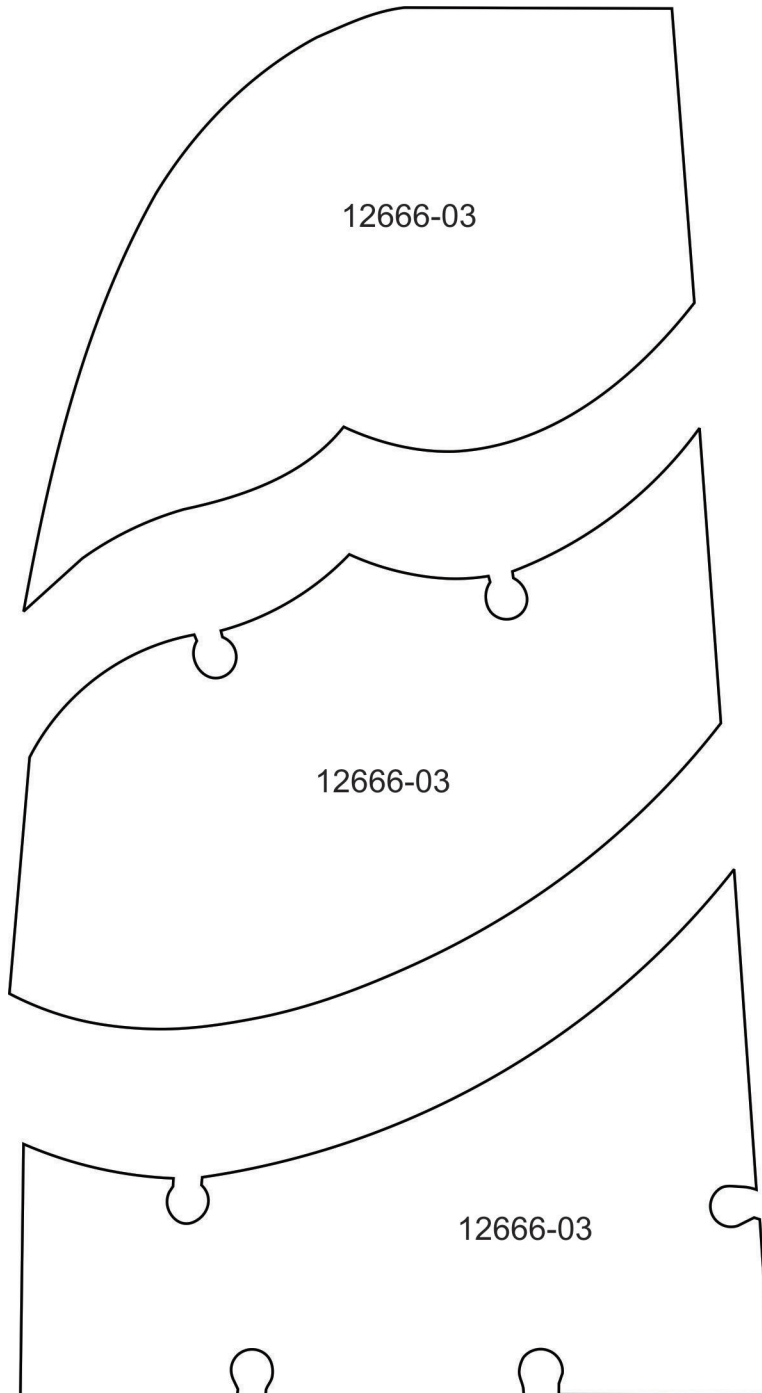

MIRRORED PATTERNS



Print at 100%. No scaling. This box measures 1" x 1". Use the box as an accuracy guide when printing templates.

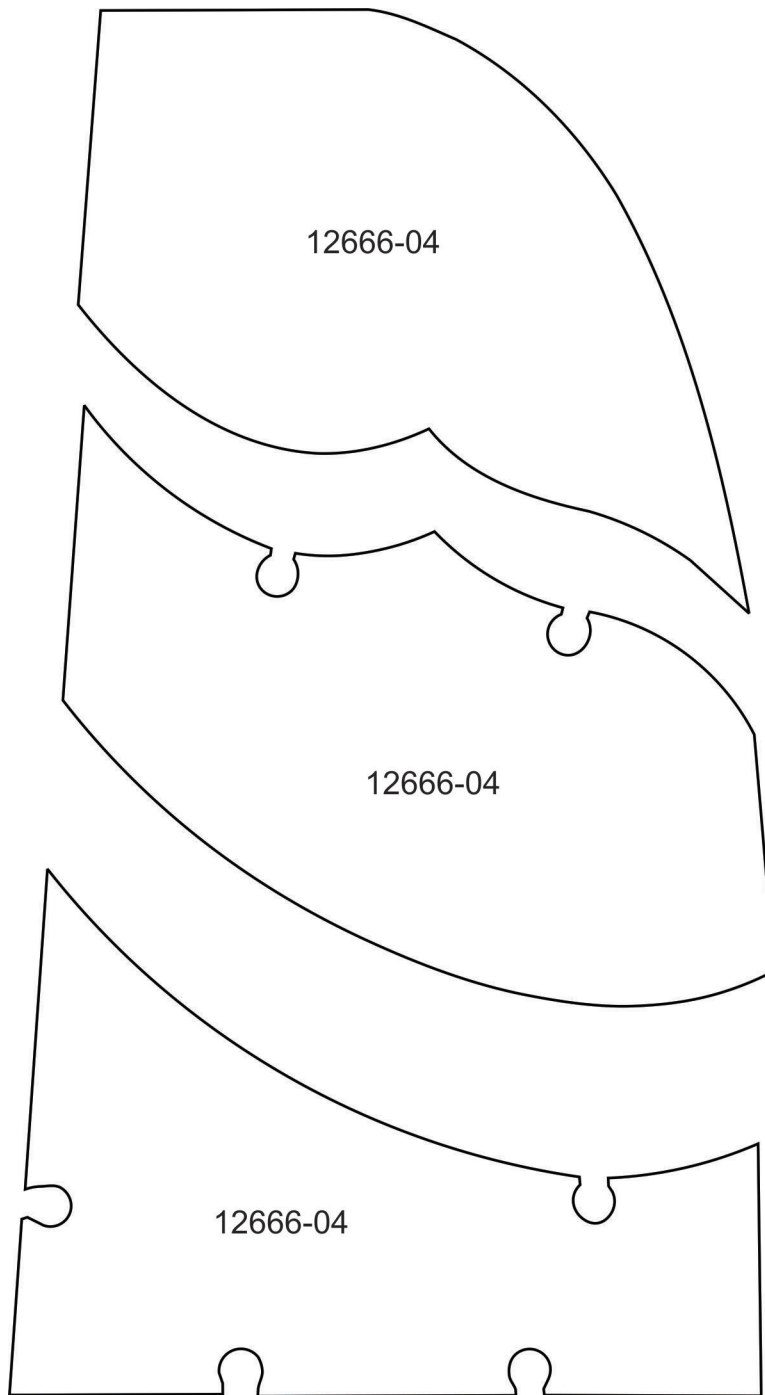

MIRRORED PATTERNS



Print at 100%. No scaling. This box measures 1" x 1". Use the box as an accuracy guide when printing templates.

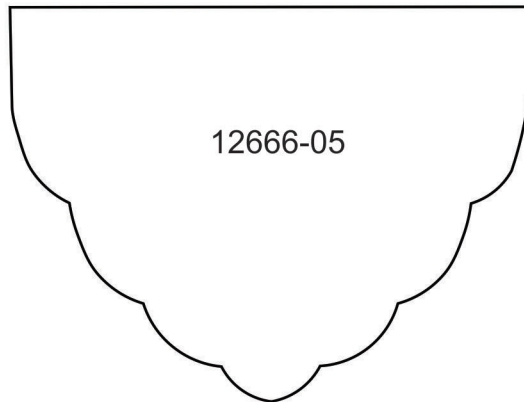
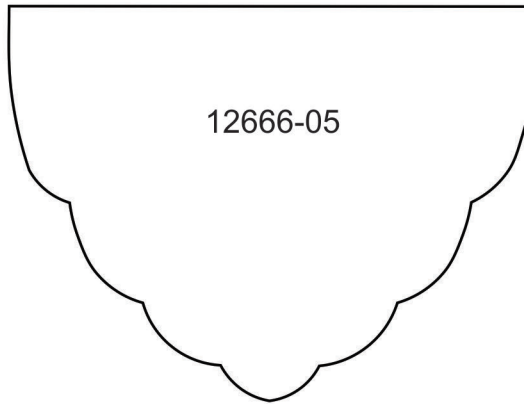
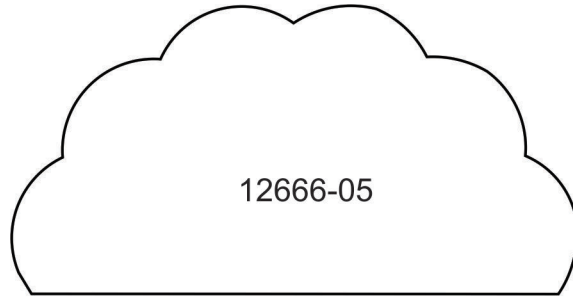

MIRRORED PATTERNS



Print at 100%. No scaling. This box measures 1" x 1". Use the box as an accuracy guide when printing templates.

