



FREESTANDING Police Station



1
Design

Fits hoop size 6" x 10" and larger

THREAD LIST



Isacord Thread Colors

0015 White (3 spools)

*** Project instructions included after design list.**

Note: One spool of 1000 meter thread is adequate for the project unless otherwise noted.

DESIGNS

Note: Some designs in this collection may have been created using unique special stitches and/or techniques. To preserve design integrity when rescaling or rotating designs in your software, always rescale or rotate designs using the handles directly on-screen.

***Fabric Required**



12845-01 Front Wall FSA

Size Inches: Size mm: Stitch Count:
7.02 X 3.77 in. 178.3 X 95.7 mm 51954 St.

- 1. White Fabric Placement Stitch 0015
- 2. Cut Line and Tackdown 0015
- 3. Cream Fabric Placement Stitch..... 0015
- 4. Cut Line and Tackdown 0015
- 5. White Fabric Placement Stitch 0015
- 6. Cut Line and Tackdown 0015
- 7. Cream Fabric Placement Stitch..... 0015
- 8. Cut Line and Tackdown 0015
- 9. Lace and Cover Stitch 0015

Note: Some designs in this collection may have been created using unique special stitches and/or techniques. To preserve design integrity when rescaling or rotating designs in your software, always rescale or rotate designs using the handles directly on-screen.

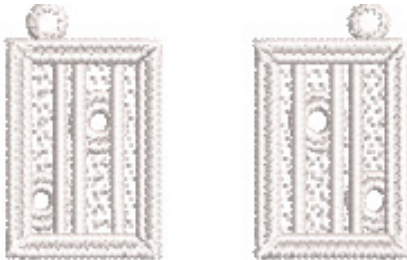

12845-02 Front Steps FSL

Size Inches: Size mm: Stitch Count:
3.65 X 2.46 in. 92.8 X 62.5 mm 19351 St.

1. Single Color Design..... 0015



12845-03 Front Lamps FSL

Size Inches: Size mm: Stitch Count:
2.79 X 3.19 in. 70.8 X 81.0 mm 15384 St.

1. Single Color Design..... 0015



Note: Some designs in this collection may have been created using unique special stitches and/or techniques. To preserve design integrity when rescaling or rotating designs in your software, always rescale or rotate designs using the handles directly on-screen.

***Fabric Required**

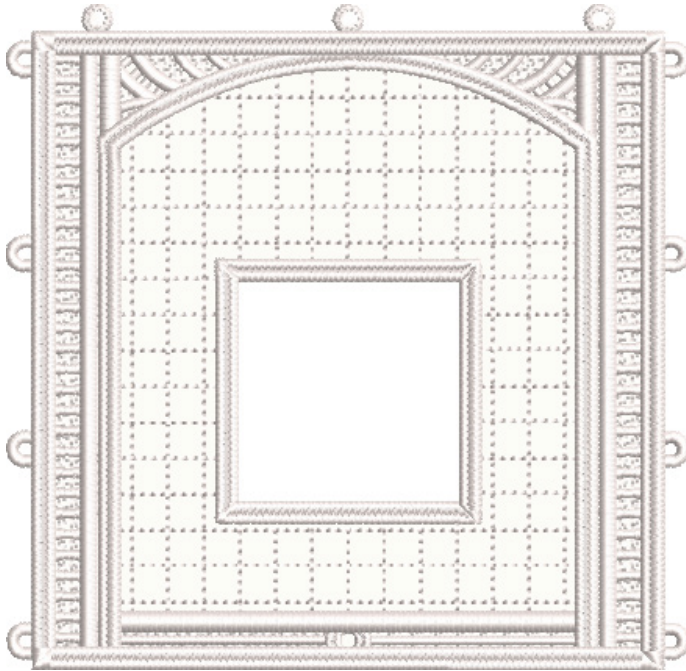

12845-04 Left & Right Inner Side Wall FSA

Size Inches: Size mm: Stitch Count:
5.00 X 5.12 in. 127.1 X 130.0 mm 30172 St.

- 1. White Fabric Placement Stitch 0015
- 2. Cut Line and Tackdown 0015
- 3. Lace and Cover Stitch 0015

***Fabric Required**

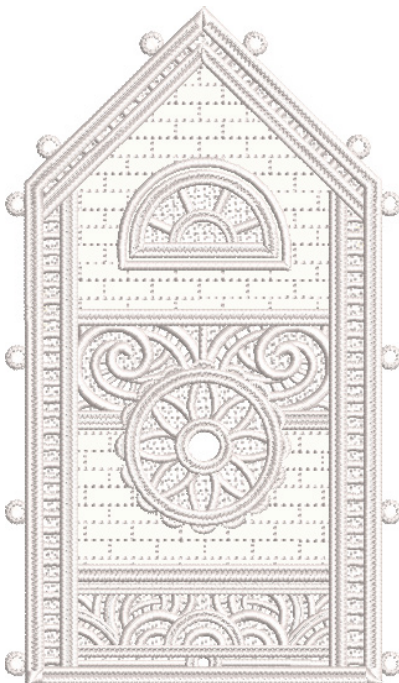

12845-05 Back Wall FSA

Size Inches: Size mm: Stitch Count:
6.45 X 3.74 in. 163.8 X 95.0 mm 44087 St.

- 1. White Fabric Placement Stitch 0015
- 2. Cut Line and Tackdown 0015
- 3. White Fabric Placement Stitch 0015
- 4. Cut Line and Tackdown 0015
- 5. Lace and Cover Stitch 0015

Note: Some designs in this collection may have been created using unique special stitches and/or techniques. To preserve design integrity when rescaling or rotating designs in your software, always rescale or rotate designs using the handles directly on-screen.

***Fabric Required**

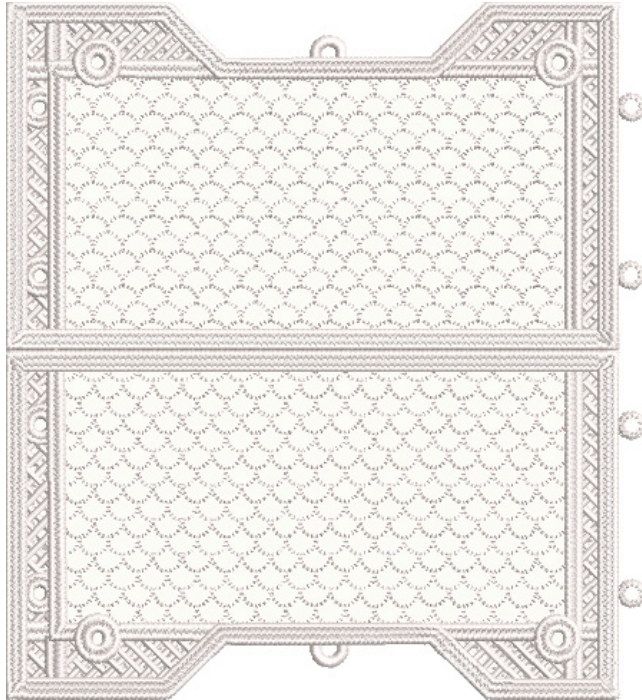

12845-06 Center Roof FSA

Size Inches: Size mm: Stitch Count:
5.71 X 5.21 in. 145.0 X 132.3 mm 57835 St.

- 1. Cream Fabric Placement Stitch..... 0015
- 2. Cut Line and Tackdown 0015
- 3. Cream Fabric Placement Stitch..... 0015
- 4. Cut Line and Tackdown 0015
- 5. Lace and Cover Stitch 0015

***Fabric Required**

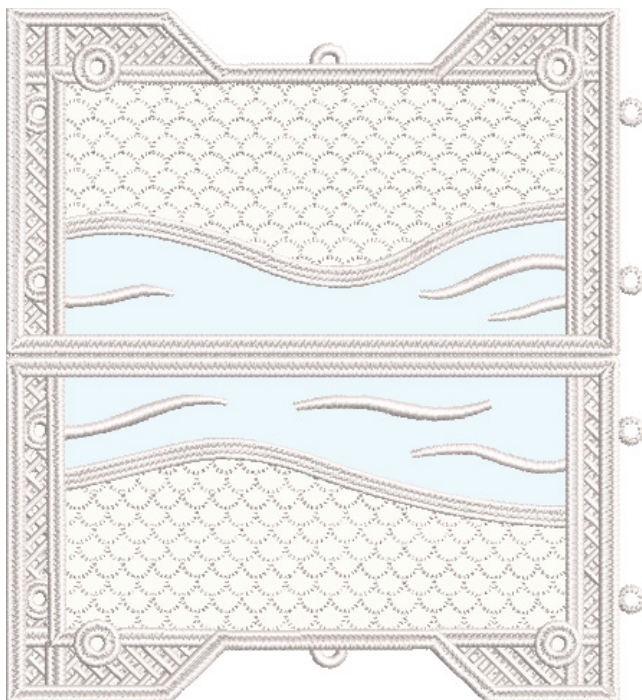

12845-07 Center Roof with Snow FSA

Size Inches: Size mm: Stitch Count:
5.69 X 5.19 in. 144.6 X 131.8 mm 53274 St.

- 1. Cream Fabric Placement Stitch..... 0015
- 2. Cut Line and Tackdown 0015
- 3. Cream Fabric Placement Stitch..... 0015
- 4. Cut Line and Tackdown 0015
- 5. White Fabric Placement Stitch 0015
- 6. Cut Line and Tackdown 0015
- 7. White Fabric Placement Stitch 0015
- 8. Cut Line and Tackdown 0015
- 9. Lace and Cover Stitch 0015

Note: Some designs in this collection may have been created using unique special stitches and/or techniques. To preserve design integrity when rescaling or rotating designs in your software, always rescale or rotate designs using the handles directly on-screen.

***Fabric Required**



12845-08 Right Side Wall FSA

Size Inches: Size mm: Stitch Count:
5.65 X 4.14 in. 143.5 X 105.2 mm 42351 St.

- 1. White Fabric Placement Stitch 0015
- 2. Cut Line and Tackdown 0015
- 3. White Fabric Placement Stitch 0015
- 4. Cut Line and Tackdown 0015
- 5. Lace and Cover Stitch 0015

***Fabric Required**



12845-09 Right Front Wall FSA

Size Inches: Size mm: Stitch Count:
4.01 X 2.73 in. 101.8 X 69.3 mm 23971 St.

- 1. White Fabric Placement Stitch 0015
- 2. Cut Line and Tackdown 0015
- 3. Lace and Cover Stitch 0015

Note: Some designs in this collection may have been created using unique special stitches and/or techniques. To preserve design integrity when rescaling or rotating designs in your software, always rescale or rotate designs using the handles directly on-screen.

***Fabric Required**

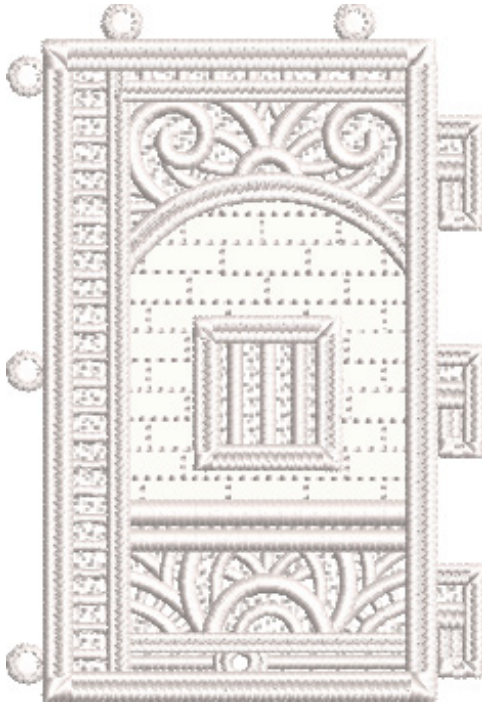

12845-10 Right Back Wall FSA

Size Inches: Size mm: Stitch Count:
4.01 X 2.73 in. 101.8 X 69.3 mm 22471 St.

- 1. White Fabric Placement Stitch 0015
- 2. Cut Line and Tackdown 0015
- 3. Lace and Cover Stitch 0015

***Fabric Required**



12845-11 Left Side Wall FSA

Size Inches: Size mm: Stitch Count:
5.65 X 4.14 in. 143.5 X 105.2 mm 42346 St.

- 1. White Fabric Placement Stitch 0015
- 2. Cut Line and Tackdown 0015
- 3. White Fabric Placement Stitch 0015
- 4. Cut Line and Tackdown 0015
- 5. Lace and Cover Stitch 0015

Note: Some designs in this collection may have been created using unique special stitches and/or techniques. To preserve design integrity when rescaling or rotating designs in your software, always rescale or rotate designs using the handles directly on-screen.

***Fabric Required**

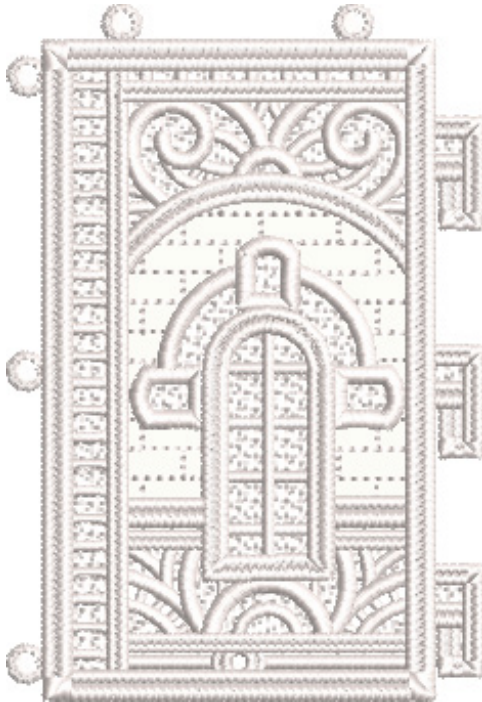

12845-12 Left Front Wall FSA

Size Inches: Size mm: Stitch Count:
4.01 X 2.74 in. 101.8 X 69.5 mm 23969 St.

- 1. White Fabric Placement Stitch 0015
- 2. Cut Line and Tackdown 0015
- 3. Lace and Cover Stitch 0015

***Fabric Required**

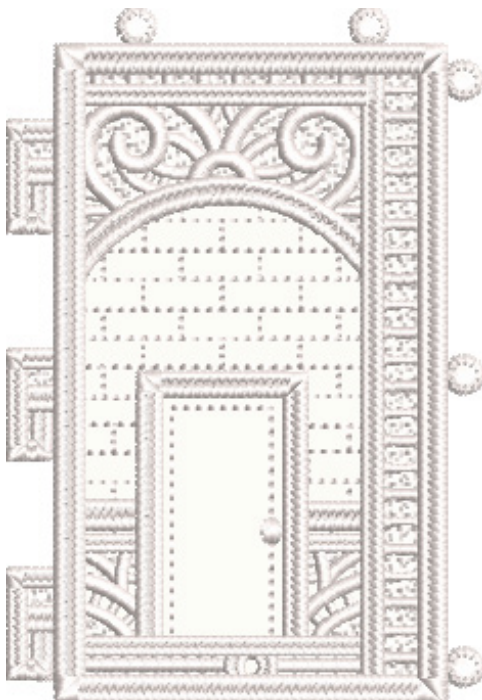

12845-13 Left Back Wall FSA

Size Inches: Size mm: Stitch Count:
4.01 X 2.73 in. 101.8 X 69.3 mm 21039 St.

- 1. White Fabric Placement Stitch 0015
- 2. Cut Line and Tackdown 0015
- 3. Cream Fabric Placement Stitch 0015
- 4. Cut Line and Tackdown 0015
- 5. Lace and Cover Stitch 0015

Note: Some designs in this collection may have been created using unique special stitches and/or techniques. To preserve design integrity when rescaling or rotating designs in your software, always rescale or rotate designs using the handles directly on-screen.

***Fabric Required**

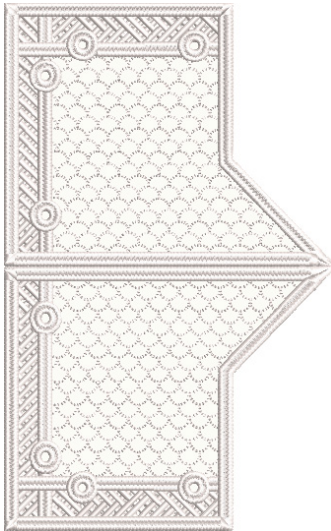

12845-14 Left & Right Side Roof FSA

Size Inches: Size mm: Stitch Count:
6.30 X 3.92 in. 160.1 X 99.5 mm 40680 St.

- 1. Cream Fabric Placement Stitch..... 0015
- 2. Cut Line and Tackdown 0015
- 3. Cream Fabric Placement Stitch..... 0015
- 4. Cut Line and Tackdown 0015
- 5. Lace and Cover Stitch 0015

***Fabric Required**

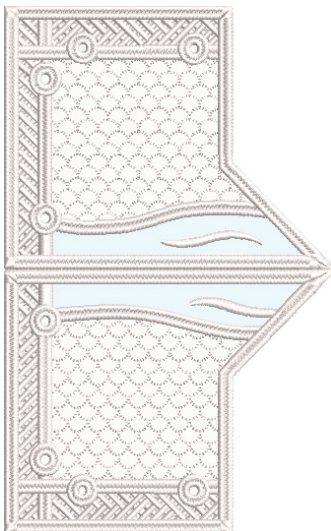

12845-15 Left & Right Side Roof with Snow FSA

Size Inches: Size mm: Stitch Count:
6.30 X 3.92 in. 160.1 X 99.5 mm 40426 St.

- 1. Cream Fabric Placement Stitch..... 0015
- 2. Cut Line and Tackdown 0015
- 3. Cream Fabric Placement Stitch..... 0015
- 4. Cut Line and Tackdown 0015
- 5. White Fabric Placement Stitch 0015
- 6. Cut Line and Tackdown 0015
- 7. White Fabric Placement Stitch 0015
- 8. Cut Line and Tackdown 0015
- 9. Lace and Cover Stitch 0015

Note: Some designs in this collection may have been created using unique special stitches and/or techniques. To preserve design integrity when rescaling or rotating designs in your software, always rescale or rotate designs using the handles directly on-screen.

***Fabric Required**

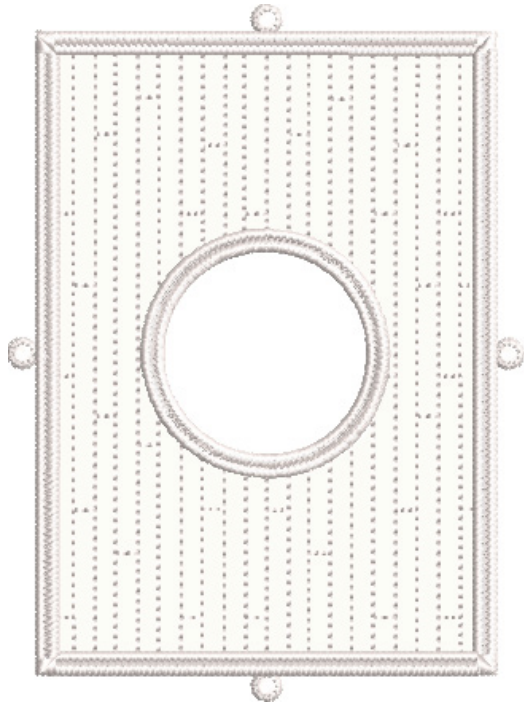

12845-16 Center Foundation FSA

Size Inches: Size mm: Stitch Count:
5.14 X 3.79 in. 130.5 X 96.3 mm 11044 St.

- 1. Cream Fabric Placement Stitch..... 0015
- 2. Cut Line and Tackdown 0015
- 3. Lace and Cover Stitch 0015

***Fabric Required**

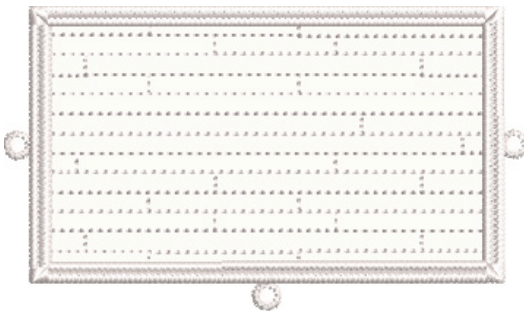

12845-17 Side Foundations FSA

Size Inches: Size mm: Stitch Count:
5.59 X 4.19 in. 142.1 X 106.3 mm 12632 St.

- 1. Cream Fabric Placement Stitch..... 0015
- 2. Cut Line and Tackdown 0015
- 3. Cream Fabric Placement Stitch..... 0015
- 4. Cut Line and Tackdown 0015
- 5. Lace and Cover Stitch 0015

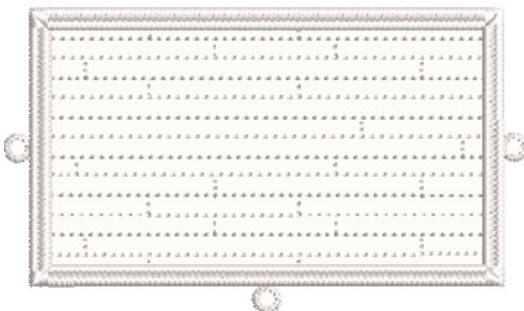

Stabilizers

- OESD AquaMesh WashAway
- OESD BadgeMaster WashAway
- OESD StabilStick CutAway

Fabrics/Textiles

White Version

- 1/8 yard Cream
- 1/4 yard White
- Note: Fabric sizes are estimates and may result in overage.

Color Version

- 1/8 yard Dark Blue
- 1/4 yard Light Blue

Notions & Tools

- OESD Alligator Clamps
- OESD Button Clips
- OESD Perfect Embroidery Press Cloth
- OESD Expert Embroidery Tape WashAway
- OESD Expert Point and Press Tool
- Embroidery Needle Sharp 75/11

Isacord Thread Colors

White Version

- 0015 White (3 spools)

Color Version

- 0105 Ash Mist (3 spools)

SUMMARY



Completed Size: 7" H x 9" W x 6" D

12845-01



Requires 1 Design

12845-02

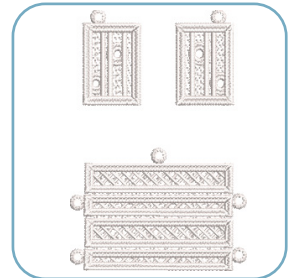

Requires 1 Design

12845-03

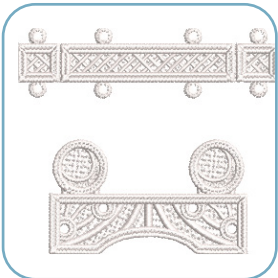

Requires 1 Design

12845-04

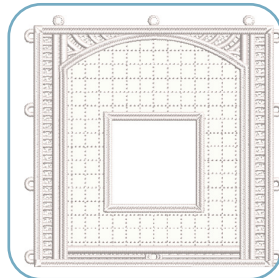

Requires 2 Designs

12845-05

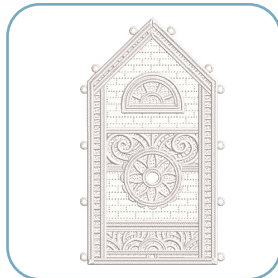

Requires 1 Design

12845-06 or 12845-07

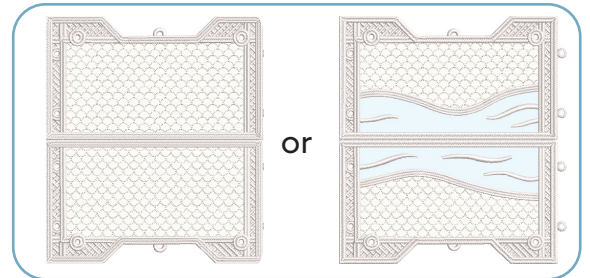

Requires 1 Design

12845-08



Requires 1 Design

12845-09

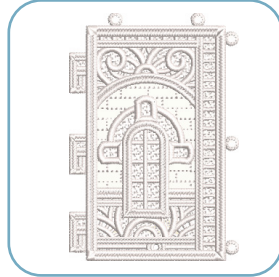

Requires 1 Design

12845-10

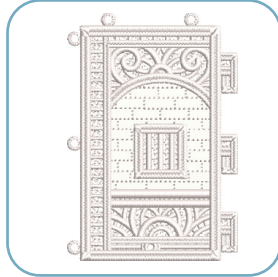

Requires 1 Design

12845-11

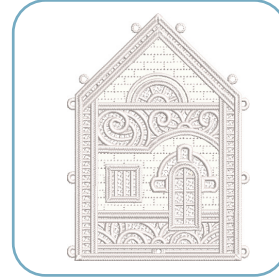

Requires 1 Design

12845-12

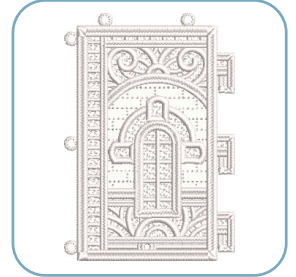

Requires 1 Design

12845-13

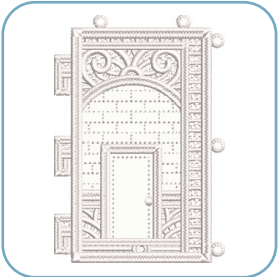

Requires 1 Design

12845-14 or 12845-15

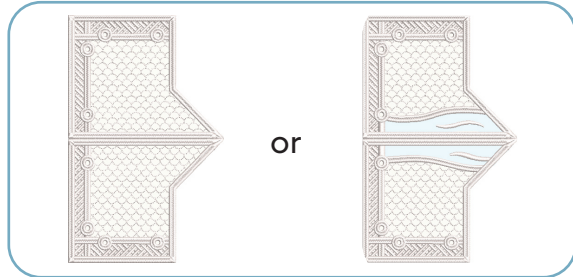

Requires 2 Designs

12845-16

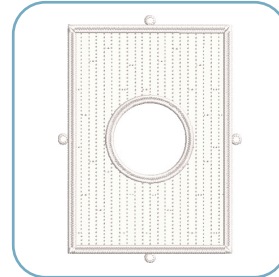

Requires 1 Design

12845-17

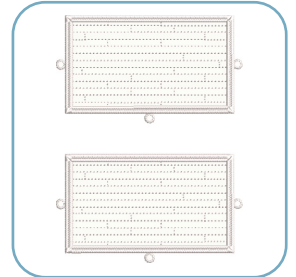

Requires 1 Design

PREPARATION



NOTES

The freestanding applique instructions, included in the collection, are general instructions. For demonstration purposes, a sample design that best demonstrates the technique is shown. Fabric and thread requirements will vary by design, but the general technique is the same.

All designs are stitched with matching thread, top and bobbin.

For other designs in the collection, use the applique templates as a guide to the dimensions of the various applique pieces.

Note: Some thread colors in instructions have been changed or digitally enhanced for better visibility.

STEP 1

- Hoop one layer of OESD AquaMesh and one layer of OESD BadgeMaster for all designs.



STEP 2

- Adhere two layers of StabilStick CutAway to the wrong side of all applique fabrics, to provide stiffness to the finished structure.



STEP 3

- Load selected design into the machine.
- • Example design is Front Wall FSA (12845-01).
- • Thread the machine per the thread chart.
- • Place hoop on the machine.
- • Stitch Machine Step 1, White Fabric Placement Stitch.

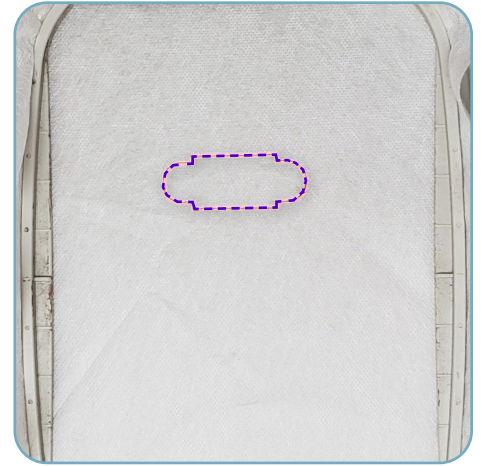

STEP 4

- Remove the hoop from the machine, but NOT the project from the hoop.
- Place the hoop on a flat surface.
- Cut the prepared applique fabrics 1/4" -1/2" larger than the applique templates.
- Completely cover the placement stitch with the prepared fabric.
- Tape in place to secure.



STEP 5

- Return the hoop to the machine.
- Stitch Machine Step 2, Cut Line and Tackdown.



EMBROIDERY



STEP 6

- Remove the hoop from the machine, but NOT the project from the hoop.
- Trim the excess fabric as close to the cut line stitching as possible. If the outermost stitches are cut, the inner stitches will hold the applique in place.
- Tip: If the AquaMesh is cut or a hole is created while trimming the fabric, use OESD Expert Embroidery Tape WashAway as a patch.



STEP 7

- Return the hoop to the machine.
- Continue stitching Machine Steps 3-8, stopping after Machine Step 8.
- Note: On the Door applique, shown in dark blue, use a craft knife to cut through all layers removing the fabric and stabilizer from the windows. Cover the openings with a layer of Expert Embroidery Tape WashAway to stitch the remaining embroidery.

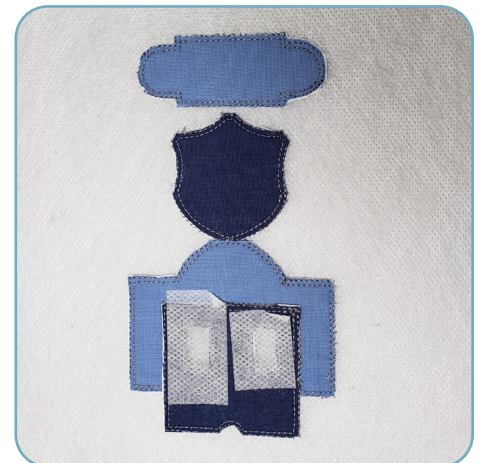

STEP 8

- Stitch Machine Step 9, Lace and Cover Stitch.
- When design is complete, remove the project from the hoop and trim the stabilizer 1/4" - 1/2" outside the design.



ASSEMBLY



STEP 9

- Rinse each piece in warm running water until the design is only slightly tacky.
- Place right side down on a non-stick surface to dry. Parchment paper or a cooling rack work well to prevent curling. Dry completely.
- Press each piece, right side down, on a Perfect Embroidery Press Cloth.



STEP 11

- Bend the Front Steps FSL (12845-02) as shown. With an iron, press the creases in the steps.

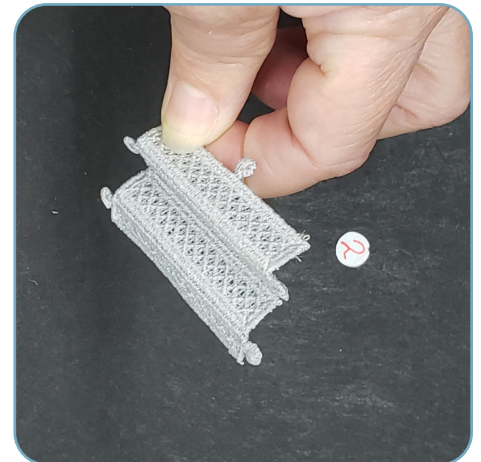

ASSEMBLY



STEP 12

- Match the eyelets and buttonettes. Attach the two side stair pieces (12845-02) to the side of the steps by pulling each buttonette through the corresponding eyelet.



STEP 13

- Attach Front Stair unit (12845-02) to Front Wall FSA (12845-01) as indicated.

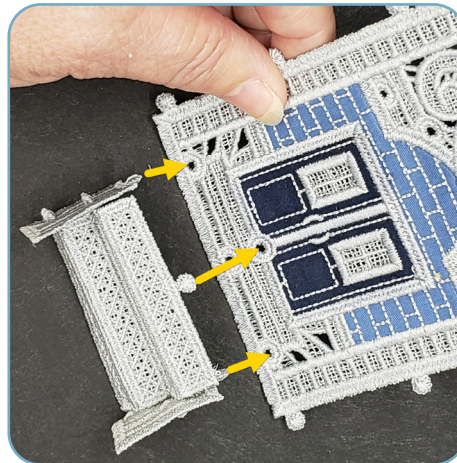

STEP 14

- Bend the brace section of the Front Lamps FSL (12845-03) toward the center.

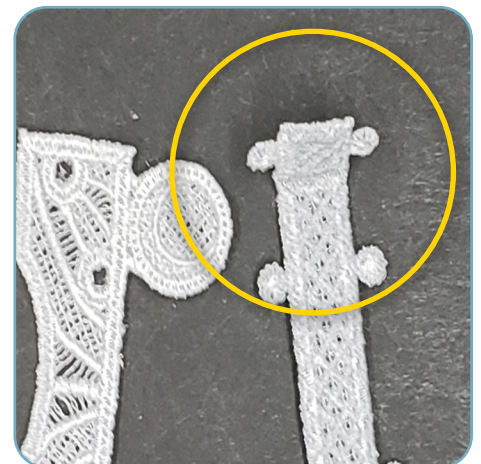

ASSEMBLY



STEP 15

- Attach the lamps to the brace as shown.

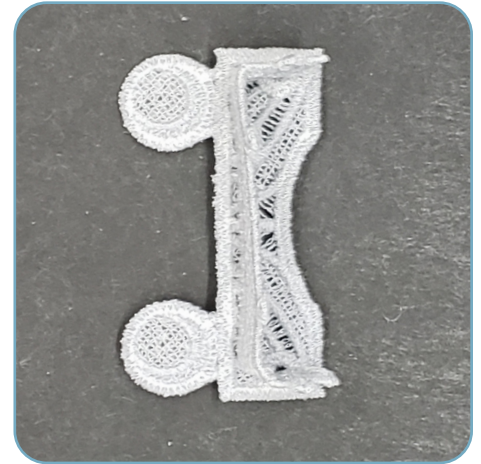
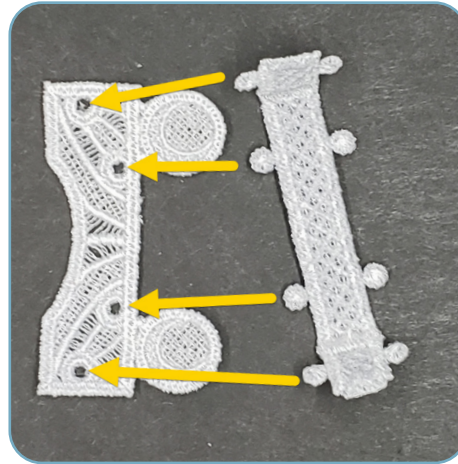

STEP 16

- Attach the Front Lamps (12845-03) unit to the Front Wall (12845-01).



STEP 17

- Attach the two Inner Side Walls FSA (12845-04) to the Front Wall FSA (12845-01) by pulling the buttonettes through the corresponding eyelets as shown.



ASSEMBLY



STEP 18

- Attach the Back Wall FSA (12845-05) to the two Center Walls FSA (12845-04).



STEP 19

- Attach the Center Roof FSA (12845-06 or 12845-07 with snow) to the center structure.
- Attach a button clip to hold the eyelet in place temporarily when needed.



STEP 20

- With the Right Side Wall FSA (12845-08) in the center, line up the Right Front Wall FSA (12845-09) and the Right Back Wall FSA (12845-10) on either side with buttonettes next to the eyelets as shown.
- Attach the front and back pieces to the side by pulling the buttonettes through the corresponding eyelets. Set aside.



ASSEMBLY



STEP 21

- With the Left Side Wall FSA (12845-11) in the center, line up the Left Front Wall FSA (12845-12) and the Left Back Wall FSA (12845-13) on either side with buttonettes next to the eyelets as shown.
- Attach the front and back pieces to the side by pulling the buttonettes through the corresponding eyelets. Set aside.



STEP 22

- Attach a Side Roof FSA (12845-15 or 12845-16 with snow) to each side structure by pulling the buttonettes on the front, side and back through the corresponding eyelets in the roof as shown.



STEP 23

- Attach a Side Foundation FSA (12845-17) to each side structure by pulling the three floor buttonettes through the corresponding eyelets on the front, side and back of each side.

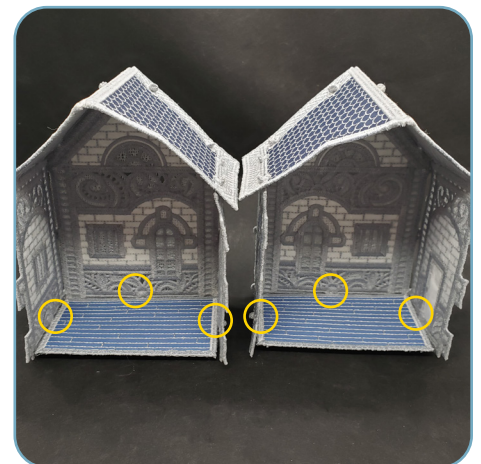

ASSEMBLY



STEP 24

- Insert the tabs on the front and back walls of the side structures into the corresponding slots on the sides of the center structure. Alligator Clamps may be inserted through the tab entry from the inside of the center section to assist in pulling the tabs through.



STEP 25

- Once the tabs are pulled through, slide the sides down to be even with the bottom of the center section.
- Note: After putting the tabs into the tab entries, twist them slightly to help them stay in place, or use Button Clips to temporarily hold them.

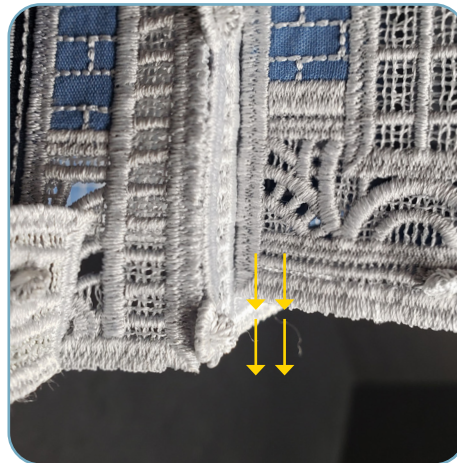

STEP 26

- Attach the Center Foundation FSA (12845-16) to the center section by inserting the tab on each side through the corresponding eyelet on each side.

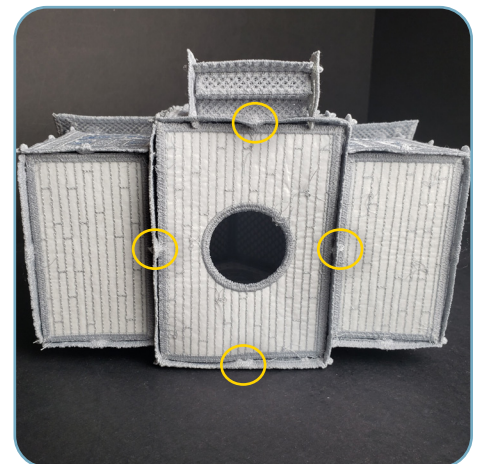

FINISHING TOUCHES

- The police station is complete. Enjoy.
- Add tea lights or pixie lights to create a glow.



General Freestanding Lace Guide



Stabilizer

- OESD AquaMesh
- OESD BadgeMaster

Notions/Tools

- 80/12 Embroidery Ballpoint Titanium needle for extended needle life
- OESD Alligator Clamps
- OESD Button Clips
- OESD Perfect Point and Press Tool

Isacord Thread Colors

- All OESD designs are digitized with Isacord 40 wt. polyester thread as the top thread and in the bobbin.
- Refer to the thread chart for color specifications.
- Match bobbin thread color to the top thread.

Instructions

Step 1 - Hoop

For FSL structures, hoop one layer of OESD AquaMesh and one layer of OESD BadgeMaster. BadgeMaster contains more starch so, combined with the AquaMesh, the lace is more rigid. For other FSL, where a softer lace is desired, hoop two layers of AquaMesh.

Step 2 - Embroider

Stitch the design per the thread chart with matching thread in the bobbin at each color change. When complete, remove from the hoop and trim away excess stabilizer about 1/4"-1/2" from the stitching.

Step 3 - Rinse

Rinse remaining stabilizer out in warm running water. For stiffer lace and FSL structures, DO NOT rinse away all of the stabilizer. The lace should be just slightly tacky. For softer lace, rinse until all traces of the stabilizer are removed.

Step 4 - Dry

Lay right side down flat on a non-stick surface, such as a cooling rack, parchment paper or Teflon sheet. This minimizes the tendency for the lace to curl. Let the pieces dry completely before proceeding with any assembly.

Step 5 - Press

Once completely dry, press right side down on a OESD Perfect Embroidery Press Cloth.

Step 6 - Assemble Structure

Note: Specific assembly instructions for a design/collection may be found in the thread chart pdf following the individual design color charts.

Lace must be COMPLETELY DRY before assembly. Wetting the buttonettes or eyelets to assemble is not recommended and may result in them stretching and coming "unbuttoned" when dry.

Use a pair of OESD Alligator Clamps to insert the buttonettes into the eyelets. Insert the tip of the OESD Alligator Clamps into the eyelet, grasp the buttonette and pull through the eyelet. Alternatively, use a stiletto or tweezers to push the buttonette through the eyelet.

Helpful Tips

Limp Lace

If the design is not stiff enough, press the lace pieces on the wrong side while applying spray starch. After ironing, spray again with starch and allow to dry completely. This will stiffen the lace pieces nicely and aid in construction. Or easily re-stiffen by diluting some stabilizer scraps in water (or use liquid starch) and dipping the item in the solution. Lay flat to dry.

Eyelets Too Small

If any of the eyelets appear closed or too small to penetrate with Alligator Clamps, they may be stretched by inserting the small end of the OESD Perfect Point and Press Tool into the eyelet opening and stretching it open wide enough to accommodate the OESD Alligator Clamps.

Button Clips

During the assembly process, some structures pull on buttonettes that have already been inserted and could pull them out altogether. Putting a Button Clip on the assembled buttonette will keep it in position during the assembly process. Remove the Button Clips when the assembly is complete.

Alternative Construction Option

In some cases, the buttonettes may be pulled to the inside of a project, instead of being visible on the outside. Insert the OESD Alligator Clamps through the eyelet from the wrong, or inside, of the lace and grasp the corresponding buttonette. Pull the buttonette to the wrong side of the lace.

Pulling the buttonettes to the inside may cause stress on the ones already done. Button clips may be placed on the completed buttonette(s) to prevent them from pulling out of the eyelet during construction.

ATTENTION

When printing this document, any page scaling or page fitting options in your print dialog box must be turned OFF or set to NONE so that your files will print out at their actual size. Images not printed at actual size will not function as intended.

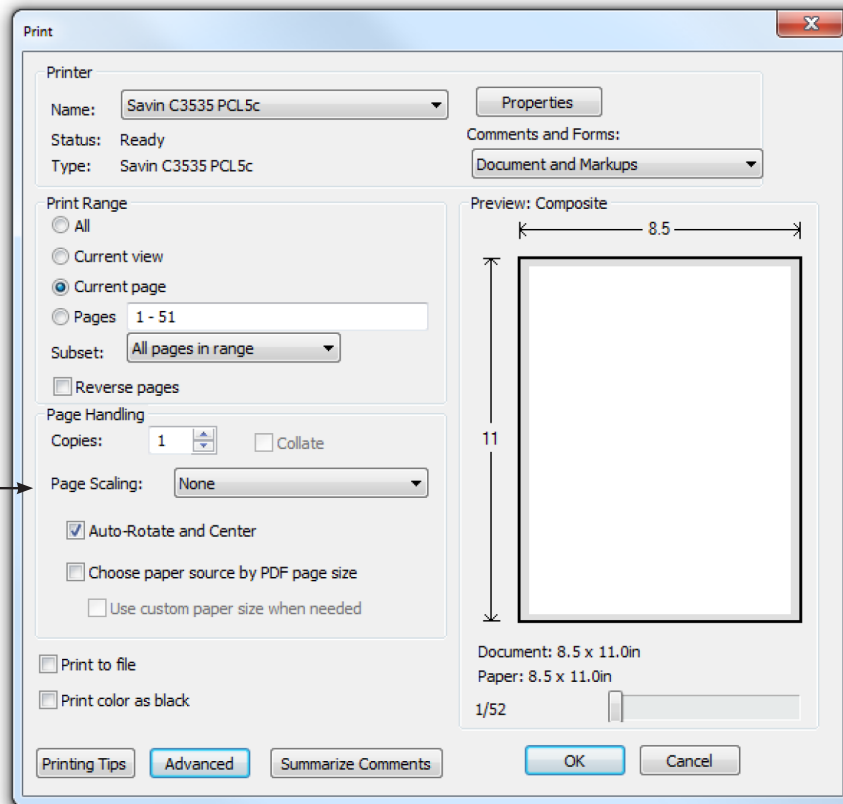

TO SAVE PAPER

Only print the desired image by navigating to the image's page, go to File > Print and select "Current page" in the print dialog box. Repeat for each desired image.

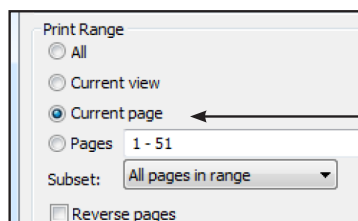

APPLIQUE PATTERNS



Print at 100%. No scaling. This box measures 1" x 1". Use the box as an accuracy guide when printing templates.

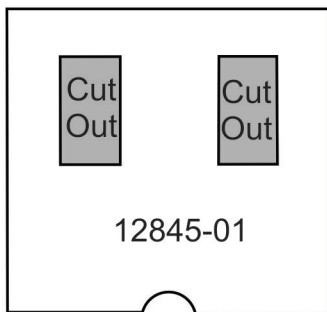
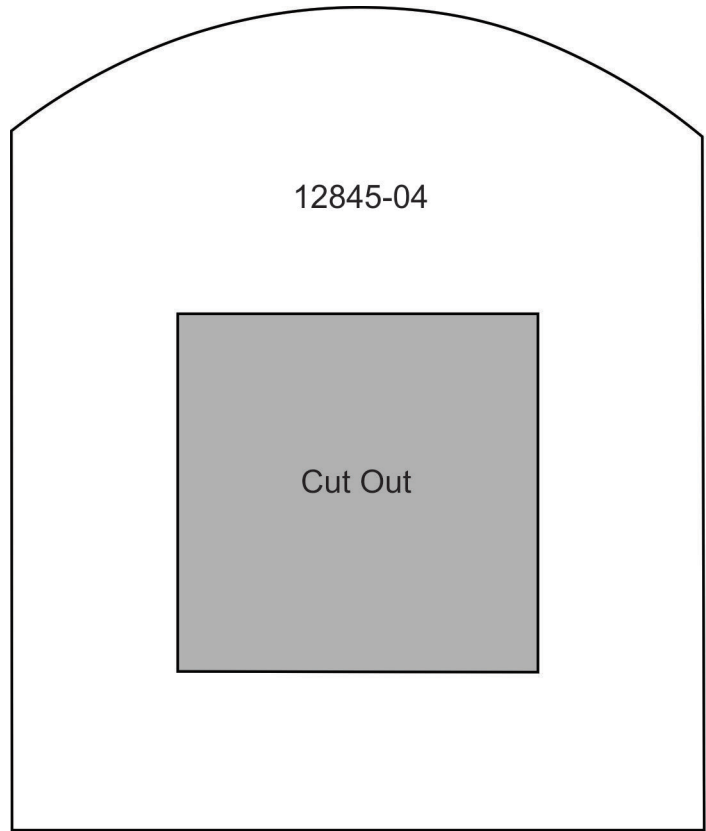
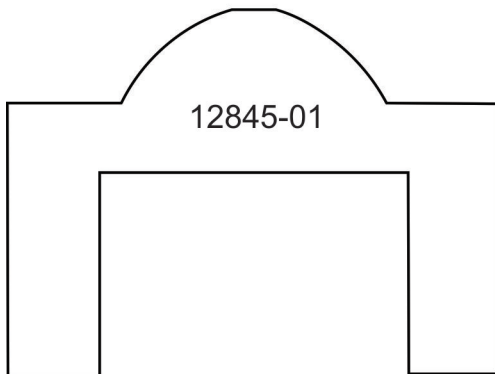
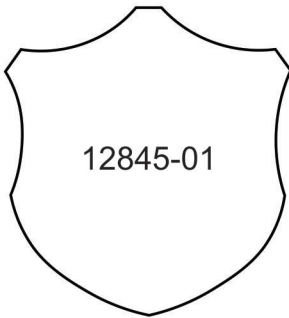
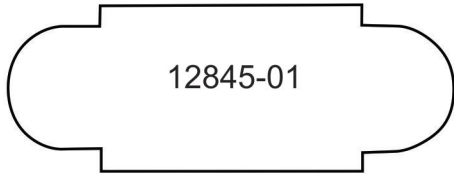

APPLIQUE PATTERNS



Print at 100%. No scaling. This box measures 1" x 1". Use the box as an accuracy guide when printing templates.

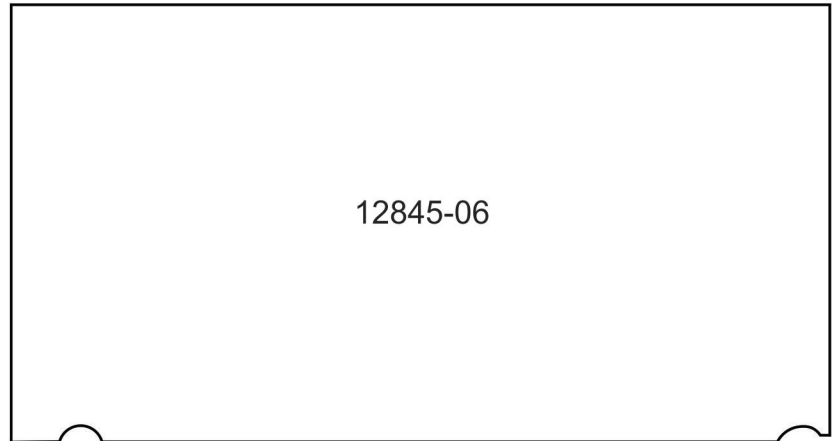
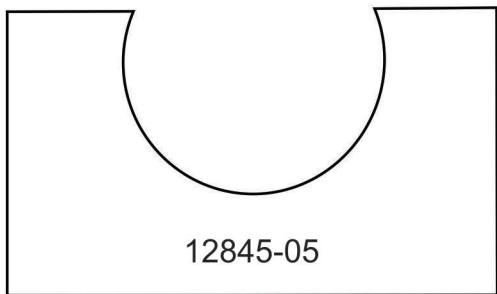
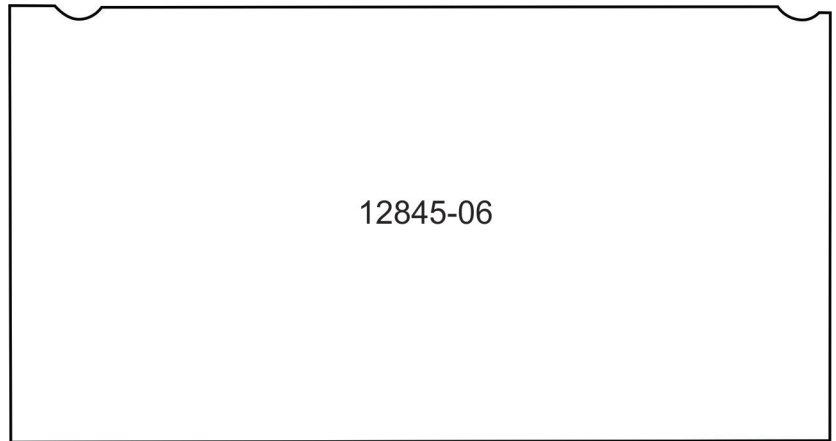
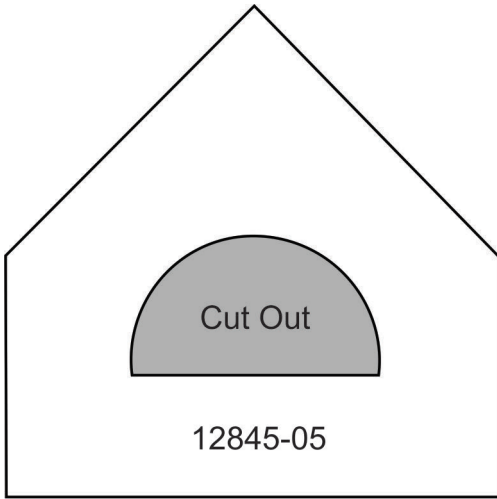

APPLIQUE PATTERNS



Print at 100%. No scaling. This box measures 1" x 1". Use the box as an accuracy guide when printing templates.

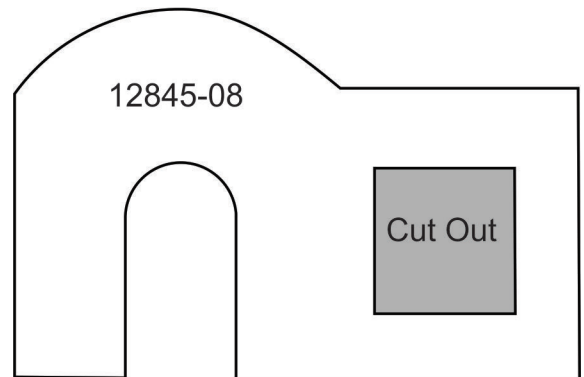
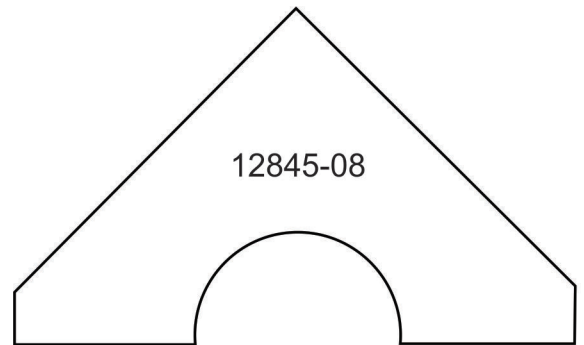
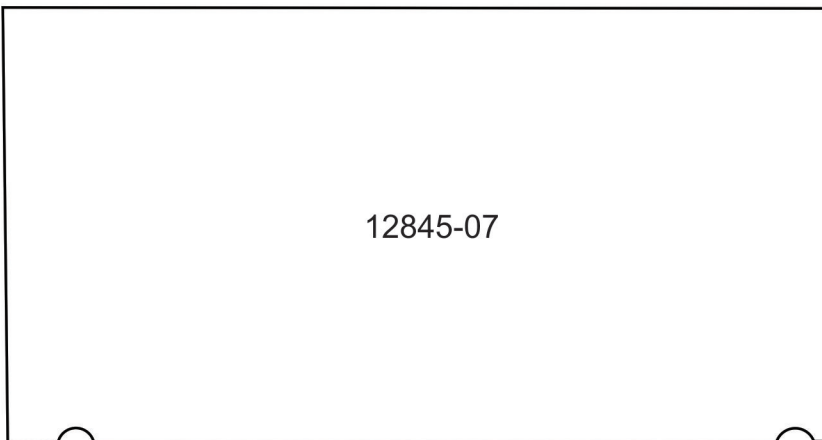
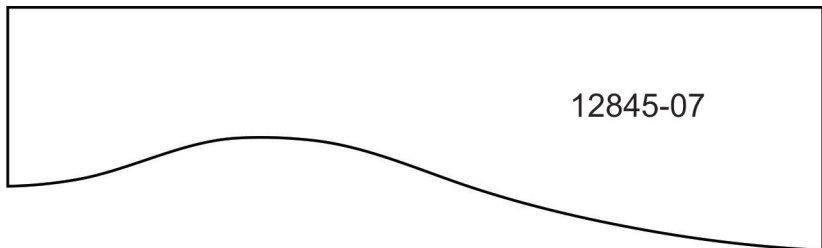
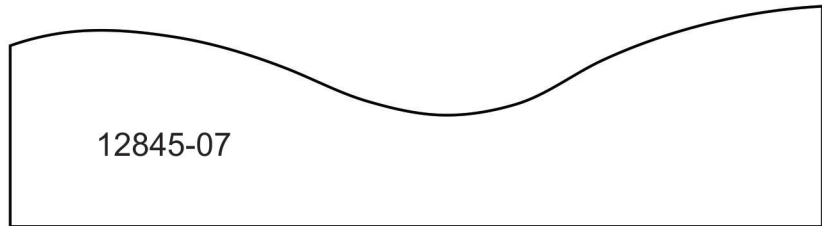
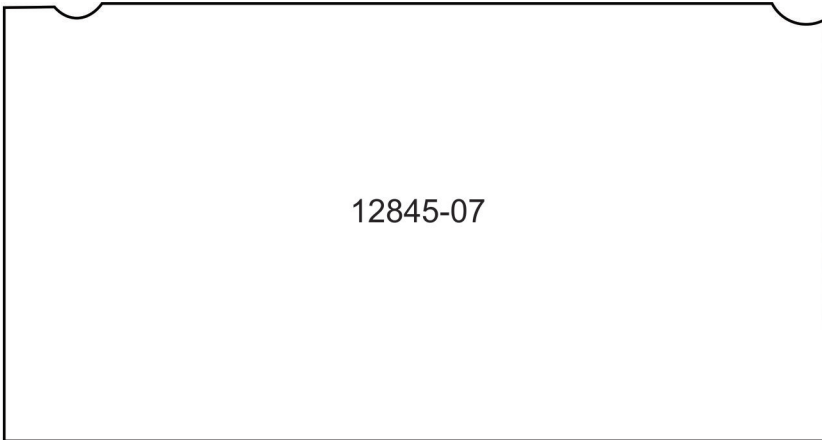

APPLIQUE PATTERNS



Print at 100%. No scaling. This box measures 1" x 1". Use the box as an accuracy guide when printing templates.

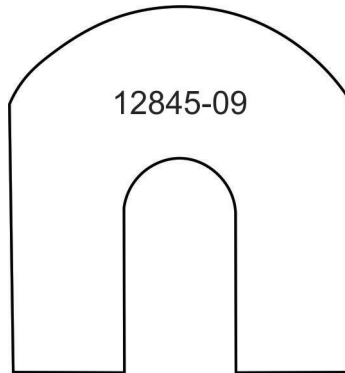

12845-09

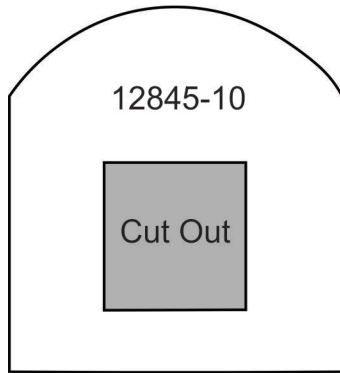

12845-10

Cut Out

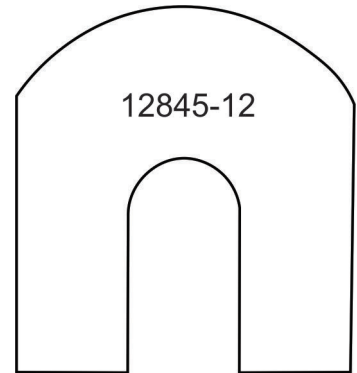

12845-12

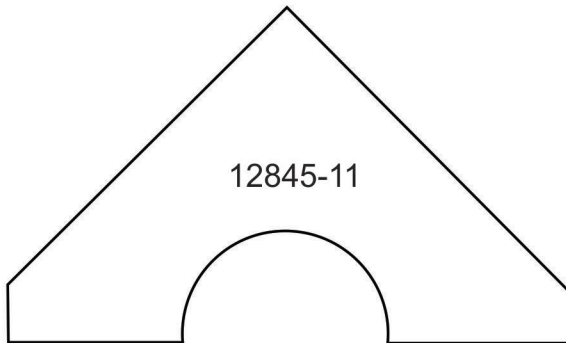

12845-11

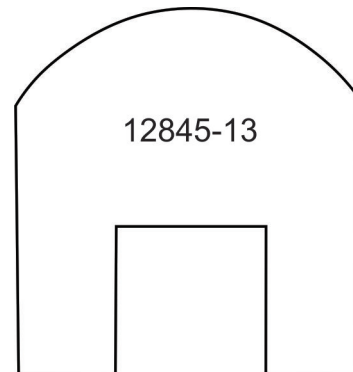

12845-13

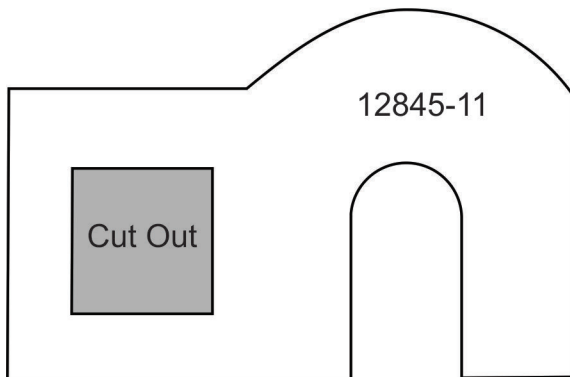

12845-11

Cut Out

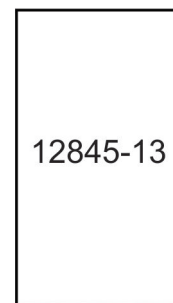

12845-13

APPLIQUE PATTERNS



Print at 100%. No scaling. This box measures 1" x 1". Use the box as an accuracy guide when printing templates.

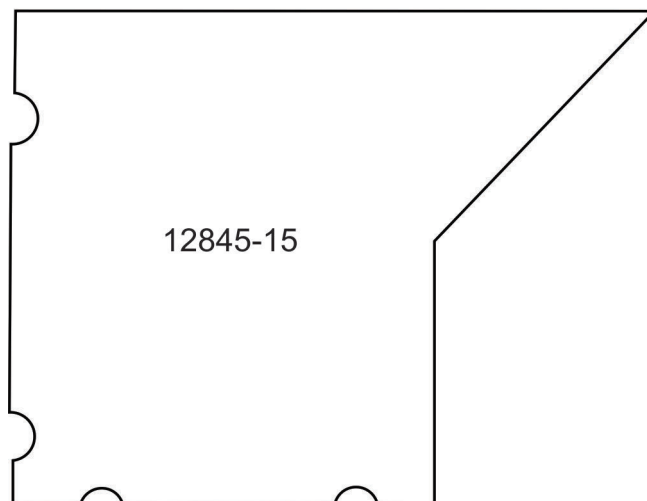
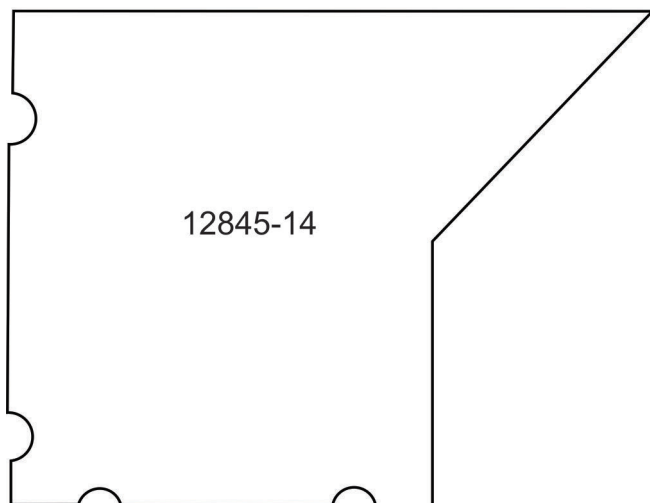
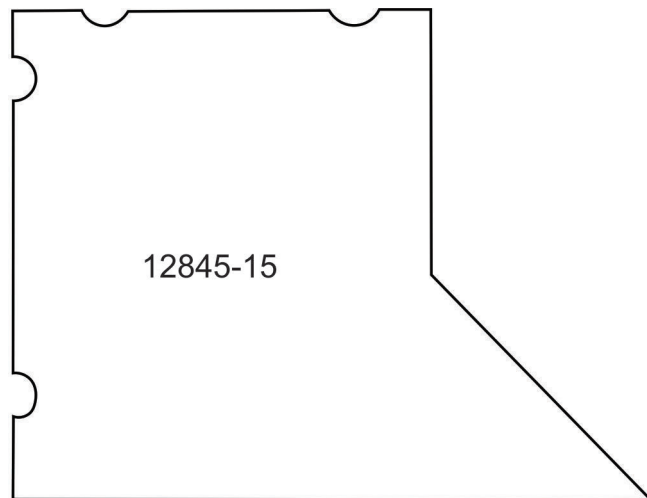
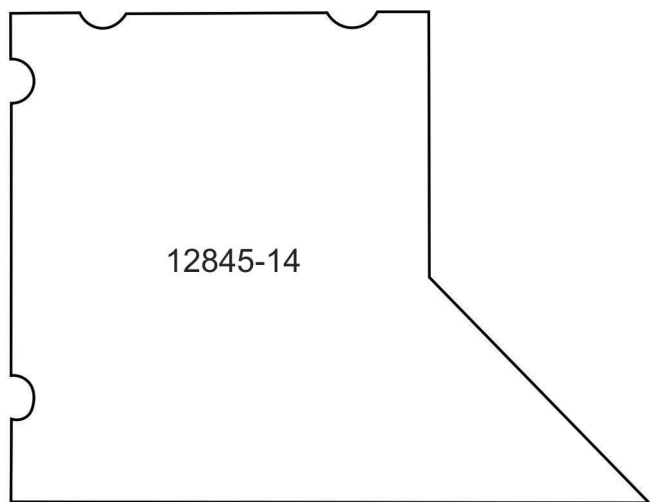

APPLIQUE PATTERNS



Print at 100%. No scaling. This box measures 1" x 1". Use the box as an accuracy guide when printing templates.

12845-16

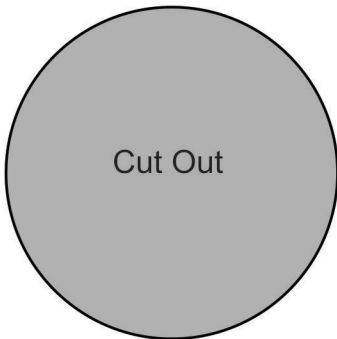

Cut Out

12845-17

12845-17

MIRRORED PATTERNS



Print at 100%. No scaling. This box measures 1" x 1". Use the box as an accuracy guide when printing templates.

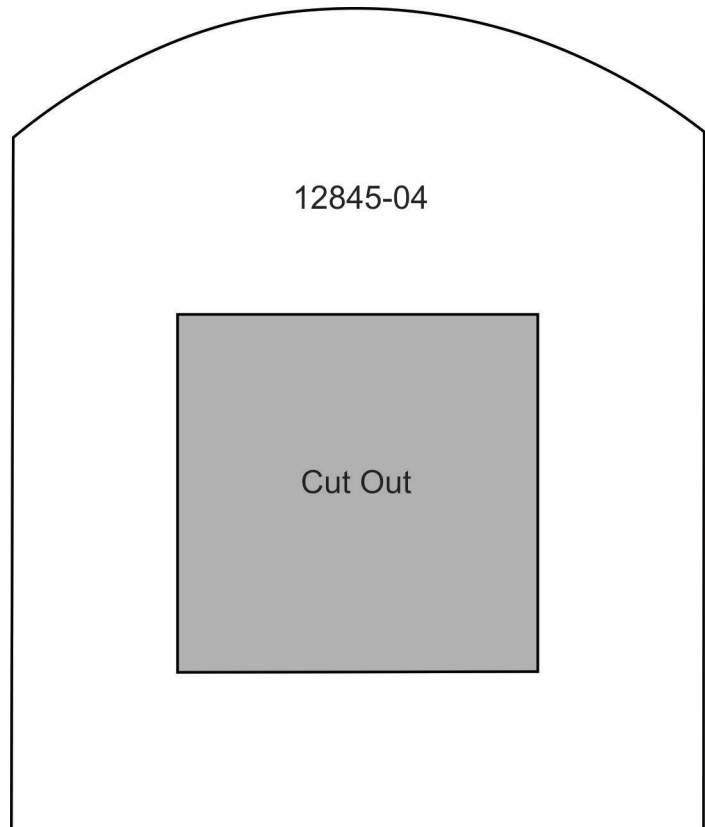
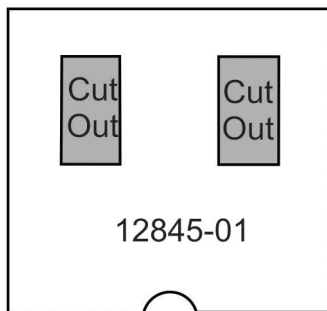
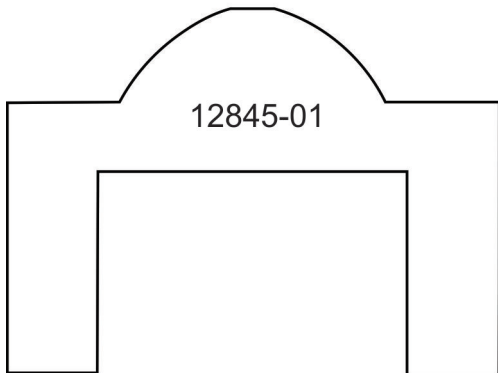
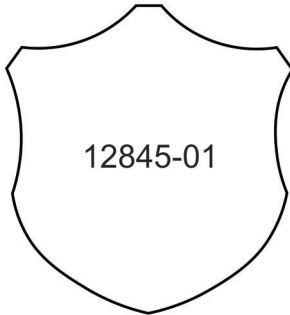
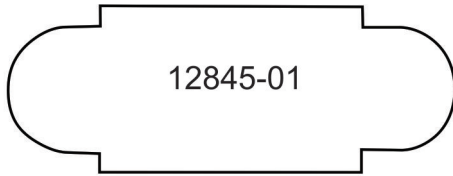

MIRRORED PATTERNS



Print at 100%. No scaling. This box measures 1" x 1". Use the box as an accuracy guide when printing templates.

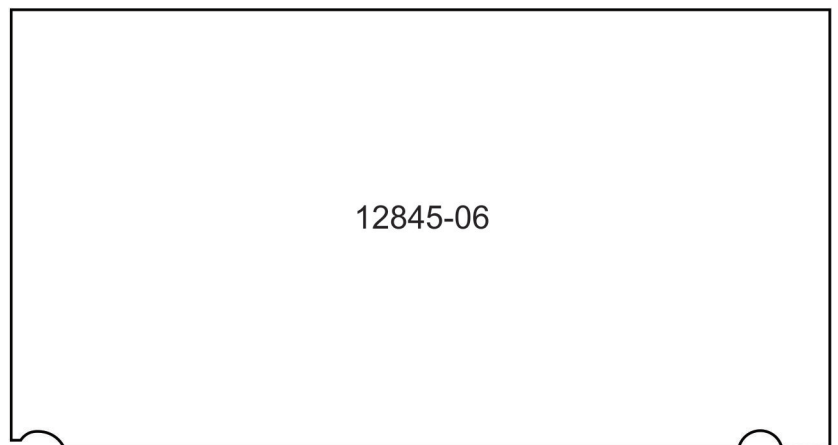
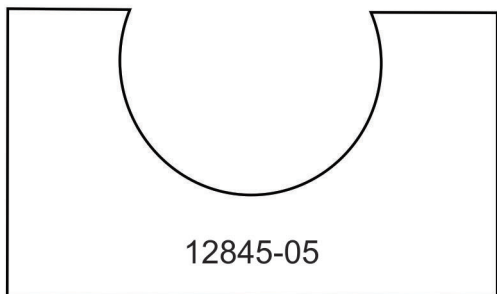
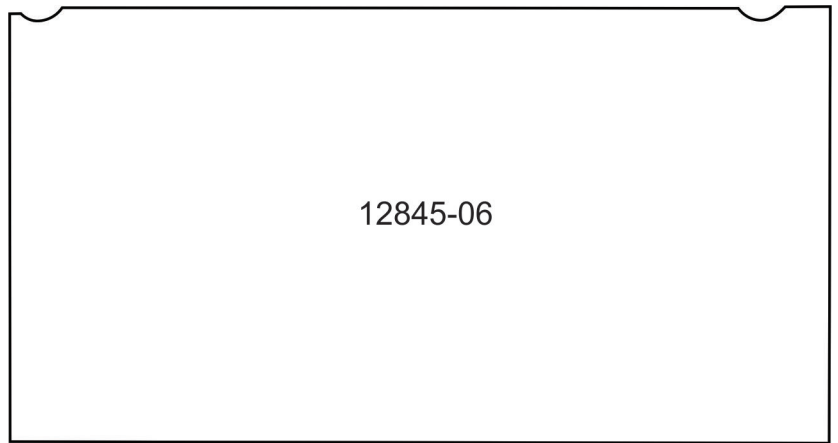
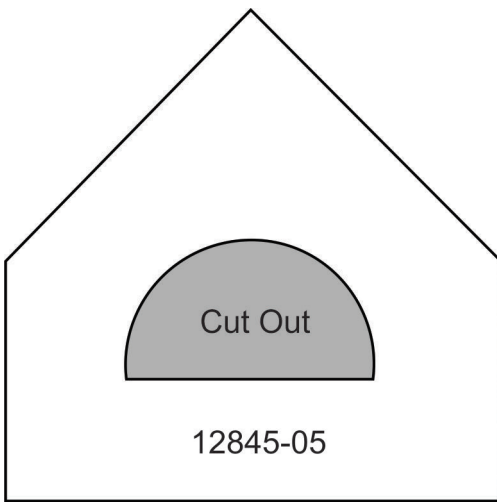

MIRRORED PATTERNS



Print at 100%. No scaling. This box measures 1" x 1". Use the box as an accuracy guide when printing templates.

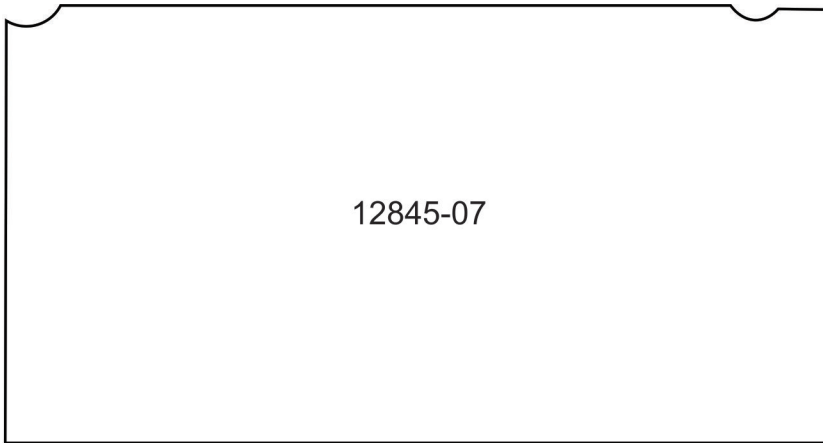

12845-07

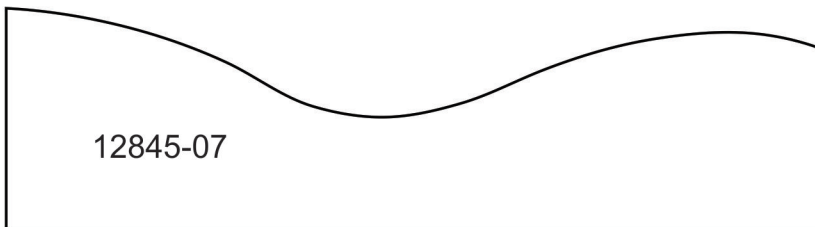

12845-07

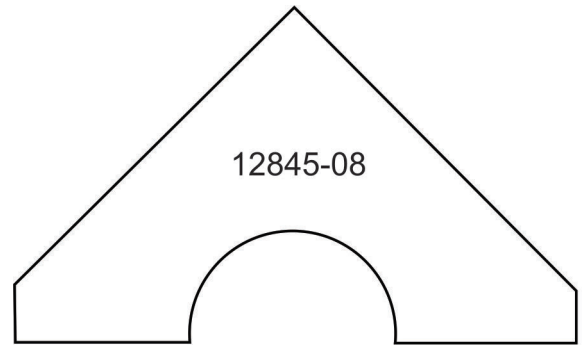

12845-08

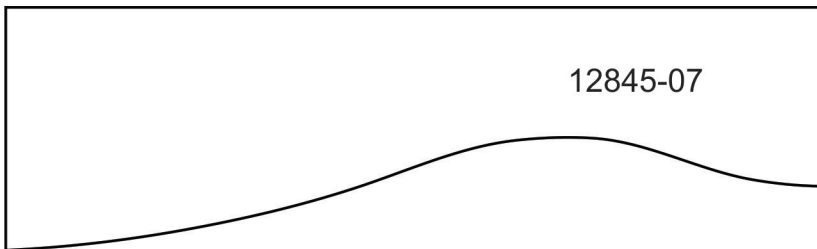

12845-07

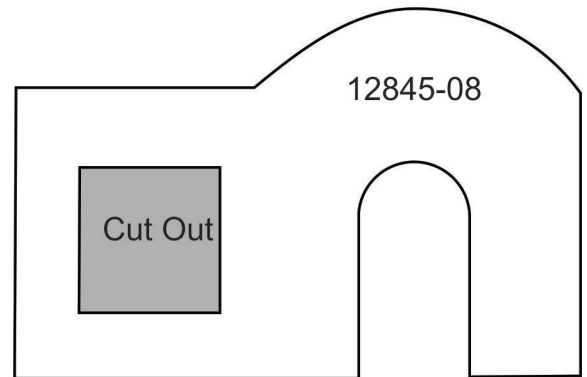

12845-08

Cut Out

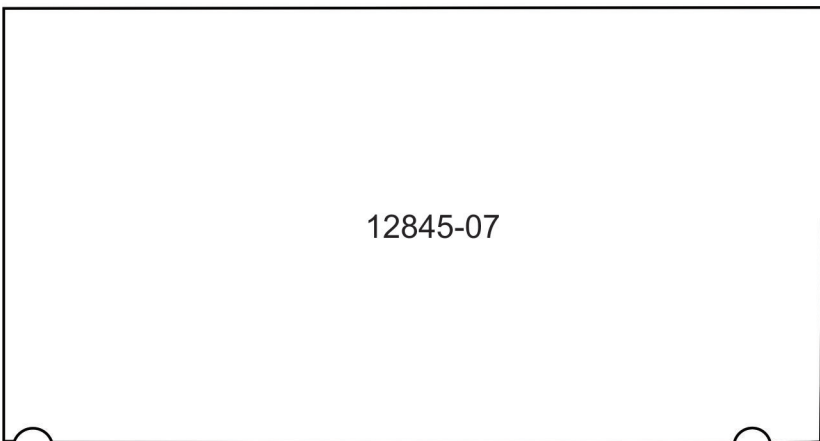

12845-07

MIRRORED PATTERNS



Print at 100%. No scaling. This box measures 1" x 1". Use the box as an accuracy guide when printing templates.

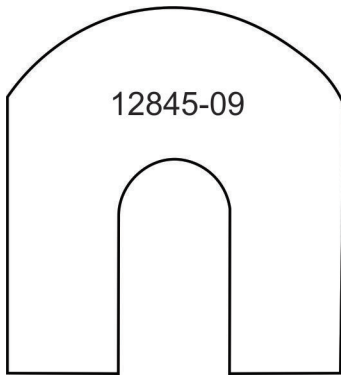

12845-09

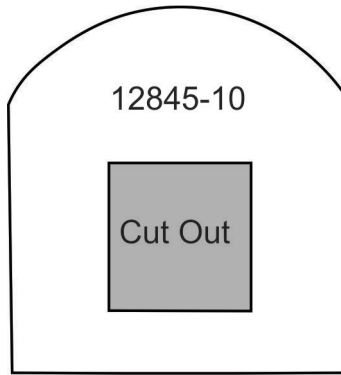

12845-10

Cut Out

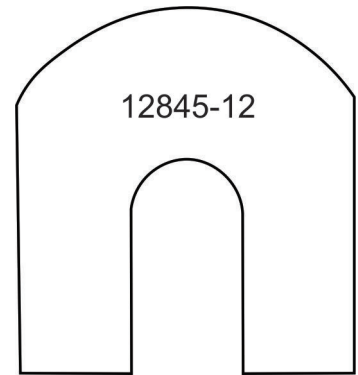

12845-12

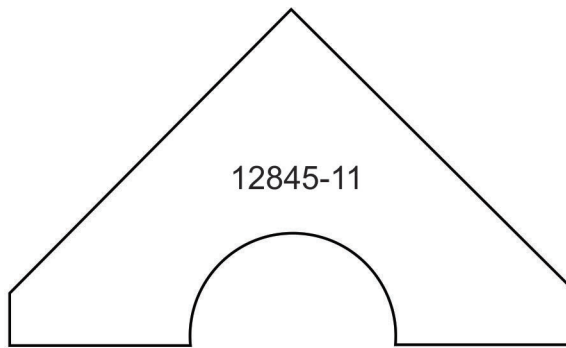

12845-11

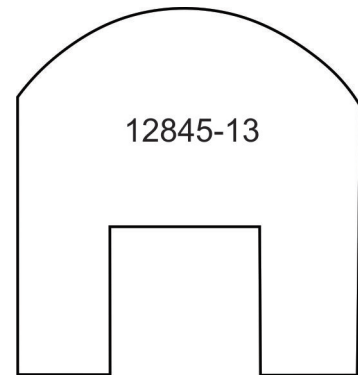

12845-13

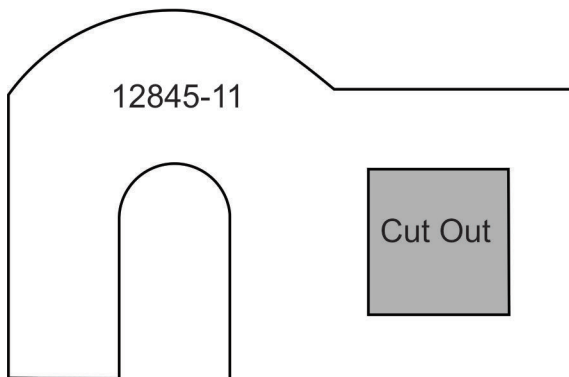

12845-11

Cut Out

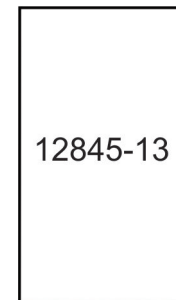

12845-13

MIRRORED PATTERNS



Print at 100%. No scaling. This box measures 1" x 1". Use the box as an accuracy guide when printing templates.

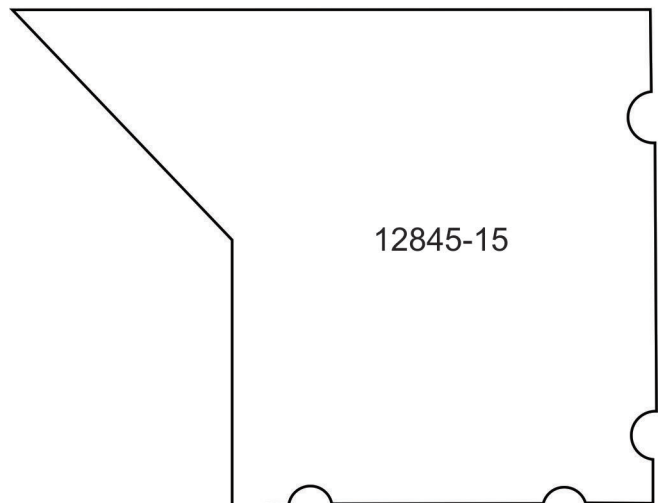
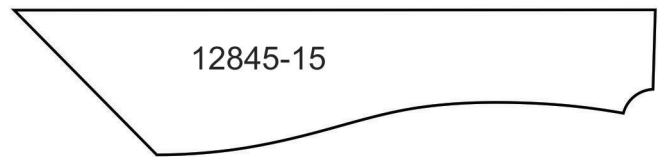
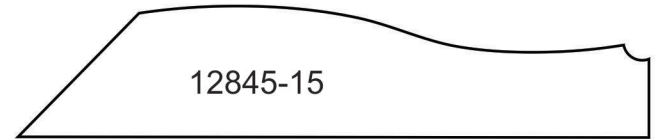
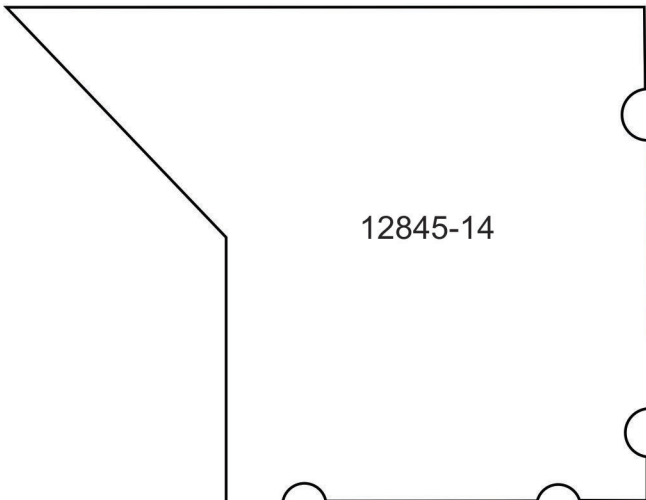
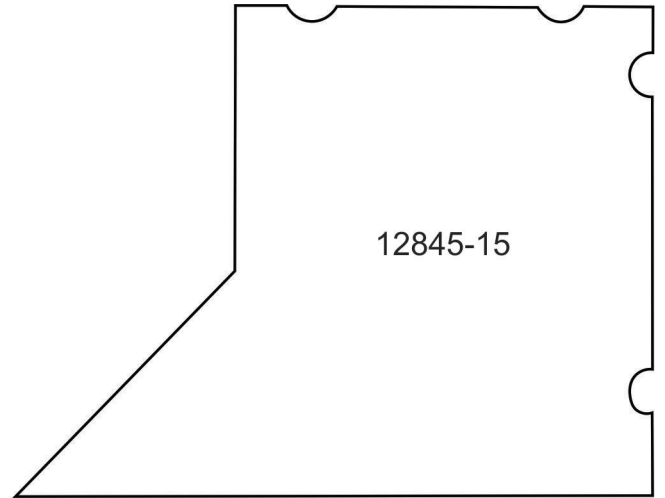
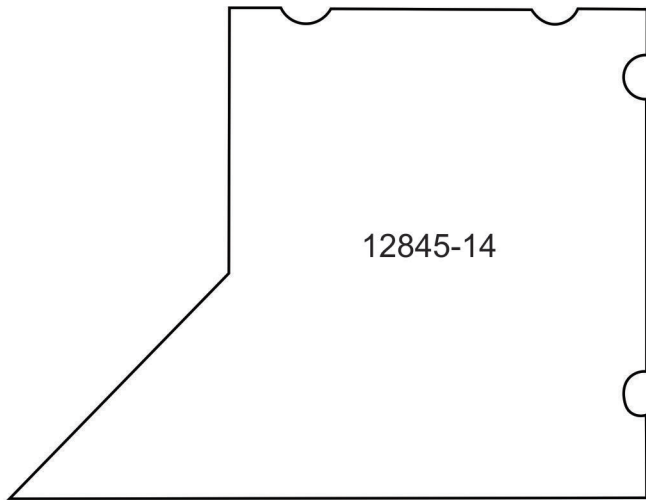

MIRRORED PATTERNS



Print at 100%. No scaling. This box measures 1" x 1". Use the box as an accuracy guide when printing templates.

12845-16

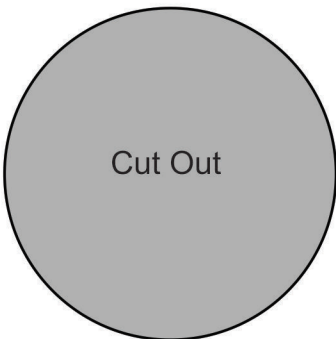

Cut Out

12845-17

12845-17