

# ALL AGLOW FREESTANDING CHRISTMAS TREE



**1**

**Design**

# THREAD LIST

## Isacord Thread Colors

---

0101 Eggshell  
0532 Champagne

**Note: One spool of 1000 meter thread is adequate for the project unless otherwise noted.**

## Stabilizers

- OESD AquaMesh WashAway
- OESD BadgeMaster WashAway
- OESD StabilStick CutAway
- OESD Fiber Form
- OESD Applique Fuse and Fix

## Fabrics/Textiles

- OESD Luxe Sparkle Vinyl – White (2 rolls)

## Notions & Tools

- OESD Alligator Clamps
- OESD Button Clips
- OESD Expert Embroidery Tape TearAway
- OESD Expert Embroidery Tape WashAway
- OESD Perfect Punch Tool
- OESD MiniMAT
- OESD Perfect Embroidery Press Cloth
- OESD Grippy GRID
- Embroidery Needle Sharp 75/11 (FSA)
- Embroidery Needle Ballpoint 80/12 (FSL)

## Isacord Thread Colors

- Per the thread chart
- Match bobbin thread to top thread

# SUMMARY



Completed Size: 11 1/2" H x 6 1/4" W x 6 1/4" D

12954-01



Requires 1 Design

12954-02

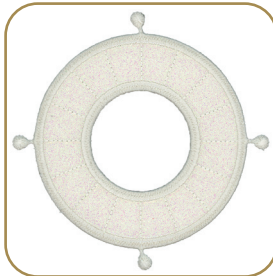

Requires 1 Design

12954-03

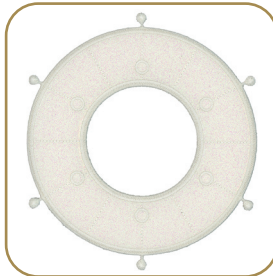

Requires 1 Design

12954-04

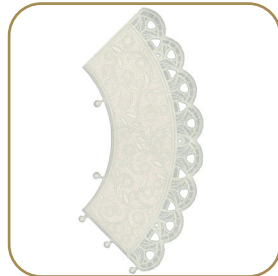

Requires 1 Design

12954-05

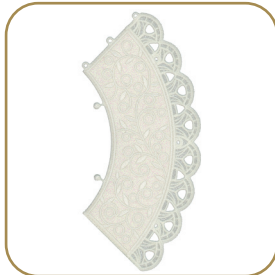

Requires 1 Design

12954-06

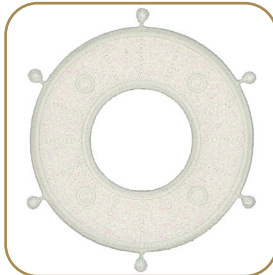

Requires 1 Design

12954-07



Requires 1 Design

12954-08



Requires 1 Design

12954-09

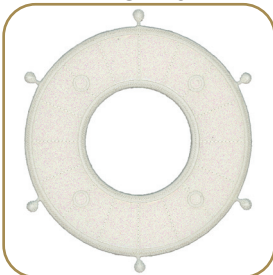

Requires 1 Design

12954-10



Requires 1 Design

12954-11

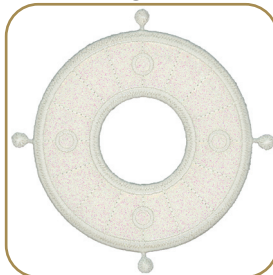

Requires 1 Design

12954-12

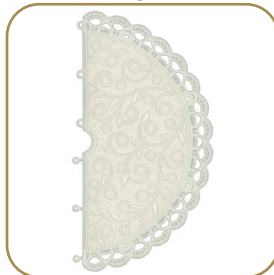

Requires 1 Design

12954-13



Requires 1 Design

## Notes

The freestanding applique instructions, included in the collection, are general instructions. For demonstration purposes, a sample design that best demonstrates the technique is shown. Fabric and thread requirements will vary by design, but the general technique is the same. All designs are stitched with matching thread, top and bobbin.

**Note:** Some thread colors in instructions have been changed or digitally enhanced for better visibility.

## STEP 1

- Print the mirrored version of the templates (at 100% scale or 1:1 ratio) onto the paper side of Applique Fuse and Fix.
- Cut approximately  $\frac{1}{4}$ " -  $\frac{1}{2}$ " outside the printed applique templates.

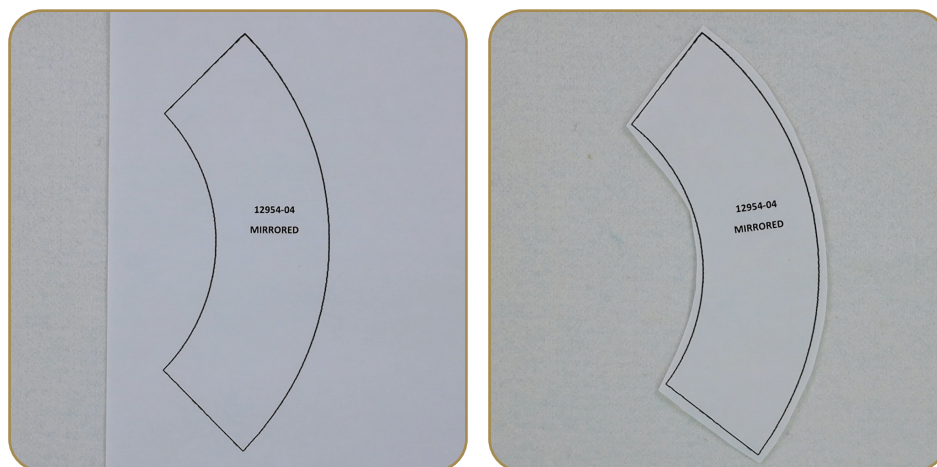

## STEP 2

- Cut the Fiber Form 1/4" -1/2" larger than the applique templates.
- Fuse the trimmed templates to the back of the Fiber Form with the paper side of the printed template up. Hold the iron on the template for 10-15 seconds for a secure fuse.

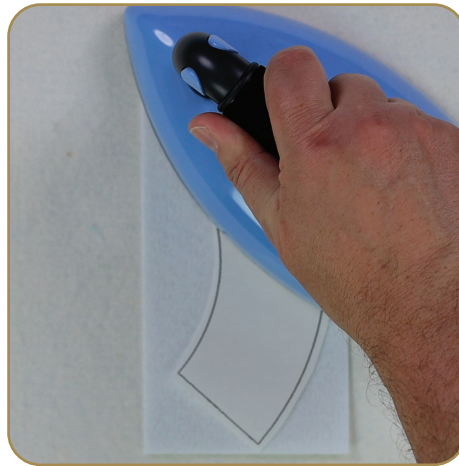
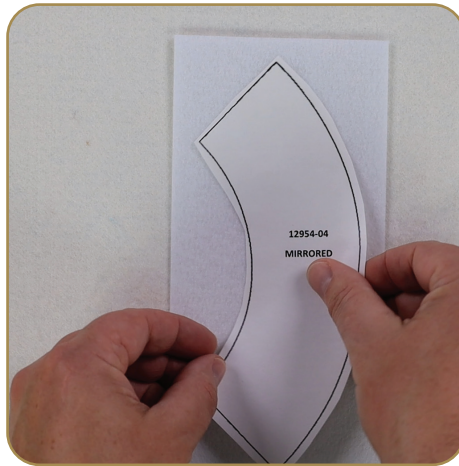

## STEP 3

- Trim the Fiber Form on the edge of the black outline.
- Set aside.

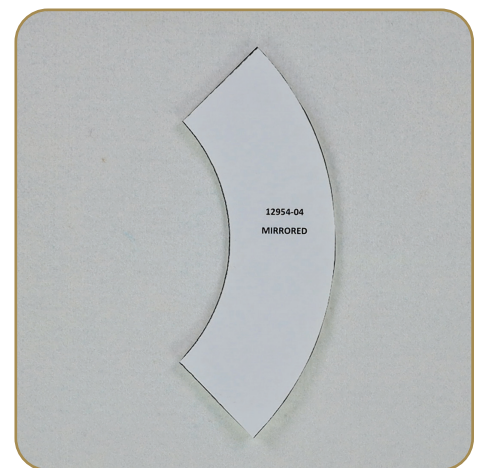

## STEP 4

- Adhere one layer of StabilStick CutAway to the wrong side of all applique vinyl, to provide stiffness to the finished structure.
- Cut the prepared applique vinyl 1/4"-1/2" larger than the templates that are included at the end of the instructions.

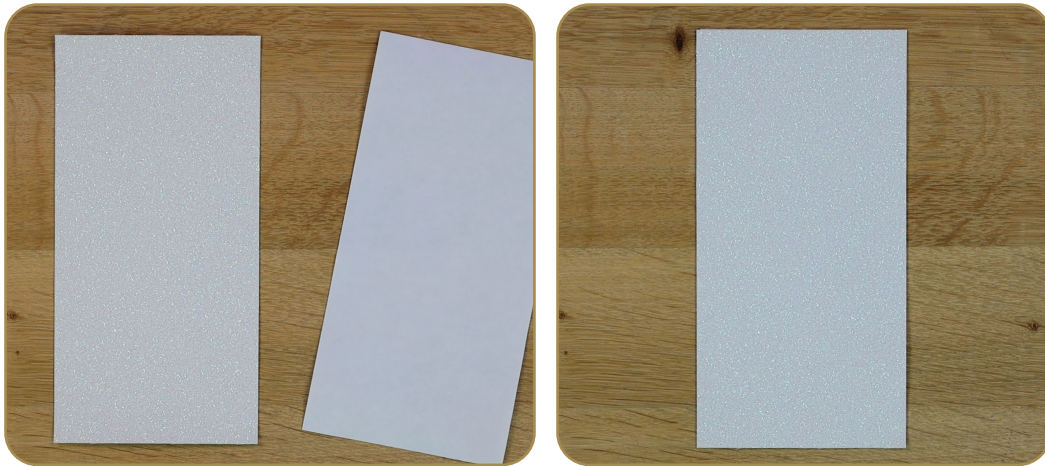

## STEP 5

- Hoop one layer of AquaMesh and one layer of BadgeMaster for all designs.

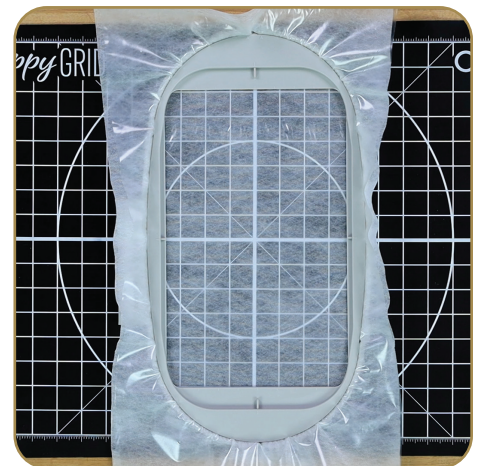

## STEP 6

- Load selected design into the machine.
- Example design is 12954-04.
- Thread the machine per the thread chart.
- Place the hoop on the machine.
- Stitch Machine Step 1, Fiber Form and White Vinyl Placement Stitch.

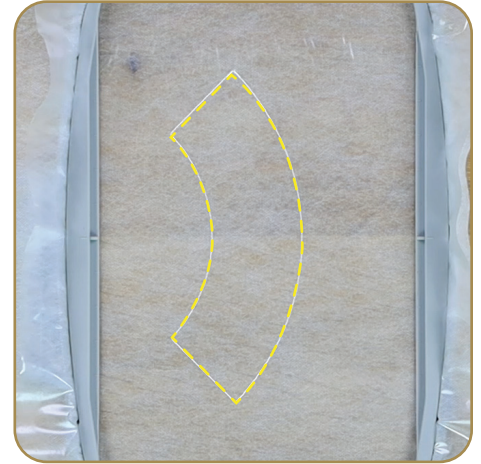

## STEP 7

- Remove the hoop from the machine, but NOT the project from the hoop.
- Place the hoop on a flat surface.
- On the back of the Fiber Form, score and remove the paper backing to reveal the adhesive surface.
- Place the Fiber Form within the placement stitching.
- Finger press to secure.

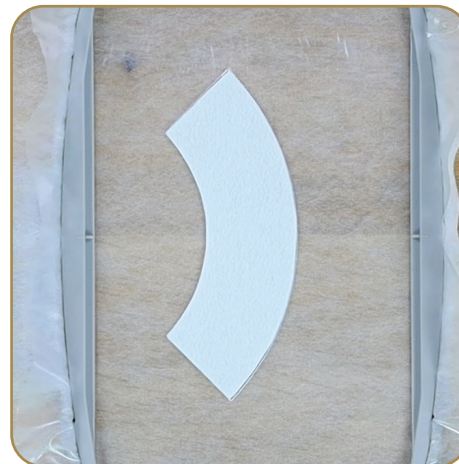



# EMBROIDERY

## STEP 8

- Completely cover the Fiber Form and the placement stitch with the prepared vinyl.
- Tape in place to secure.



## STEP 9

- Return the hoop to the machine.
- Stitch Machine Step 2, Cut Line and Tackdown.

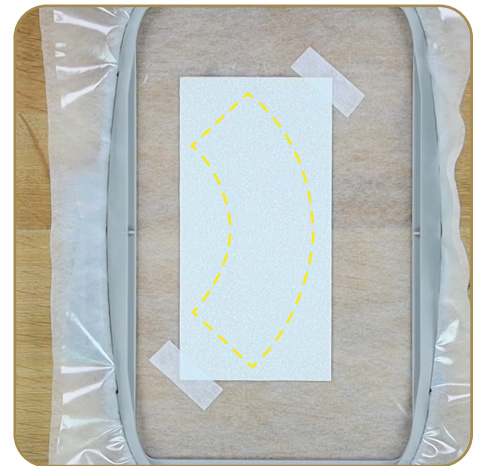

## STEP 10

- Remove the hoop from the machine, but NOT the project from the hoop.
- Place the hoop on a flat surface.
- Trim the excess vinyl as close to the cut line stitching as possible.

**Note:** If the outermost stitches (cut line) are cut, the inner stitches (tackdown) will hold the applique in place.

**Tip:** If the stabilizer is cut or a hole is created while trimming the fabric, use OESD Expert Embroidery Tape WashAway as a patch.



## STEP 11

- Return the hoop to the machine and stitch the remaining steps per the thread chart.
- Match the bobbin thread to the upper thread.



## STEP 12

- When the design is complete, remove the project from the hoop and trim the stabilizer 1/4" - 1/2" outside the design.



# ASSEMBLY

## STEP 13

- Rinse in warm running water until the design is only slightly tacky.
- Place right side down on a non-stick surface to dry. Parchment paper or a cooling rack will prevent curling. Dry completely.
- Once dry, press right side down on a Perfect Embroidery Press Cloth.



## STEP 14

- Use the OESD MiniMAT and Punch Tool with the 3mm attachment to create the eyelets indicated in the diagram.  
**Tip:** Take care to not cut the satin stitching.
- Reference the Punch Tool Guide on page 23.

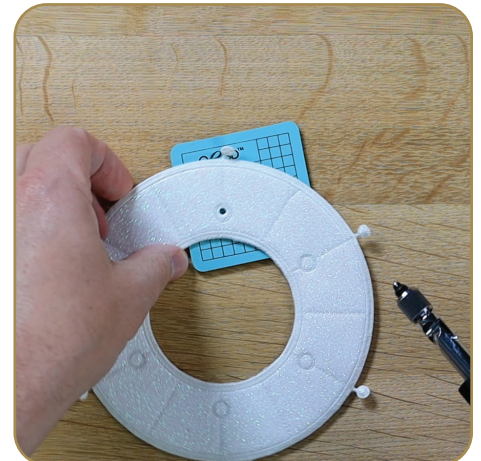

## STEP 15

- Line up the Trunk Sections FSA (12954-01) to connect.
- Thread the sewing machine with matching thread in the top and bobbin.
- Stitch together using a multi-step zigzag stitch.
- Back stitch at the beginning and end to secure.
- Trim thread tails.
- Set aside.

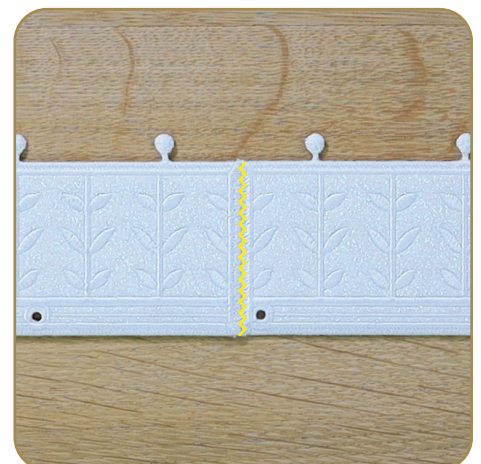

## STEP 16

- Line up the Layer 1 Section 1 FSA (12954-04) and Layer 1 Section 2 FSA (12954-05) to connect.
- Stitch together using a multi-step zigzag stitch.
- Back stitch at the beginning and end to secure.
- Trim thread tails.
- Set aside.

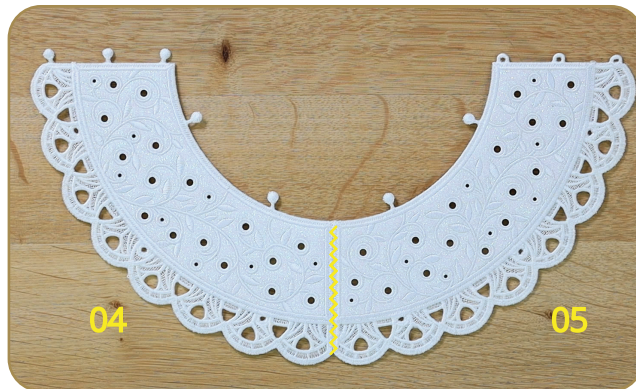

## STEP 17

- Line up the Layer 2 Section 1 FSA (12954-07) and Layer 2 Section 2 FSA (12954-08) to connect.
- Stitch together using a multi-step zigzag stitch.
- Back stitch at the beginning and end to secure.
- Trim thread tails.
- Set aside.

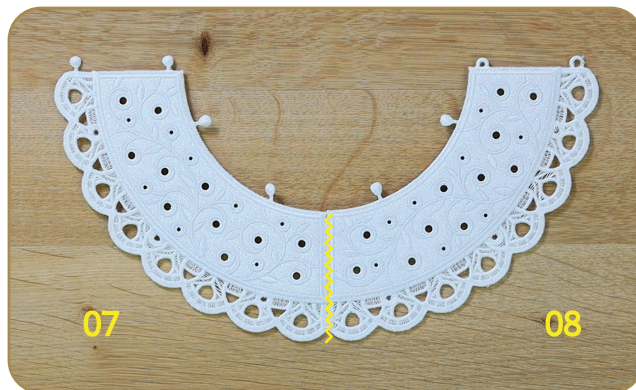

## STEP 18

- Match the buttonettes to the eyelets of the Trunk Sections FSA (12954-01).
- Use Alligator Clamps to pull each buttonette through the corresponding eyelet, using button clips to temporarily hold them in place, as needed.

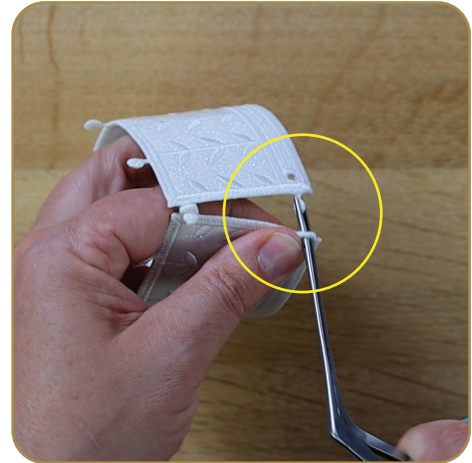
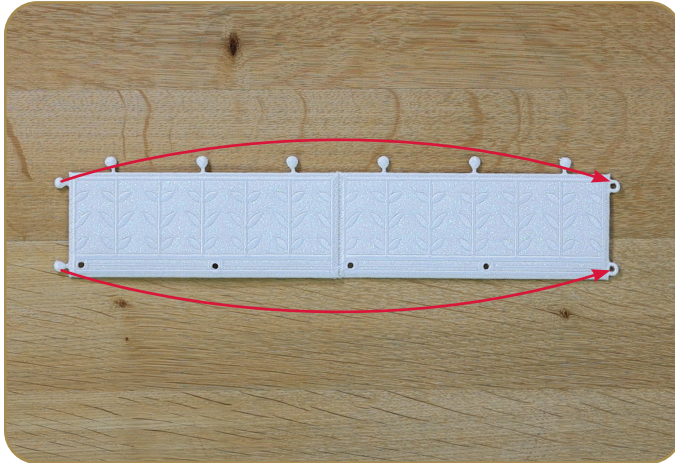

## STEP 19

- Align the stitched registration point with the buttonette seam.
- Match the buttonettes of the Trunk Base FSA (12954-02) to the eyelets of the Trunk Sections FSA (12954-01).
- Pull each buttonette through the corresponding eyelet.

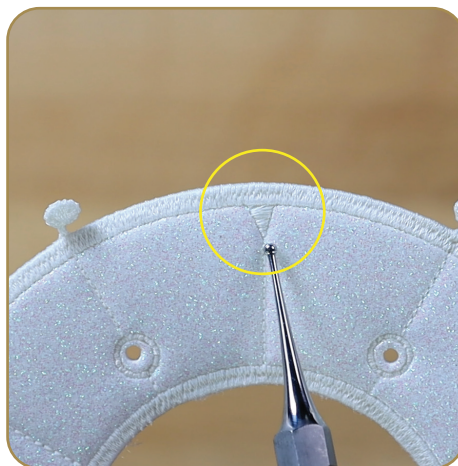

# ASSEMBLY

## STEP 20

- Align the stitched registration point with the buttonette seam.
- Match the buttonettes of the assembled Trunk Base FSA to the eyelets of the Layer 1 Base FSA (12954-03).
- Pull each buttonette through the corresponding eyelet.

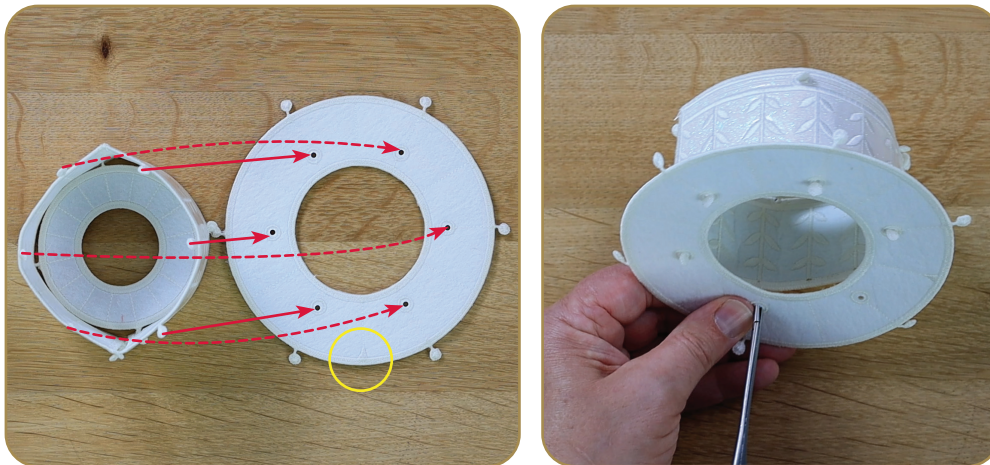

## STEP 21

- Match the buttonettes of Layer 1 Section 1 FSA (12954-04) to the eyelets of Layer 1 Section 2 FSA (12954-05).
- Pull each buttonette through the corresponding eyelet.

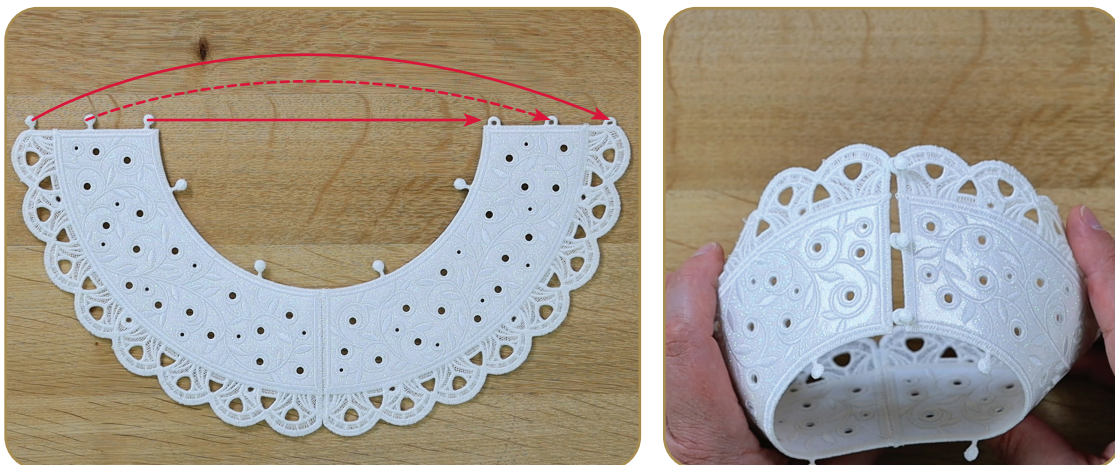

# ASSEMBLY

## STEP 22

- Align the stitched registration point with the buttonette seam.
- Match the buttonettes of the Layer 1 Base FSA (12954-03) to the eyelets of assembled Layer 1 Sections.
- Pull each buttonette through the corresponding eyelet.

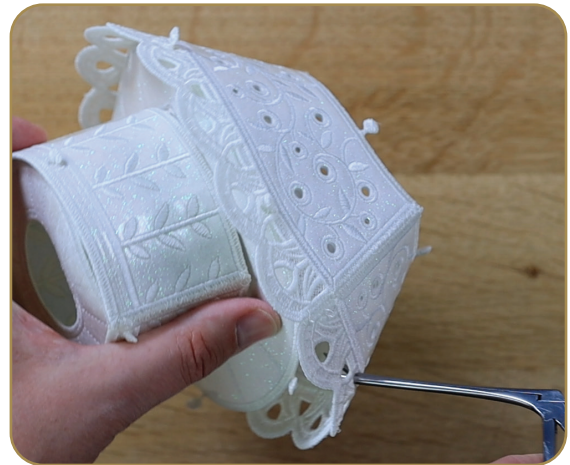
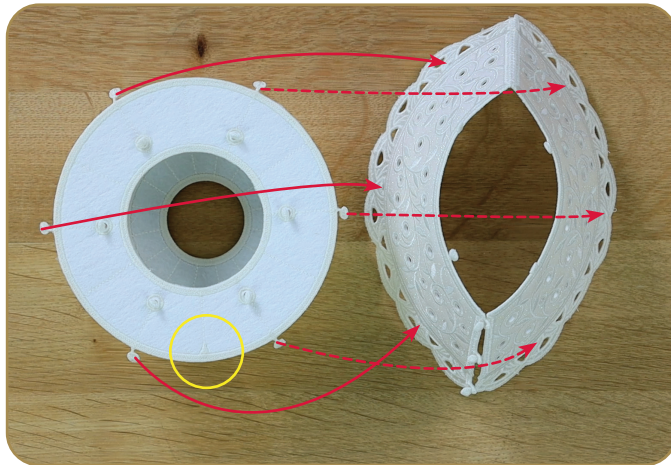

## STEP 23

- Align the stitched registration point with the buttonette seam.
- Match the buttonettes of the assembled Layer 1 Sections to the eyelets of the Layer 2 Base FSA (12954-06).
- Pull each buttonette through the corresponding eyelet.

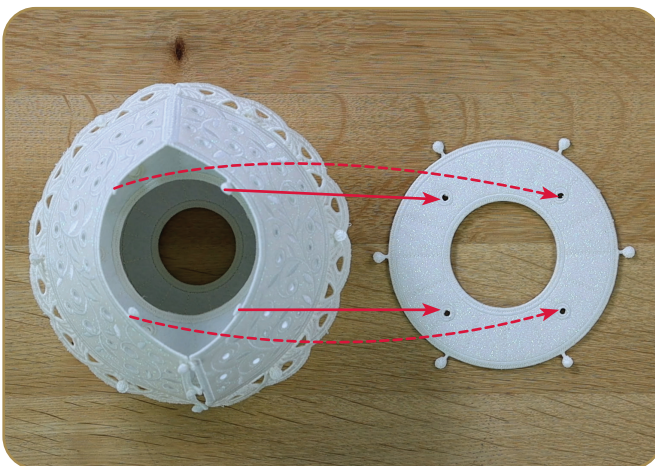

# ASSEMBLY

## STEP 24

- Match the buttonettes of Layer 2 Section 1 FSA (12954-07) to the eyelets of Layer 2 Section 2 FSA (12954-08).
- Pull each buttonette through the corresponding eyelet.

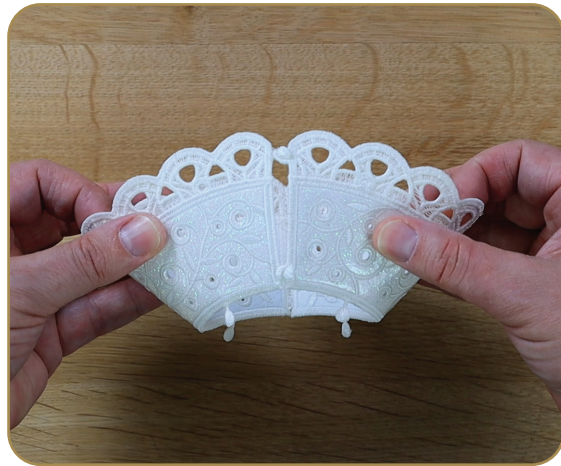
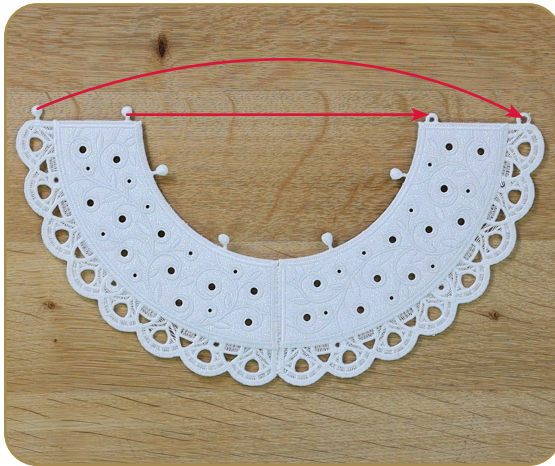

## STEP 25

- Align the stitched registration point with the buttonette seam.
- Match the buttonettes of the Layer 2 Base FSA (12954-06) to the eyelets of assembled Layer 2 Sections.
- Pull each buttonette through the corresponding eyelet.

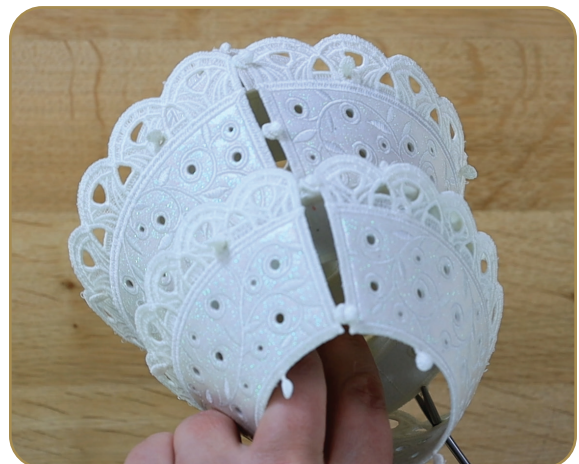
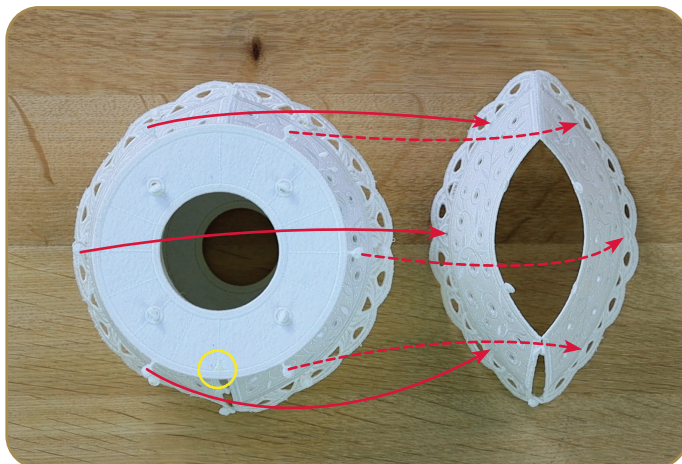



# ASSEMBLY

## STEP 26

- Align the stitched registration point with the buttonette seam.
- Match the buttonettes of the assembled Layer 2 Sections to the eyelets of the Layer 3 Base FSA (12954-09).
- Pull each buttonette through the corresponding eyelet.

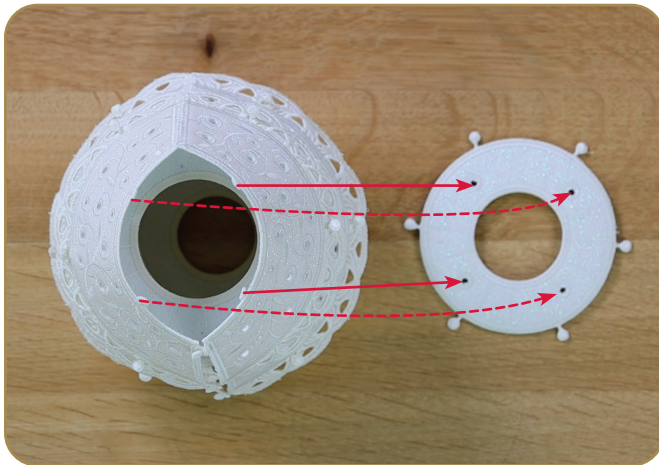

## STEP 27

- Match the buttonettes to the eyelets of Layer 3 Section FSA (12954-10).
- Pull each buttonette through the corresponding eyelet.

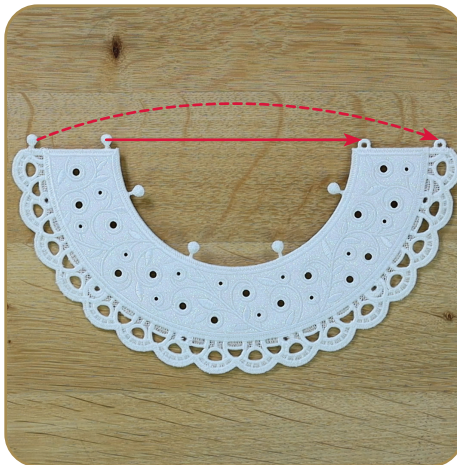

## STEP 28

- Align the stitched registration point with the buttonette seam.
- Match the buttonettes of the Layer 3 Base FSA (12954-09) to the eyelets of assembled Layer 3.
- Pull each buttonette through the corresponding eyelet.

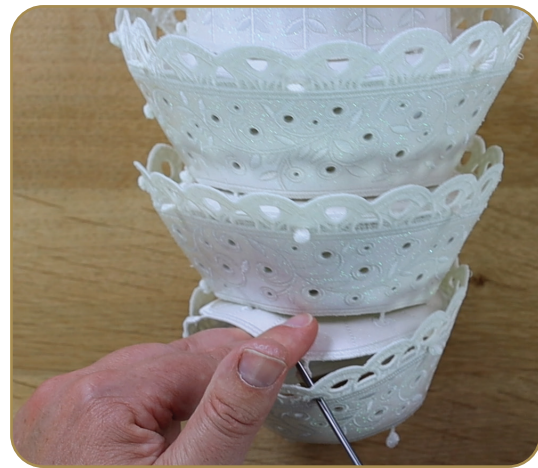
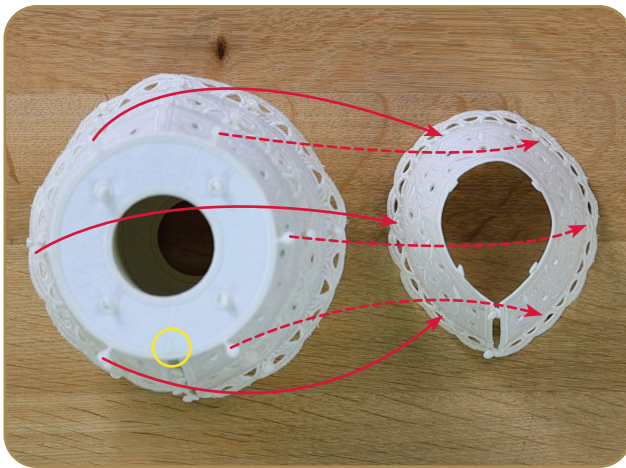

## STEP 29

- Align the stitched registration point with the buttonette seam.
- Match the buttonettes of the assembled Layer 3 to the eyelets of the Top Layer Base FSA (12954-11).
- Pull each buttonette through the corresponding eyelet.

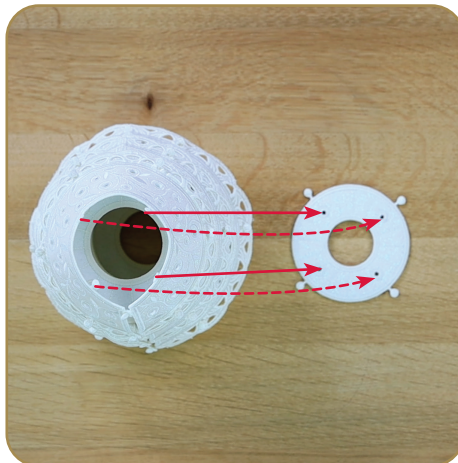

## STEP 30

- Match the buttonettes to the eyelets of the Top Layer FSA (12954-12).
- Pull each buttonette through the corresponding eyelet.

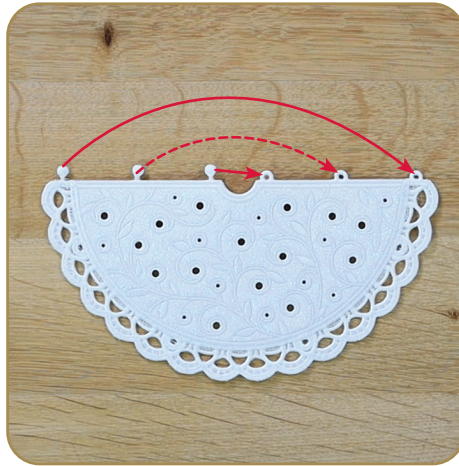

## STEP 31

- Align the stitched registration point with the buttonette seam.
- Match the buttonettes of the Top Layer Base FSA (12954-11) to the eyelets of assembled Top Layer.
- Pull each buttonette through the corresponding eyelet.

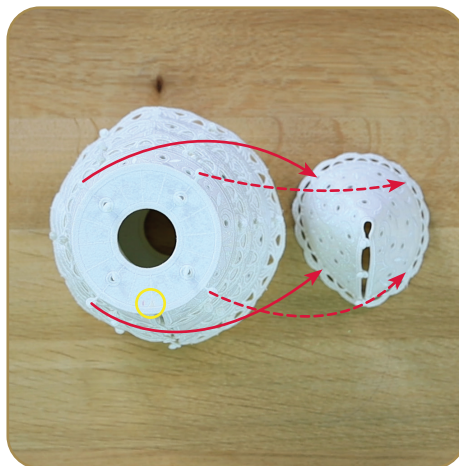

## STEP 32

- Roll the base of the Star Topper FSL (12954-13) small enough to insert in the opening of the assembled Top Layer.

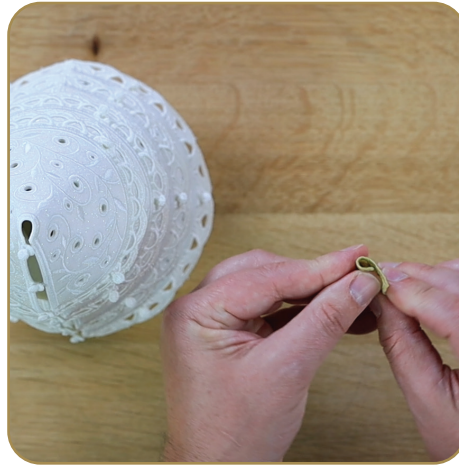

## STEP 33

- Insert the rolled base of the Star Topper FSL (12954-13) into the opening of the assembled Top Layer.



## STEP 34

- Add pixie lights and/or tiny ornaments.
- The project is complete. Enjoy!



## Stabilizer

- OESD AquaMesh
- OESD BadgeMaster

## Notions/Tools

- 80/12 Embroidery Ballpoint Titanium needle for extended needle life
- OESD Alligator Clamps
- OESD Button Clips
- OESD Perfect Point and Press Tool

## Isacord Thread Colors

- All OESD designs are digitized with Isacord 40 wt. polyester thread as the top thread and in the bobbin.
- Refer to the thread chart for color specifications.
- Match bobbin thread color to the top thread.

## Instructions

### Step 1 - Hoop

For FSL structures, hoop one layer of OESD AquaMesh and one layer of OESD BadgeMaster. BadgeMaster contains more starch so, combined with the AquaMesh, the lace is more rigid. For other FSL, where a softer lace is desired, hoop two layers of AquaMesh.

### Step 2 - Embroider

Stitch the design per the thread chart with matching thread in the bobbin at each color change. When complete, remove from the hoop and trim away excess stabilizer about 1/4"-1/2" from the stitching.

### Step 3 - Rinse

Rinse remaining stabilizer out in warm running water. For stiffer lace and FSL structures, DO NOT rinse away all of the stabilizer. The lace should be just slightly tacky. For softer lace, rinse until all traces of the stabilizer are removed.

### Step 4 - Dry

Lay right side down flat on a non-stick surface, such as a cooling rack, parchment paper or Teflon sheet. This minimizes the tendency for the lace to curl. Let the pieces dry completely before proceeding with any assembly.

### Step 5 - Press

Once completely dry, press right side down on a OESD Perfect Embroidery Press Cloth.

### Step 6 - Assemble Structure

Note: Specific assembly instructions for a design/collection may be found in the thread chart pdf following the individual design color charts.

Lace must be COMPLETELY DRY before assembly. Wetting the buttonettes or eyelets to assemble is not recommended and may result in them stretching and coming "unbuttoned" when dry.

Use a pair of OESD Alligator Clamps to insert the buttonettes into the eyelets. Insert the tip of the OESD Alligator Clamps into the eyelet, grasp the buttonette and pull through the eyelet. Alternatively, use a stiletto or tweezers to push the buttonette through the eyelet.

## Helpful Tips

### Limp Lace

If the design is not stiff enough, press the lace pieces on the wrong side while applying spray starch. After ironing, spray again with starch and allow to dry completely. This will stiffen the lace pieces nicely and aid in construction. Or easily re-stiffen by diluting some stabilizer scraps in water (or use liquid starch) and dipping the item in the solution. Lay flat to dry.

### Eyelets Too Small

If any of the eyelets appear closed or too small to penetrate with Alligator Clamps, they may be stretched by inserting the small end of the OESD Perfect Point and Press Tool into the eyelet opening and stretching it open wide enough to accommodate the OESD Alligator Clamps.

### Button Clips

During the assembly process, some structures pull on buttonettes that have already been inserted and could pull them out altogether. Putting a Button Clip on the assembled buttonette will keep it in position during the assembly process. Remove the Button Clips when the assembly is complete.

### Alternative Construction Option

In some cases, the buttonettes may be pulled to the inside of a project, instead of being visible on the outside. Insert the OESD Alligator Clamps through the eyelet from the wrong, or inside, of the lace and grasp the corresponding buttonette. Pull the buttonette to the wrong side of the lace.

Pulling the buttonettes to the inside may cause stress on the ones already done. Button clips may be placed on the completed buttonette(s) to prevent them from pulling out of the eyelet during construction.

# PUNCH TOOL GUIDES

12954-01

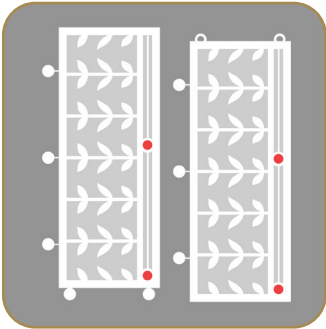

12954-03

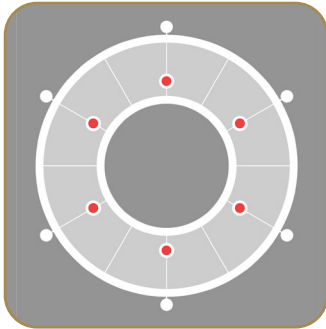

12954-04

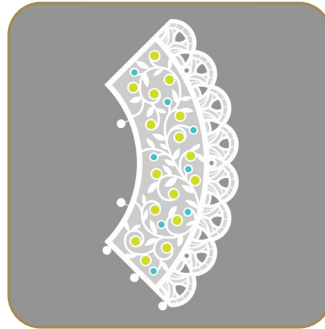

12954-05

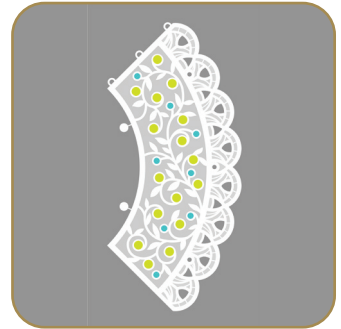

12954-06

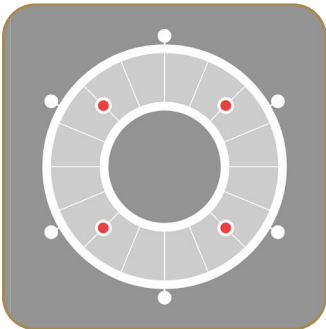

12954-07



12954-08

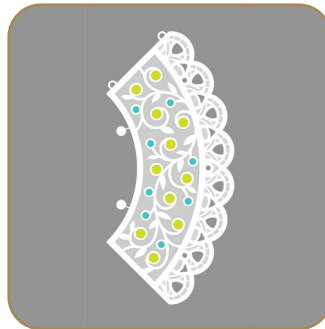

12954-09

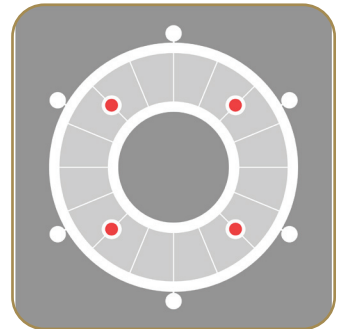

12954-10



12954-11

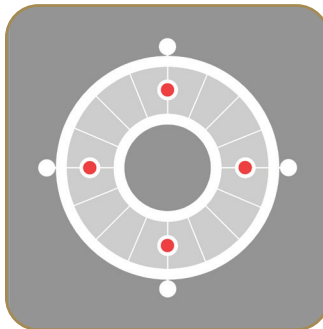

12954-12

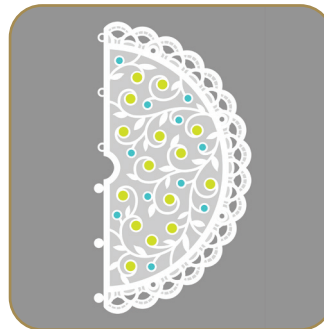

- = 2 MM
- = 3 MM
- = 4 MM

CRAFT KNIFE



## ATTENTION

When printing this document, any page scaling or page fitting options in your print dialog box must be turned OFF or set to NONE so that your files will print out at their actual size. Images not printed at actual size will not function as intended.

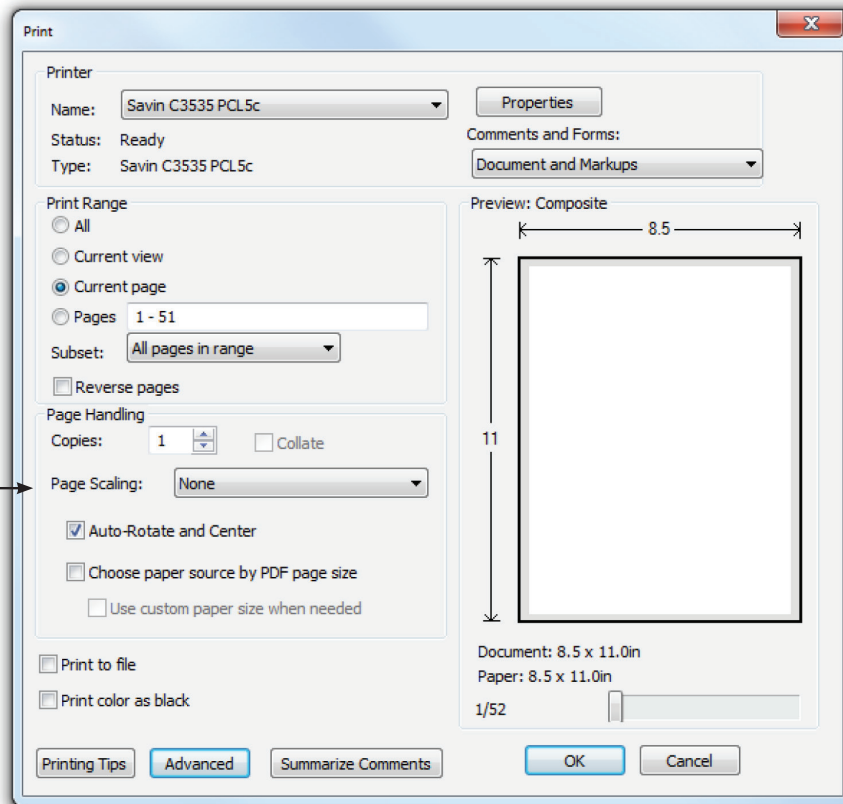

## TO SAVE PAPER

Only print the desired image by navigating to the image's page, go to File > Print and select "Current page" in the print dialog box. Repeat for each desired image.

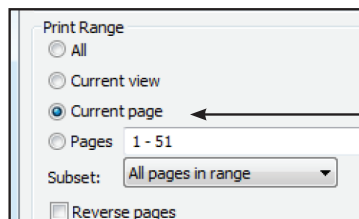



# APPLIQUE PATTERNS

Print at 100%. No scaling. This box measures 1" x 1". Use the box as an accuracy guide when printing templates.

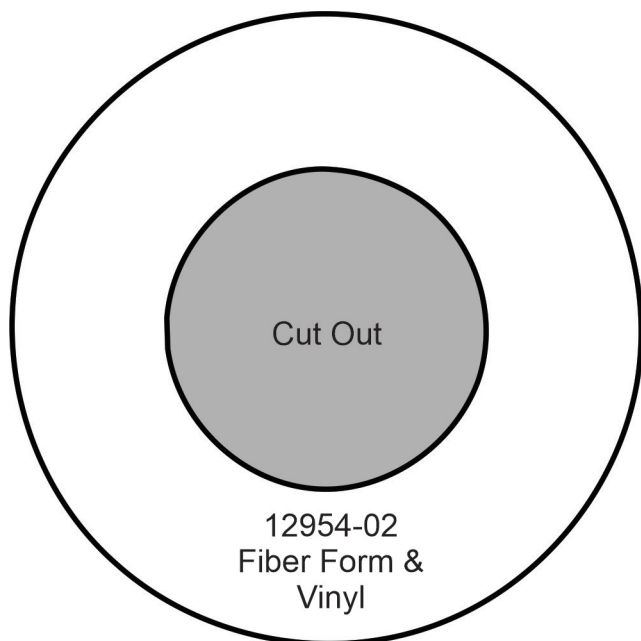
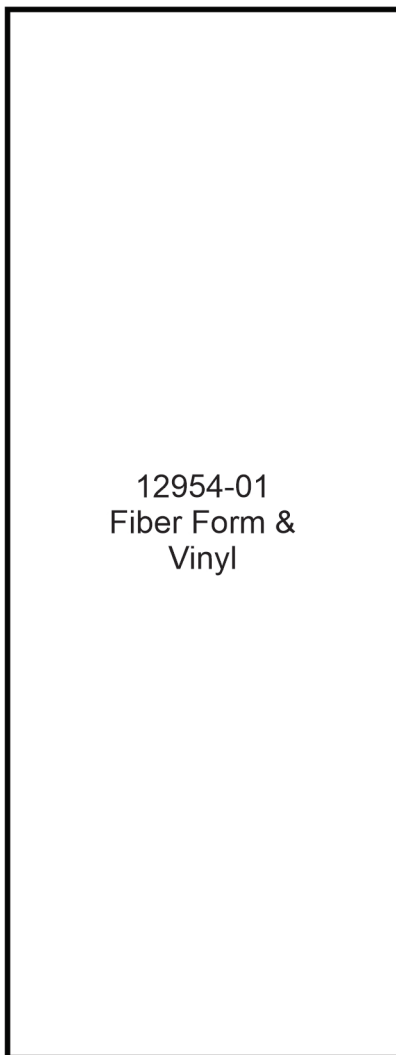

# APPLIQUE PATTERNS

Print at 100%. No scaling. This box measures 1" x 1". Use the box as an accuracy guide when printing templates.

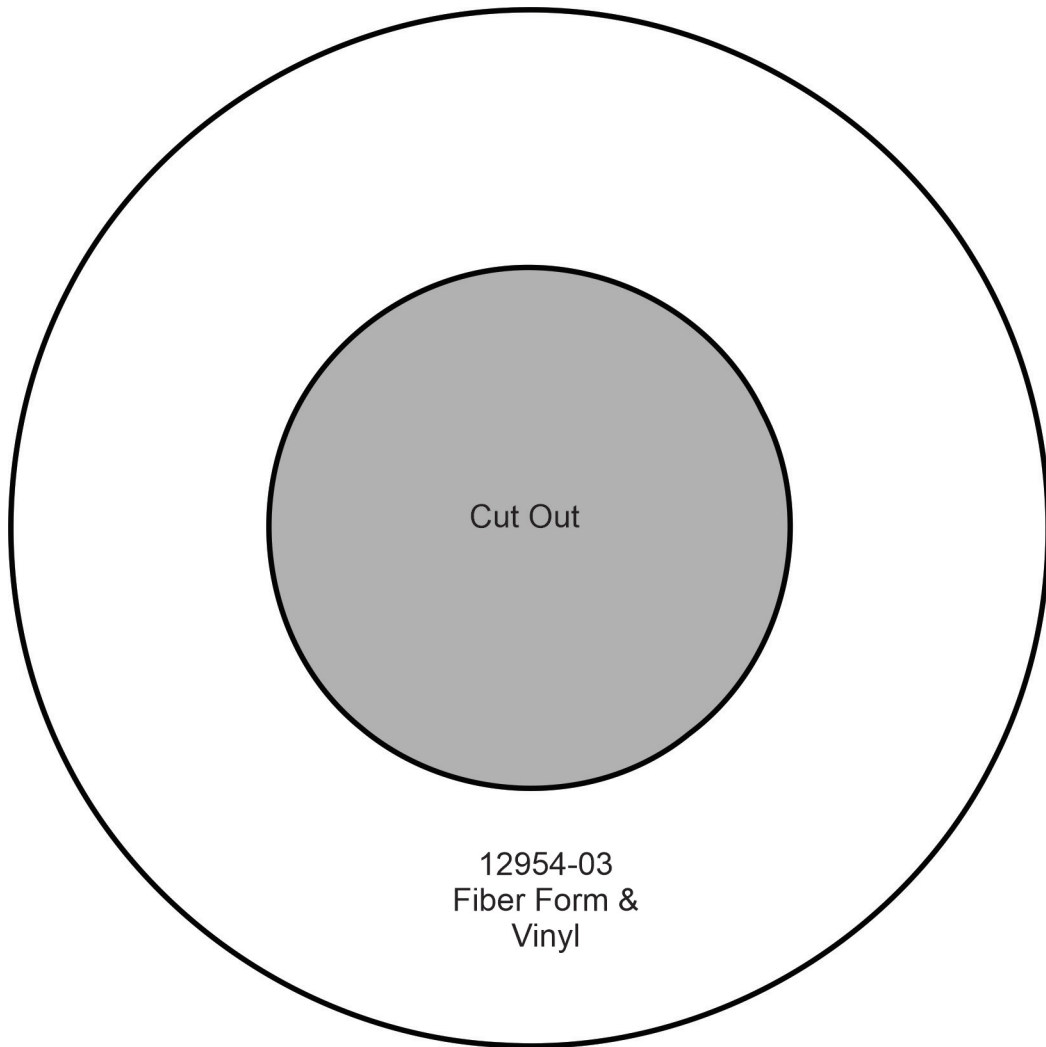

12954-03  
Fiber Form &  
Vinyl

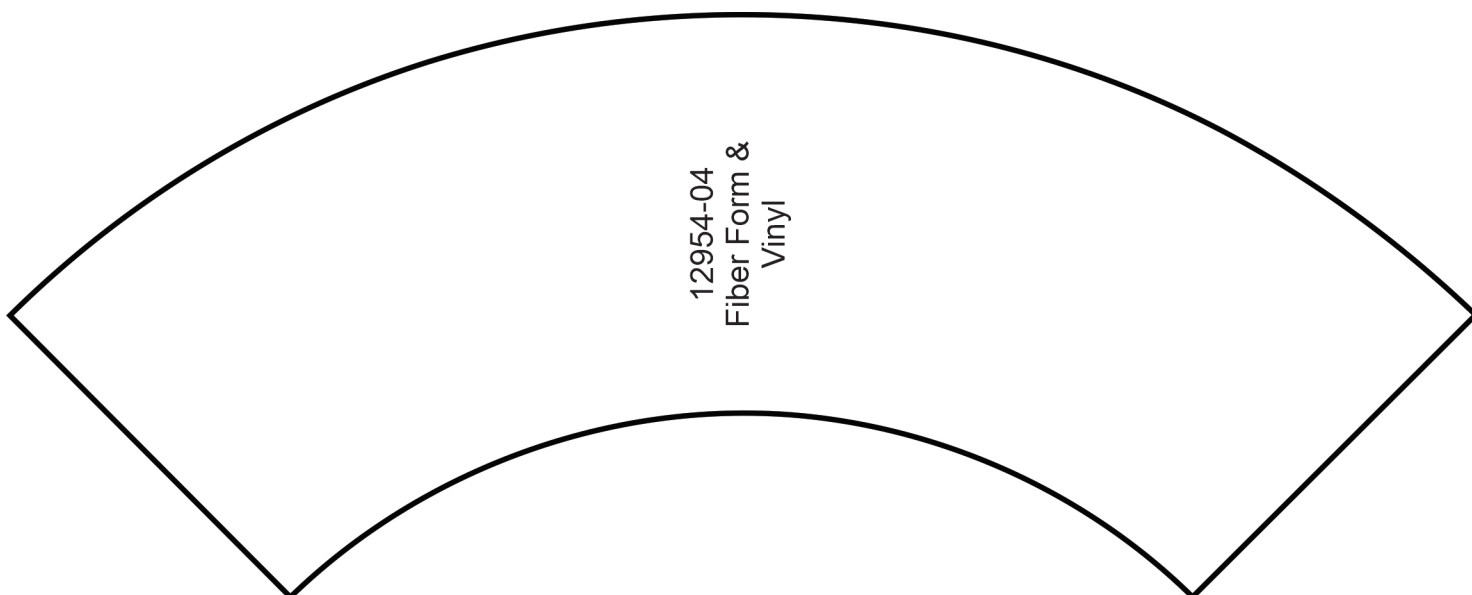

12954-04  
Fiber Form &  
Vinyl

# APPLIQUE PATTERNS

Print at 100%. No scaling. This box measures 1" x 1". Use the box as an accuracy guide when printing templates.

12954-05  
Fiber Form &  
Vinyl



Cut Out

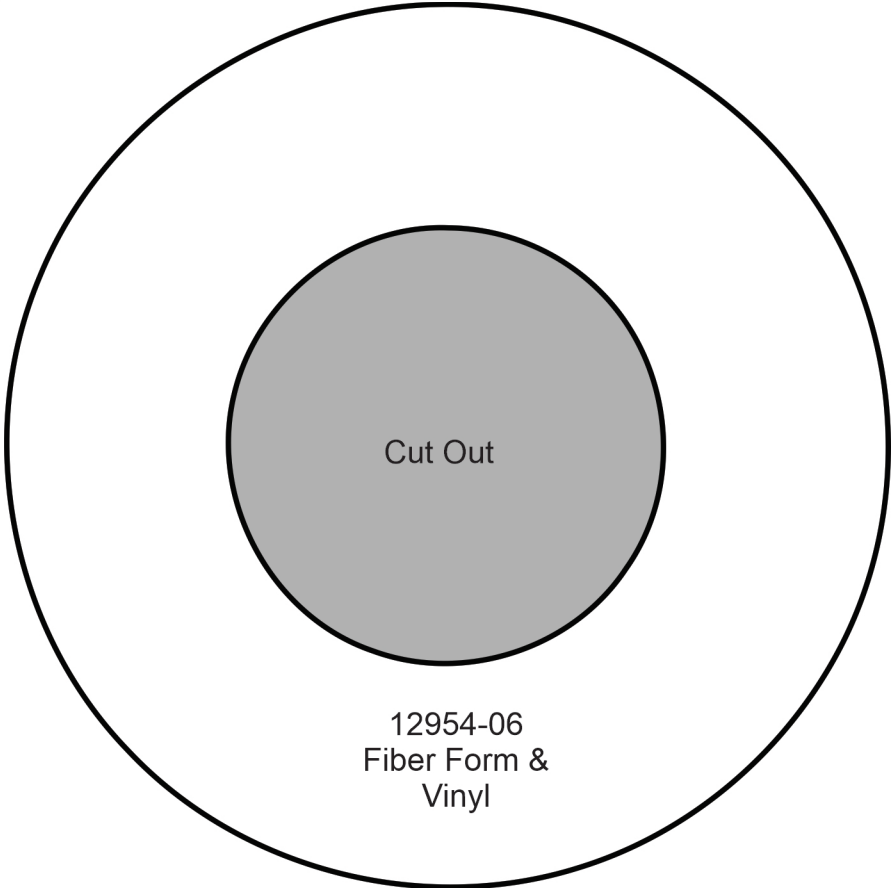

12954-06  
Fiber Form &  
Vinyl

# APPLIQUE PATTERNS

Print at 100%. No scaling. This box measures 1" x 1". Use the box as an accuracy guide when printing templates.

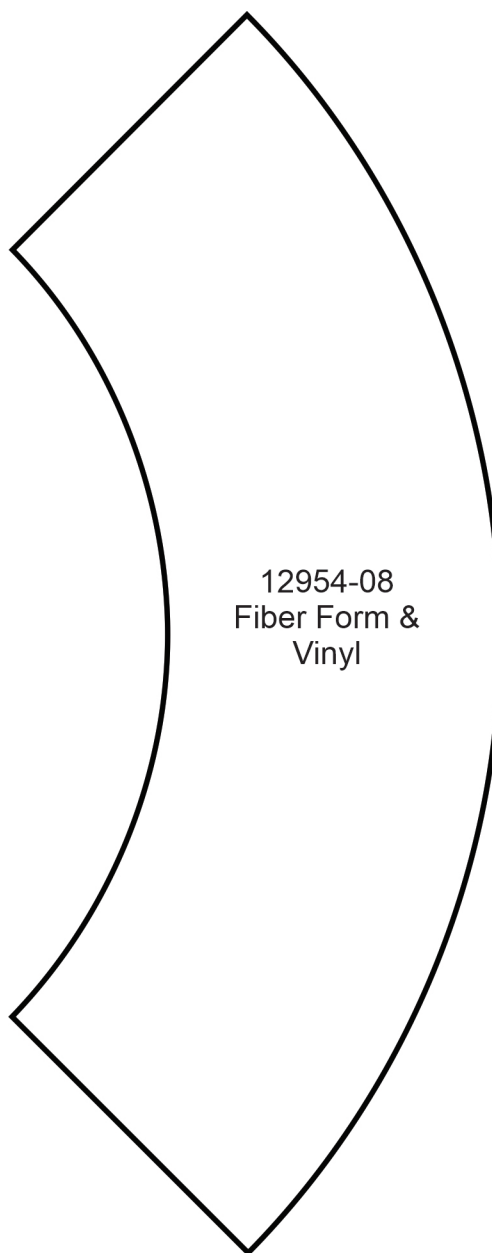
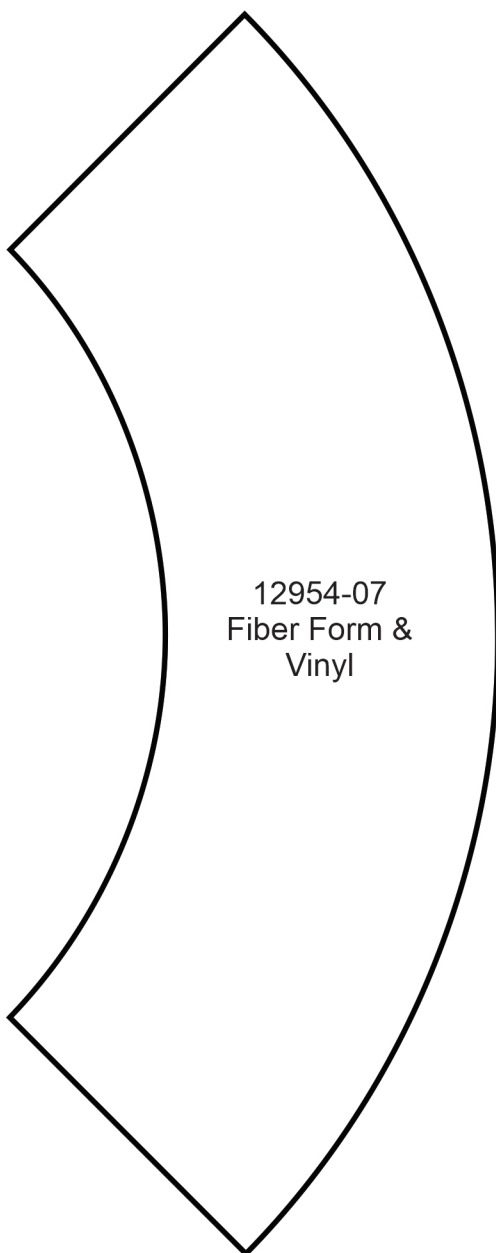

Print at 100%. No scaling. This box measures 1" x 1". Use the box as an accuracy guide when printing templates.

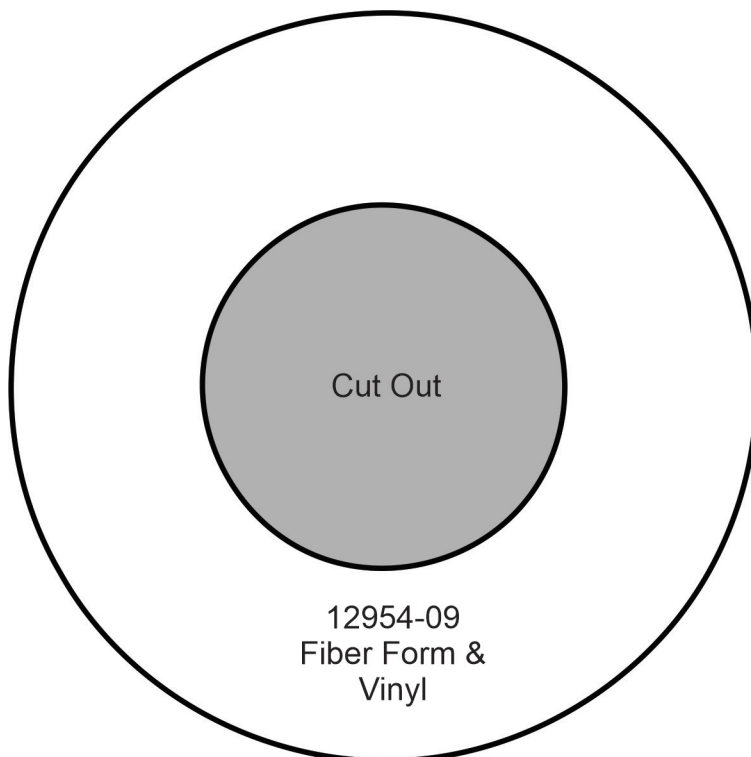
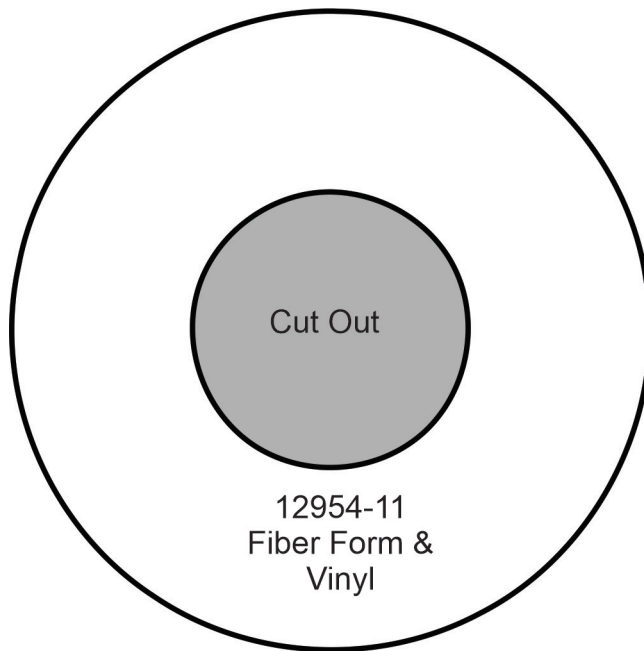

# APPLIQUE PATTERNS

Print at 100%. No scaling. This box measures 1" x 1". Use the box as an accuracy guide when printing templates.

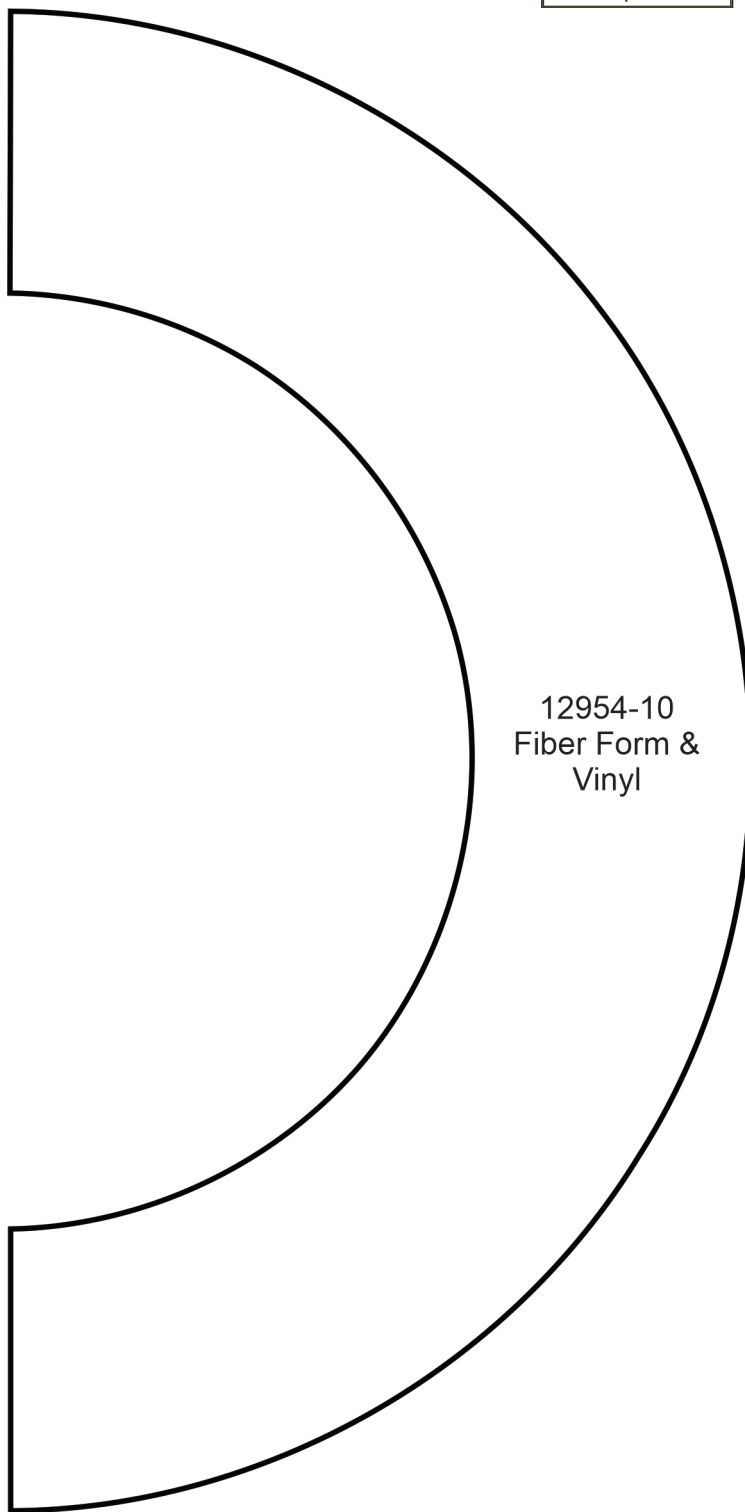
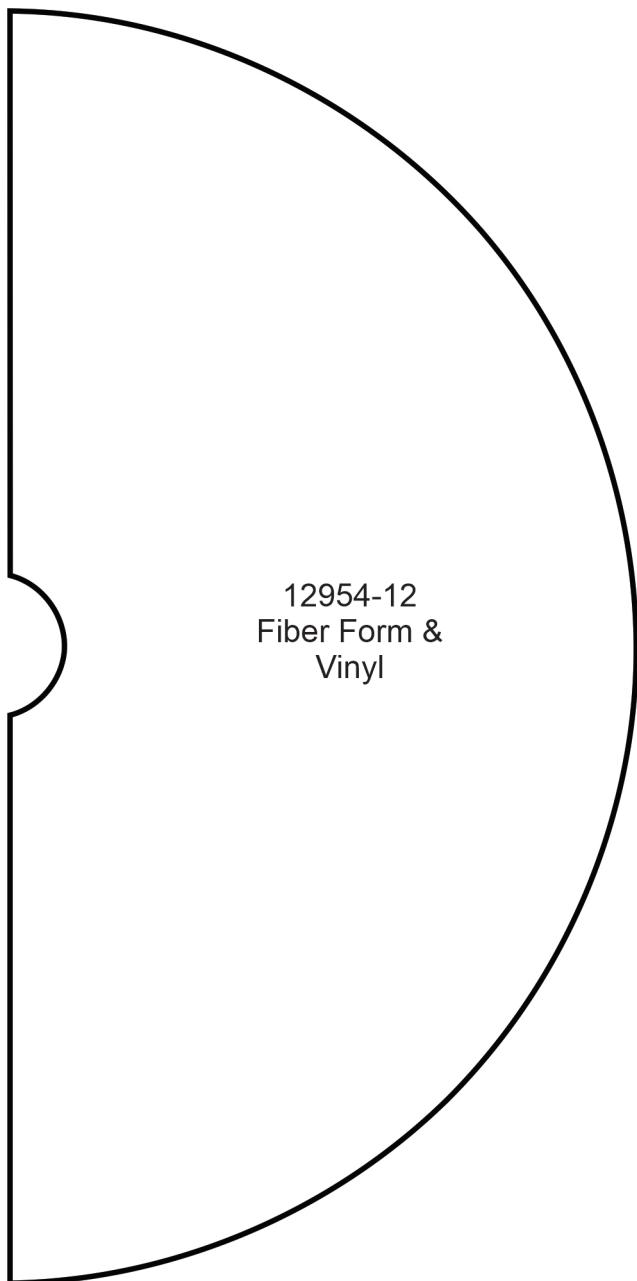

# MIRRORED PATTERNS

Print at 100%. No scaling. This box measures 1" x 1". Use the box as an accuracy guide when printing templates.

12954-01  
Fiber Form &  
Vinyl  
Mirrored

12954-01  
Fiber Form &  
Vinyl  
Mirrored

Cut Out

12954-02  
Fiber Form &  
Vinyl  
Mirrored

# MIRRORED PATTERNS

Print at 100%. No scaling. This box measures 1" x 1". Use the box as an accuracy guide when printing templates.

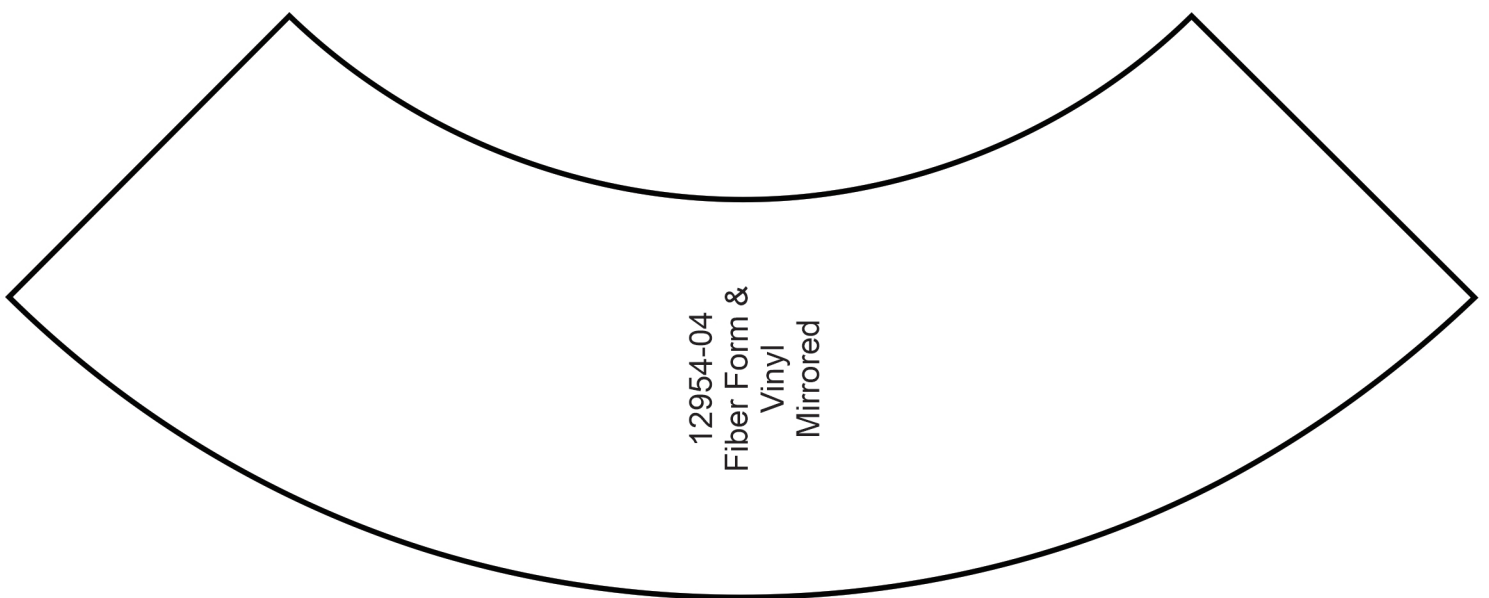
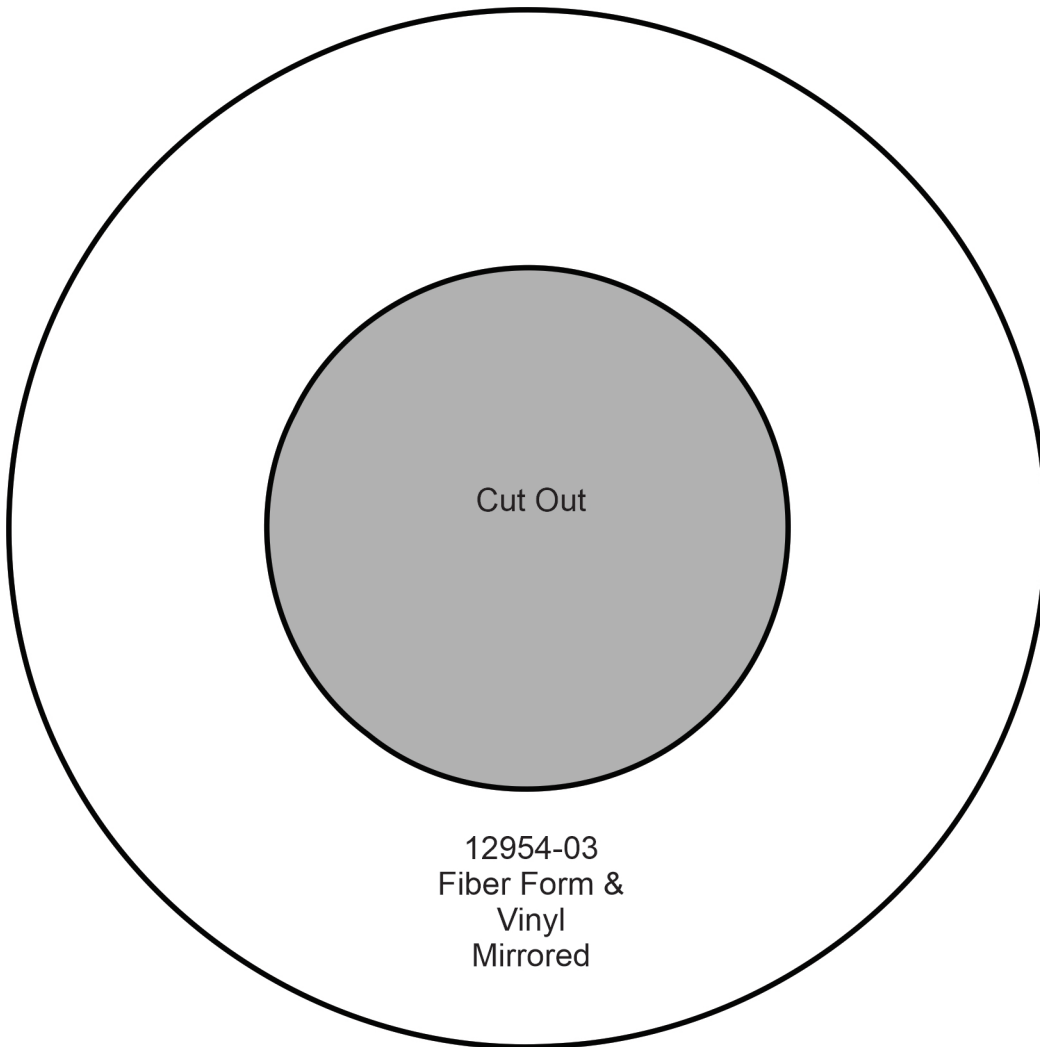



# MIRRORED PATTERNS

Print at 100%. No scaling. This box measures 1" x 1". Use the box as an accuracy guide when printing templates.

12954-05  
Fiber Form &  
Vinyl  
Mirrored

Cut Out

12954-06  
Fiber Form &  
Vinyl  
Mirrored

# MIRRORED PATTERNS

Print at 100%. No scaling. This box measures 1" x 1". Use the box as an accuracy guide when printing templates.

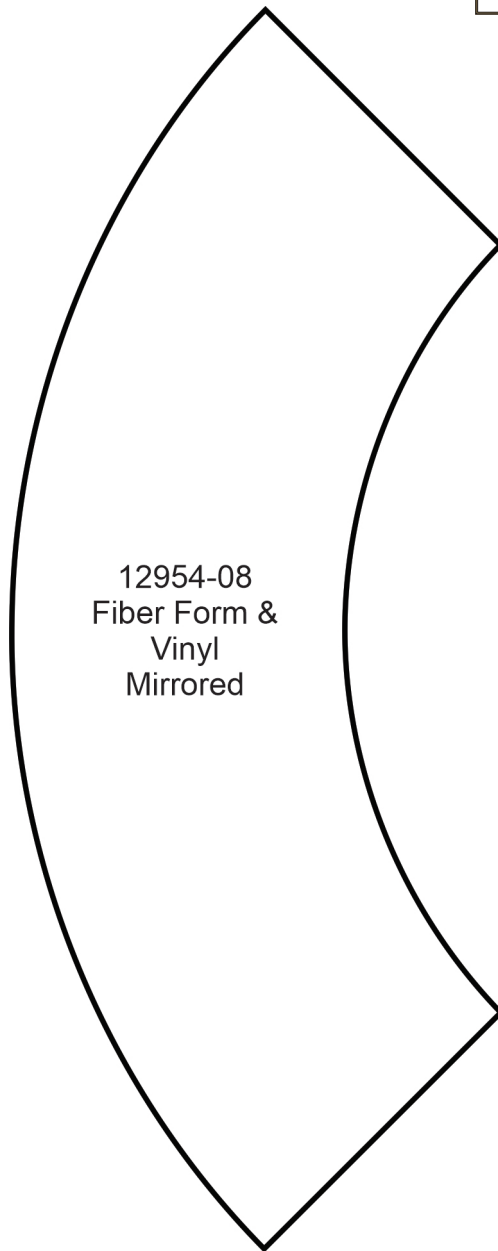
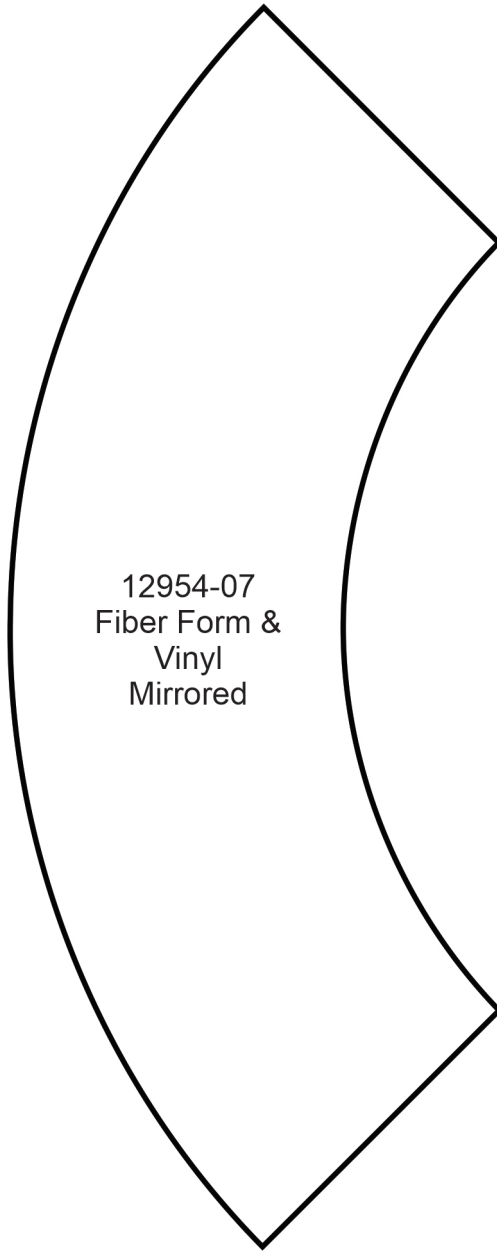

Print at 100%. No scaling. This box measures 1" x 1". Use the box as an accuracy guide when printing templates.

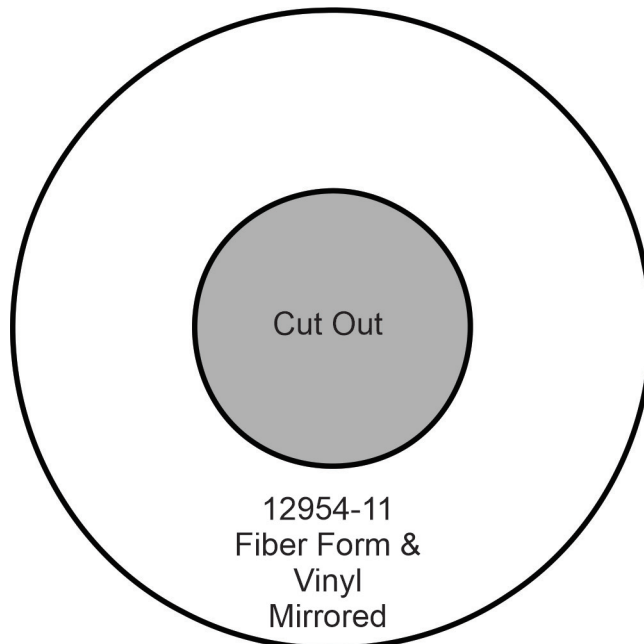
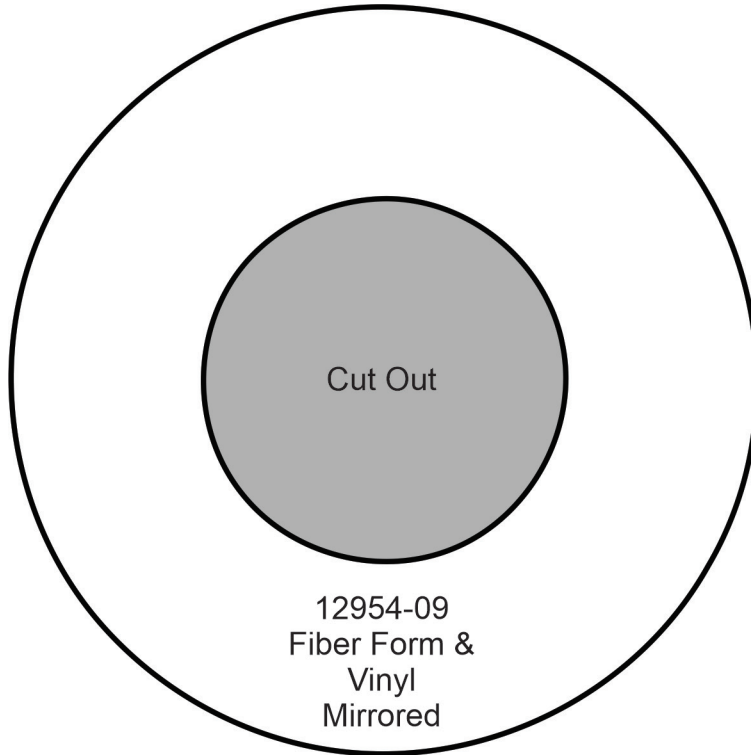

# MIRRORED PATTERNS

Print at 100%. No scaling. This box measures 1" x 1". Use the box as an accuracy guide when printing templates.



12954-10  
Fiber Form &  
Vinyl  
Mirrored

The image shows a large, mirrored, semi-circular pattern. It consists of two concentric semi-circular arcs. The outer arc is on the left, and the inner arc is on the right. The space between the two arcs is the intended shape for the fiber form and vinyl. The pattern is symmetrical about a vertical line through its center.



12954-12  
Fiber Form &  
Vinyl  
Mirrored

The image shows a large, mirrored, semi-circular pattern. It consists of two concentric semi-circular arcs. The outer arc is on the left, and the inner arc is on the right. The space between the two arcs is the intended shape for the fiber form and vinyl. The pattern is symmetrical about a vertical line through its center. There is a small, semi-circular notch on the right side of the inner arc.