

Christmas Cheer Ornaments

Christmas
cheer



Collection No. 12968
15 Design/25 Files

MATERIALS



Isacord Thread Colors

- 0003 Ghost White
- 1720 Not Quite Red
- 1840 Corsage
- 1911 Foliage Rose
- 2250 Petal Pink
- 4752 Vintage Blue
- 5324 Bright Green
- 6011 Tamarack

Note: One spool of 1000 meter thread is adequate for the project unless otherwise noted.



MATERIALS



Stabilizers

- OESD AquaMesh WashAway
- OESD BadgeMaster WashAway
- OESD StabilStick CutAway
- OESD Fiber Form
- OESD Applique Fuse and Fix

Fabrics/Textiles

- Quilter's cotton various colors

Notion & Tools

- OESD Grippy GRID
- OESD Perfect Scoring Tool
- OESD Expert Embroidery Tape TearAway
- OESD Expert Embroidery Tape WashAway
- OESD Perfect Punch Tool
- OESD Mini MAT
- OESD Alligator Clamps
- OESD Button Clips
- OESD Perfect Embroidery Press Cloth
- Embroidery Needle Sharp 75/11 (FSA)
- Embroidery Needle Ballpoint 80/12 (FSL)
- 1/8" ribbon, various colors

Isacord Thread Colors

- Per the thread chart
- Match bobbin thread to top thread



SUMMARY

12968-01
Ornament 1 Section 1
FSA

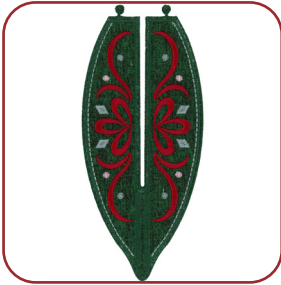

Requires 1 Design



12968-02
Ornament 1 Section 2
FSA

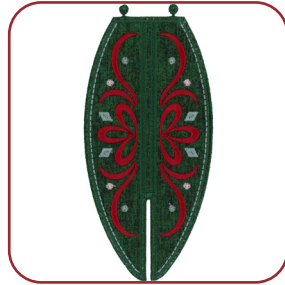

Requires 1 Design



12968-03
Ornament 1 Cap FSL

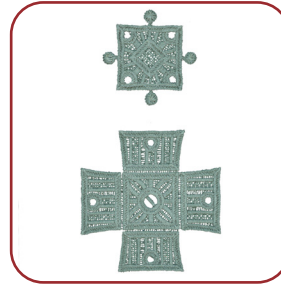

Requires 1 Design



12968-24
Ornament Charm 4
FSL

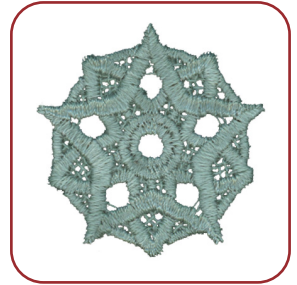

Requires 1 Design



SUMMARY

12968-04
Ornament 2 Section 1
FSA



Requires 1 Design



12968-05
Ornament 2 Section 2
FSA



Requires 1 Design



12968-06
Ornament 1 Cap FSL



Requires 1 Design



12968-21
Ornament Charm 1
FSL



Requires 1 Design



SUMMARY

12968-07
Ornament 3 Section 1
FSA

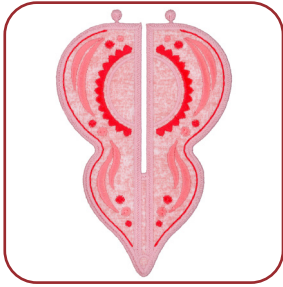

Requires 1 Design



12968-08
Ornament 3 Section 2
FSA

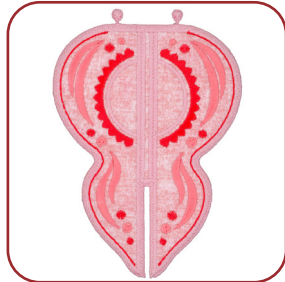

Requires 1 Design



12968-09
Ornament 3 Cap
FSL

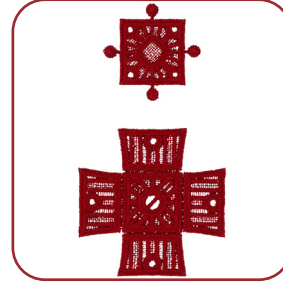

Requires 1 Design



12968-22
Ornament Charm 2
FSL



Requires 1 Design



SUMMARY

12968-10
Ornament 4 Section 1
FSA



Requires 1 Design



12968-11
Ornament 4 Section 2
FSA



Requires 1 Design



12968-12
Ornament 4 Cap FSL

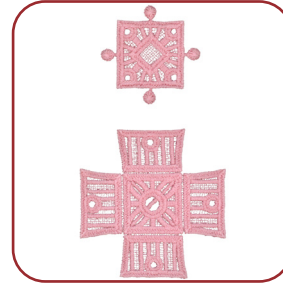

Requires 1 Design



12968-23
Ornament Charm 3
FSL



Requires 1 Design



SUMMARY

12968-13
Ornament 5 Section 1
FSA

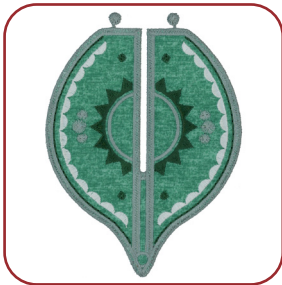

Requires 1 Design



12968-14
Ornament 5 Section 2
FSA

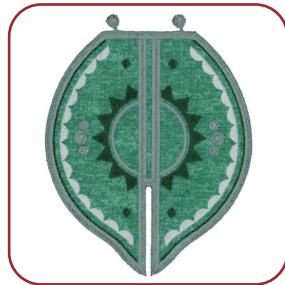

Requires 1 Design



12968-15
Ornament 5 Cap FSL

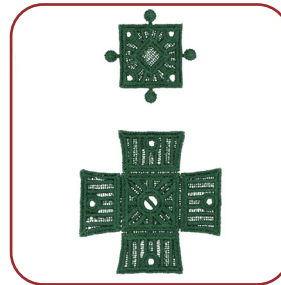

Requires 1 Design



12968-25
Ornament Charm 5
FSL



Requires 1 Design



SUMMARY

12968-16
Ornament 6 FSA



Requires 1 Design

12968-21
Ornament Charm 1 FSL

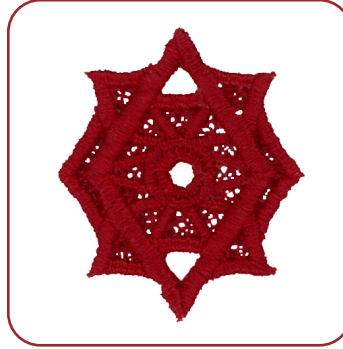

Requires 1 Design



12968-17
Ornament 7 FSA

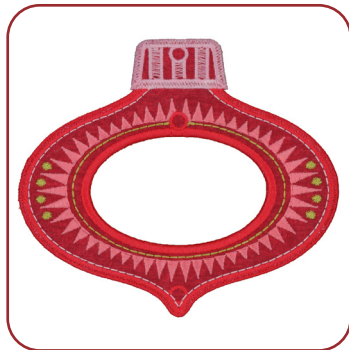

Requires 1 Design

12968-22
Ornament Charm 2 FSL



Requires 1 Design



12968-18
Ornament 8 FSA



Requires 1 Design

12968-23
Ornament Charm 3 FSL



Requires 1 Design



Requires 1 Design



SUMMARY

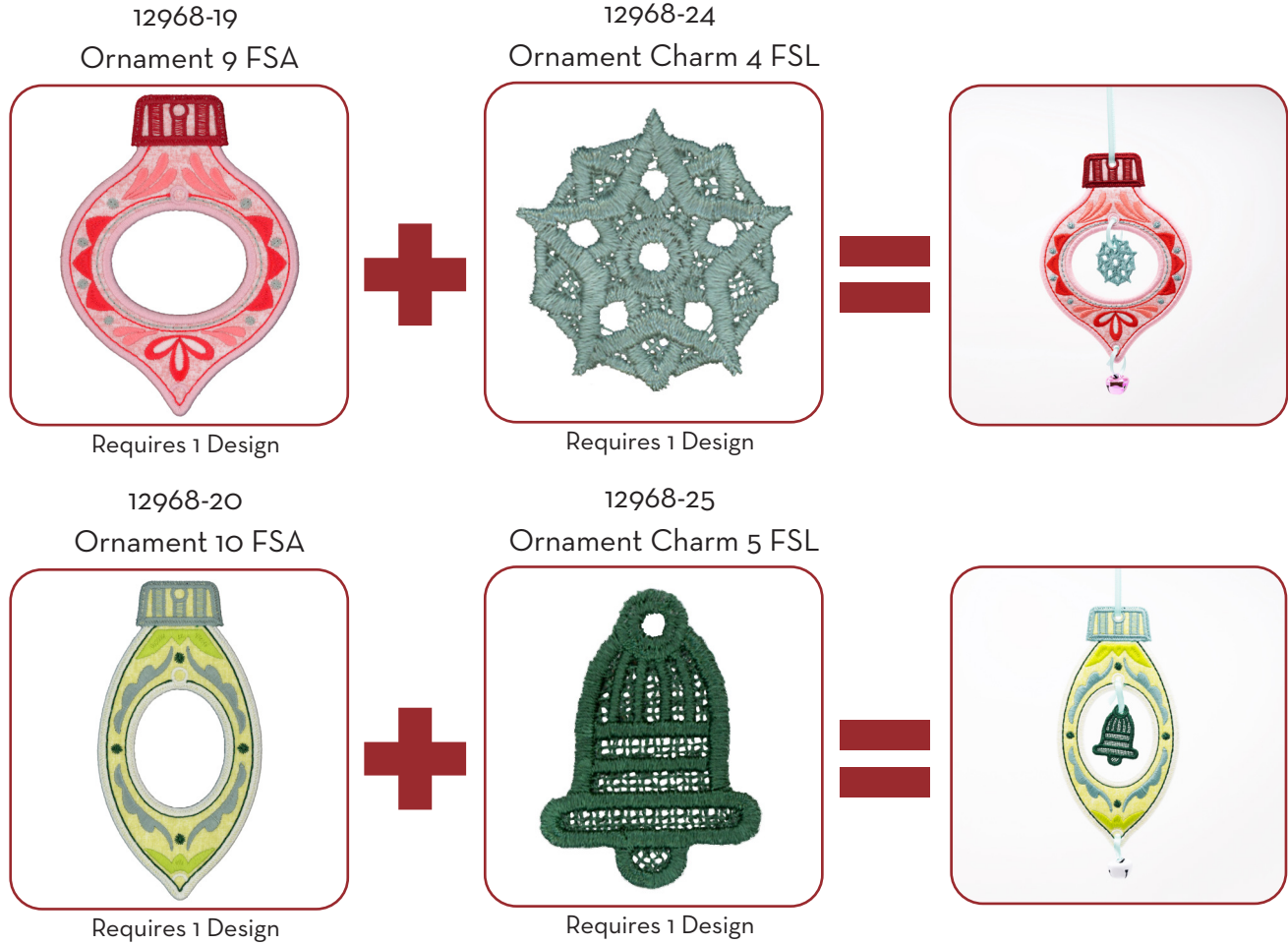

General Instructions

The freestanding applique instructions, included in the collection, are general instructions. For demonstration purposes, a sample design that best demonstrates the technique is shown. Fabric and thread requirements will vary by design, but the general technique is the same.

All designs are stitched with matching thread, top and bobbin.

Note: Some thread colors in the instructions have been changed or digitally enhanced for better visibility.

Designs - Double Sided Freestanding Applique

Design Name	Design Number	Requires
Ornament 1 Section 1 FSA	12968-01	1
Ornament 1 Section 2 FSA	12968-02	1
Ornament 2 Section 1 FSA	12968-04	1
Ornament 2 Section 2 FSA	12968-05	1
Ornament 3 Section 1 FSA	12968-07	1
Ornament 3 Section 2 FSA	12968-08	1
Ornament 4 Section 1 FSA	12968-10	1
Ornament 4 Section 2 FSA	12968-11	1
Ornament 5 Section 1 FSA	12968-13	1
Ornament 5 Section 2 FSA	12968-14	1
Ornament 6 FSA	12968-16	1
Ornament 7 FSA	12968-17	1
Ornament 8 FSA	12968-18	1
Ornament 9 FSA	12968-19	1
Ornament 10 FSA	12968-20	1



Step 1

- Print the mirrored version of the templates (at 100% scale or 1:1 ratio) onto the paper side of Applique Fuse and Fix.
- Cut approximately 1/4" - 1/2" outside the printed applique templates.



Step 2

- Cut the Fiber Form 1/4" - 1/2" larger than the applique templates.
- Fuse the trimmed templates to the back of the Fiber Form with the paper side of the printed template up. Hold the iron on the template for 10-15 seconds for a secure fuse.



Step 3

- Trim the Fiber Form on the edge of the black outline.
- Set aside.



Step 4

- Adhere one layer of StabilStick CutAway to the wrong side of all applique fabrics to provide stiffness to the finished ornament.
- Cut the prepared applique fabrics 1/4"-1/2" larger than the templates that are included at the end of the instructions.



Step 5

- Hoop one layer of AquaMesh and one layer of BadgeMaster for all designs.



Step 6

- Load selected design into the machine.
- Example design is 12968-07.
- Thread the machine per the thread chart.
- Place the hoop on the machine.
- Stitch Machine Step 1, Fiber Form/Front and Back Pink Fabric Placement Stitch.



Step 7

- Remove the hoop from the machine, but NOT the project from the hoop.
- Place the hoop on a flat surface.
- On the back of the Fiber Form, use the OESD Perfect Scoring Tool to score and remove the paper backing to reveal the adhesive surface.
- Place the Fiber Form within the placement stitching.
- Finger press to secure.



Step 8

- Completely cover the Fiber Form with the prepared applique fabric.
- Tape in place to secure.

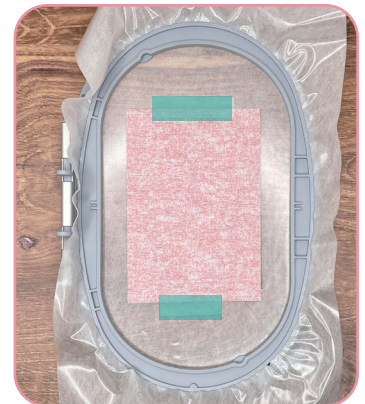

Step 9

- Turn the hoop over and place the prepared applique fabric, right side up, completely covering the placement stitch.
- Carefully tape to secure.
- Tip: Avoid pushing too hard on the stabilizer to prevent it from dislodging from the hoop.



□ Step 10

- Return the hoop to the machine.
- Stitch Machine Step 2, Cut Line and Tackdown.

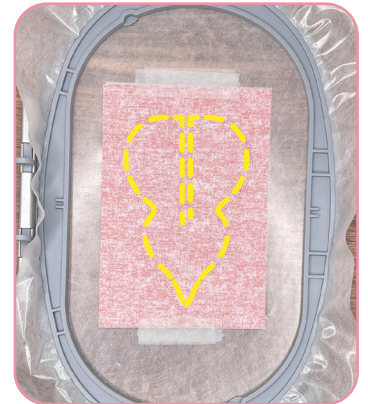

□ Step 11

- Remove the hoop from the machine, but NOT the project from the hoop.
- Trim the excess fabric as close to the cut line as possible. If the outermost stitches (cut line) are cut, the inner stitches (tackdown) will hold the applique in place.
- Tip: If the stabilizer is cut or a hole is created while trimming the fabric, use OESD Expert Embroidery Tape WashAway as a patch.



□ Step 12

- Turn the hoop over and trim the excess fabric as close to the cut line as possible.



GENERAL FREESTANDING LACE GUIDE



Stabilizer

- OESD AquaMesh
- OESD BadgeMaster

Notion/Tools

- 80/12 Embroidery Ballpoint Titanium needle for extended needle life
- OESD Alligator Clamps
- OESD Button Clips
- OESD Perfect Point and Press Tool

Isacord Thread Colors

- All OESD designs are digitized with Isacord 40 wt. polyester thread as the top thread and in the bobbin.
- Refer to the thread chart for color specifications.
- Match bobbin thread color to the top thread.

Instructions

Step 1 - Hoop

For FSL structures, hoop one layer of OESD AquaMesh and one layer of OESD BadgeMaster. BadgeMaster contains more starch so, combined with the AquaMesh, the lace is more rigid.

For other FSL, where a softer lace is desired, hoop two layers of AquaMesh.

Step 2 - Embroider

Stitch the design per the thread chart with matching thread in the bobbin at each color change.

When complete, remove from the hoop and trim away excess stabilizer about 1/4"-1/2" from the stitching.

Step 3 - Rinse

Rinse remaining stabilizer out in warm running water.

For stiffer lace and FSL structures, DO NOT rinse away all of the stabilizer. The lace should be just slightly tacky.

For softer lace, rinse until all traces of the stabilizer is removed.

Step 4 - Dry

Lay right side down flat on a non-stick surface, such as a cookie rack, parchment paper or Teflon sheet. This minimizes the tendency for the lace to curl.

Let the pieces dry completely before proceeding with any assembly.

Step 5 - Press

Once completely dry, press right side down on a OESD Perfect Embroidery Press Cloth.

Step 6 - Assemble Structure

Note: Specific assembly instructions for a design/collection may be found in the thread chart pdf following the individual design color charts.

Lace must be COMPLETELY DRY before assembly. Wetting the buttonettes or eyelets to assemble is not recommended and may result in them stretching and coming "unbuttoned" when dry.

Use a pair of OESD Alligator Clamps to insert the buttonettes into the eyelets. Insert the tip of the OESD Alligator Clamps into the eyelet, grasp the buttonette and pull through the eyelet. Alternatively, use a stiletto or tweezers to push the buttonette through the eyelet.

Helpful Tips

Limp Lace

If the design is not stiff enough, press the lace pieces on the wrong side while applying spray starch. After ironing, spray again with starch and allow to dry completely. This will stiffen the lace pieces nicely and aid in construction. Or easily re-stiffen by diluting some stabilizer scraps in water (or use liquid starch) and dipping the item in the solution. Lay flat to dry.

Eyelets Too Small

If any of the eyelets appear closed or too small to penetrate with Alligator Clamps, they may be stretched by inserting the small end of the OESD Perfect Point and Press Tool into the eyelet opening and stretching it open wide enough to accommodate the OESD Alligator Clamps.

Button Clips

During the assembly process, some structures pull on buttonettes that have already been inserted and could pull them out altogether. Putting a Button Clip on the assembled buttonette will keep it in position during the assembly process. Remove the Button Clips when the assembly is complete.

Alternative Construction Option

In some cases, the buttonettes may be pulled to the inside of a project, instead of being visible on the outside.

Insert the OESD Alligator Clamps through the eyelet from the wrong, or inside, of the lace and grasp the corresponding buttonette. Pull the buttonette to the wrong side of the lace.

Pulling the buttonettes to the inside may cause stress on the ones already done. Button clips may be placed on the completed buttonette(s) to prevent them from pulling out of the eyelet.

ASSEMBLY

□ Step 15

- Rinse each piece in warm running water until the design is only slightly tacky.
- Place right side down on a non-stick surface to dry. This will help prevent curling.
- Parchment paper or a cooling rack work well to keep the lace from sticking to the surface.
- Dry completely.
- Once dry, press right side down on a Perfect Embroidery Press Cloth.



□ Step 16

- Optional: Use the OESD Mini MAT and Punch Tool with the 3mm attachment to create the eyelet indicated in the diagram. The eyelets are optional to hang the ornament charms from.
- Tip: Take care to not cut the satin stitching.
- Reference the Punch Tool Guide on page 21.

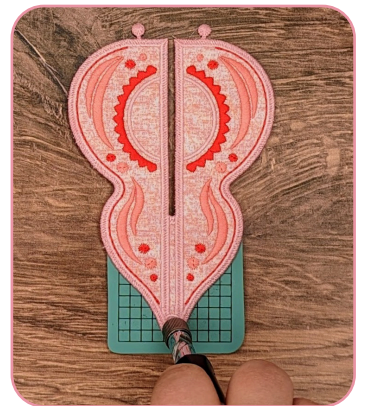

□ Step 17

- Slide Ornament 3 Section 2 FSA (12968-08) into Ornament 3 Section 1 FSA (12968-07).



ASSEMBLY

□ Step 18

- Match the eyelets of the square lace piece of Ornament 3 Cap FSL (12968-09) to the buttonettes of the ornament sections. Pull the buttonettes through the corresponding eyelets.



□ Step 19

- Match the eyelets of the cross shaped ornament top to the square lace piece.
- Pull the eyelets through the corresponding buttonettes.



□ Step 20

- Use OESD Alligator Clamps to insert a ribbon through the top of the ornament cap.
- Optional: Use ribbon to attach an Ornament Charm to the punched eyelet.

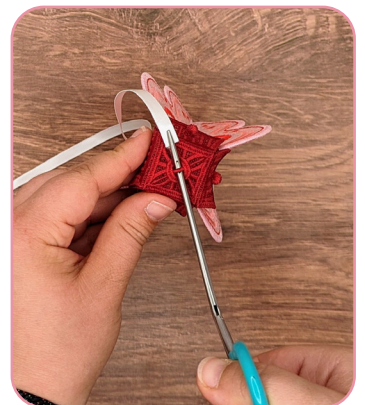

ASSEMBLY

□ Step 21

- The project is complete. Enjoy!



PUNCH TOOL GUIDES



12968-01

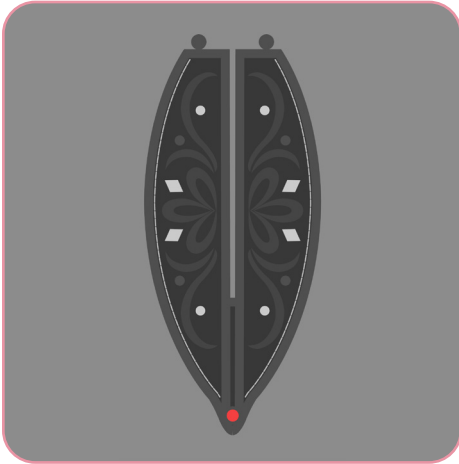

12968-04

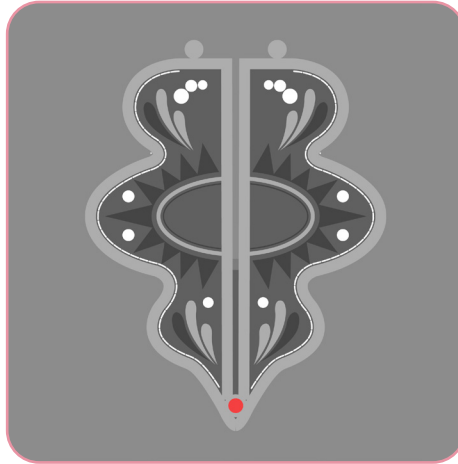

12968-07

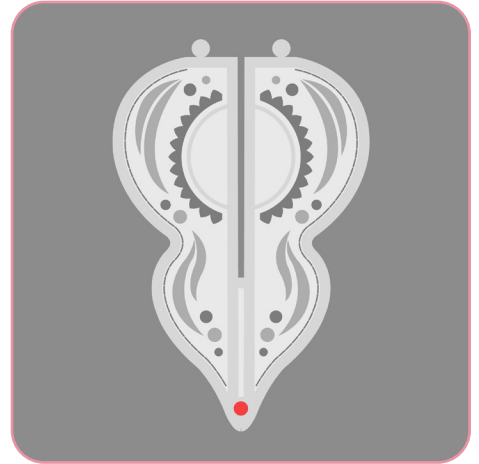

12968-10



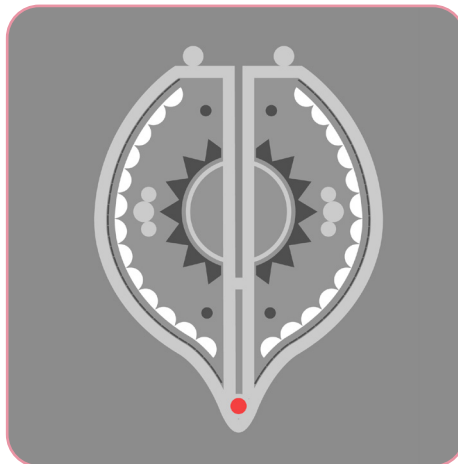

12968-13

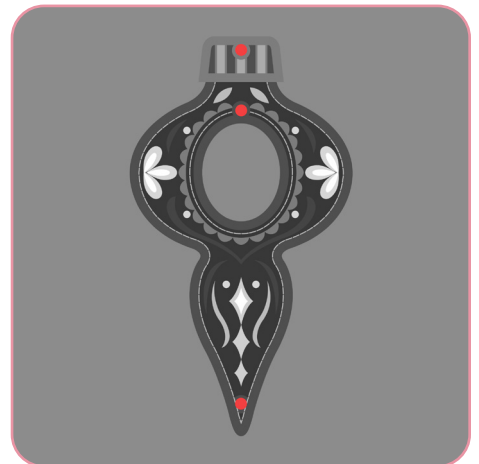

12968-16



 = 2 MM

 = 3 MM

 = 4 MM

CRAFT KNIFE



PUNCH TOOL GUIDES



12968-17

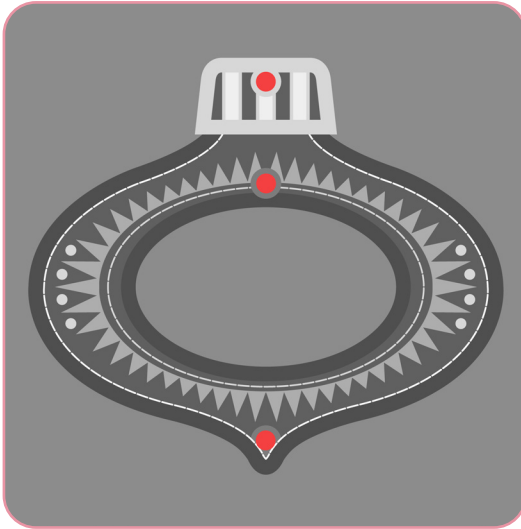

12968-18

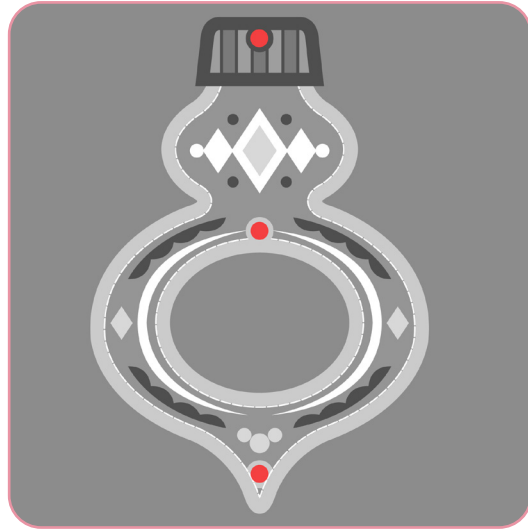

12968-19

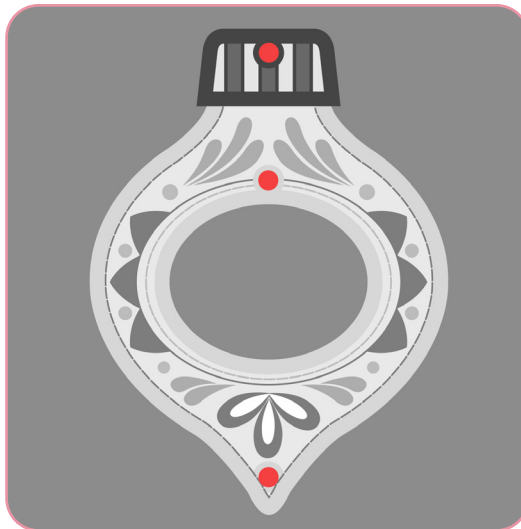

12968-20

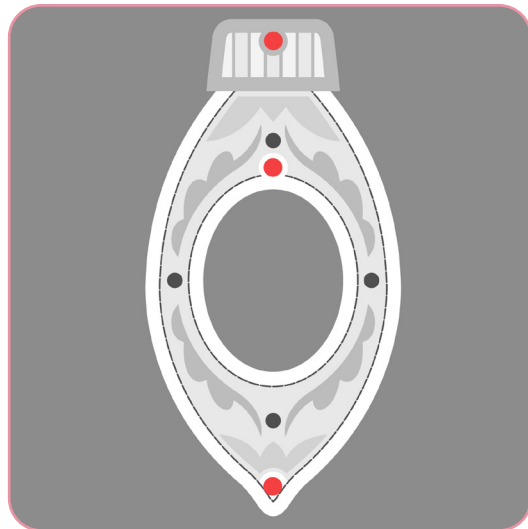

● = 2 MM

● = 3 MM

● = 4 MM

CRAFT KNIFE



ATTENTION

When printing this document, any page scaling or page fitting options in your print dialog box must be turned OFF or set to NONE so that your files will print out at their actual size. Images not printed at actual size will not function as intended.

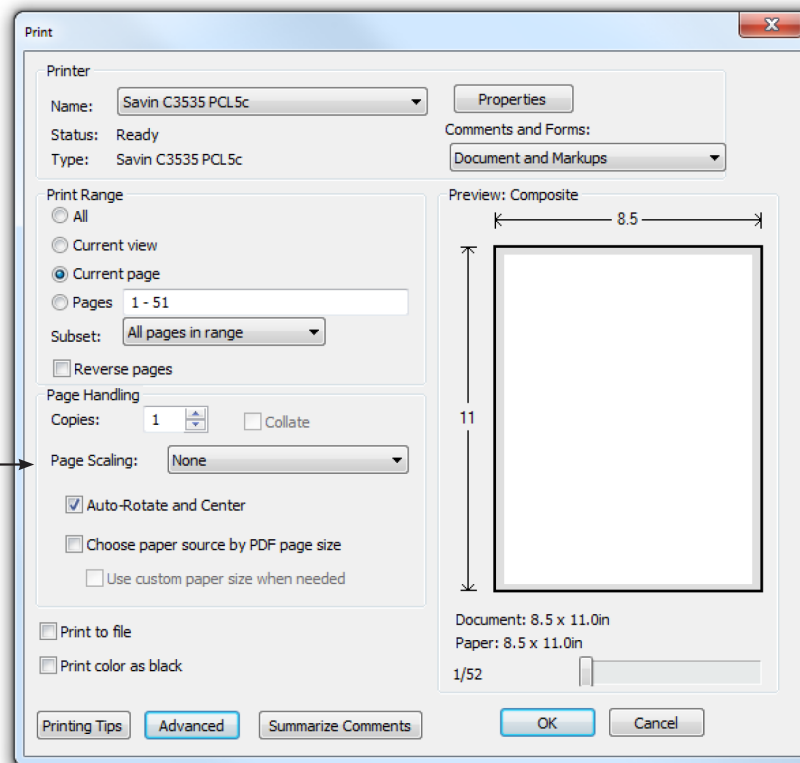

TO SAVE PAPER

Only print the desired image by navigating to the image's page, go to File > Print and select "Current page" in the print dialog box. Repeat for each desired image.

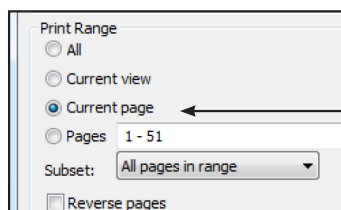

APPLIQUE PATTERNS



Print at 100%. No scaling. This box measures 1" x 1". Use the box as an accuracy guide when printing templates.

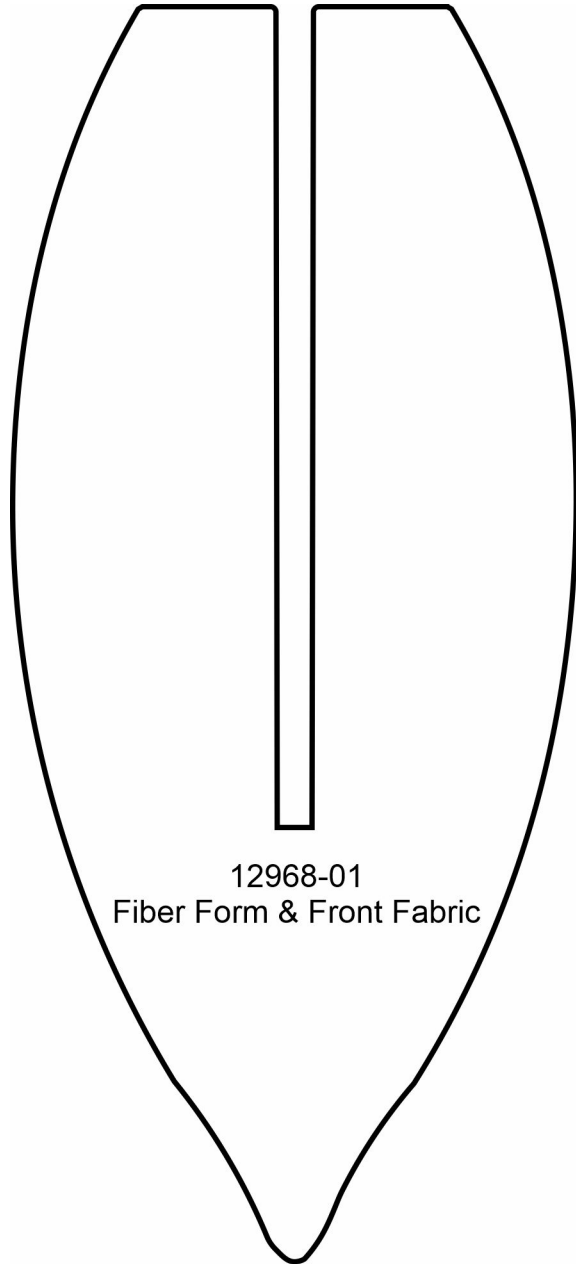

12968-01
Fiber Form & Front Fabric

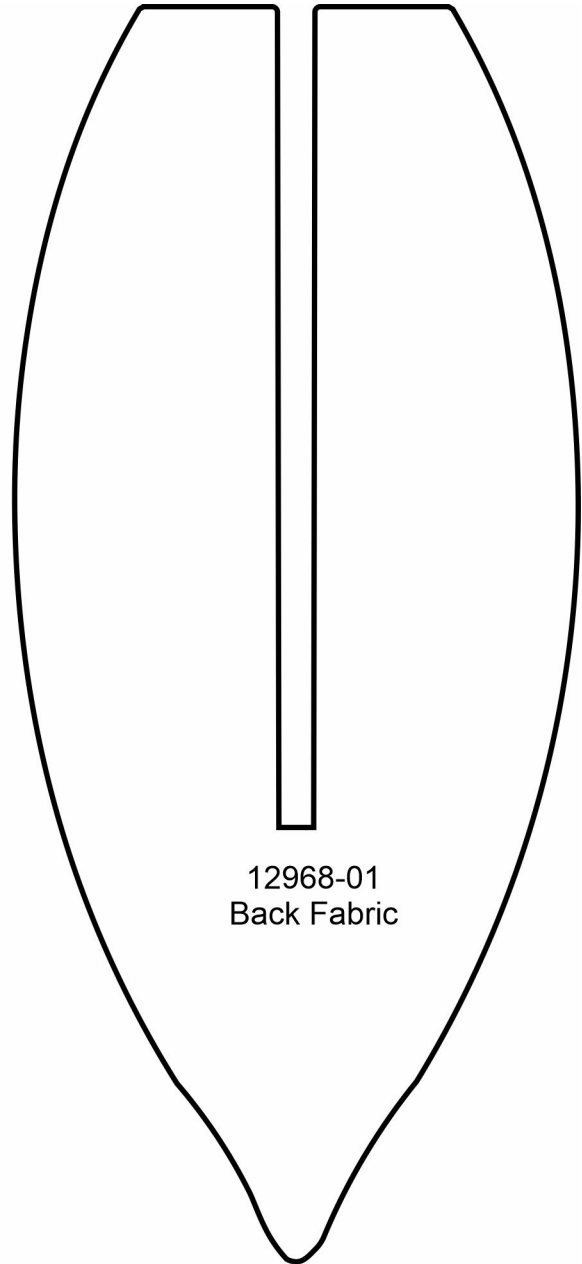

12968-01
Back Fabric

APPLIQUE PATTERNS



Print at 100%. No scaling. This box measures 1" x 1". Use the box as an accuracy guide when printing templates.

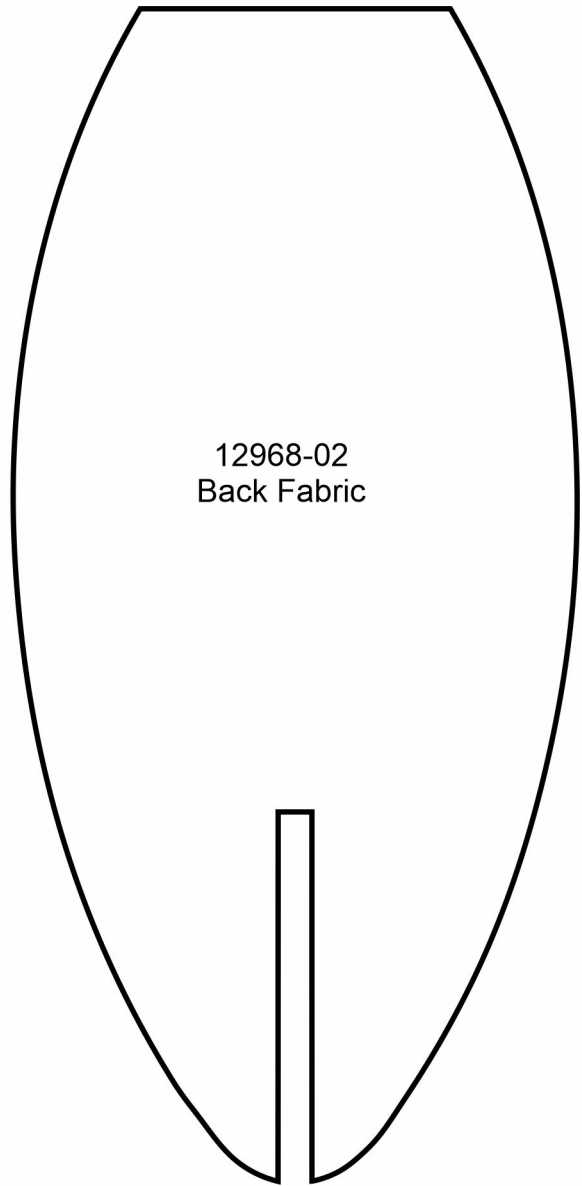
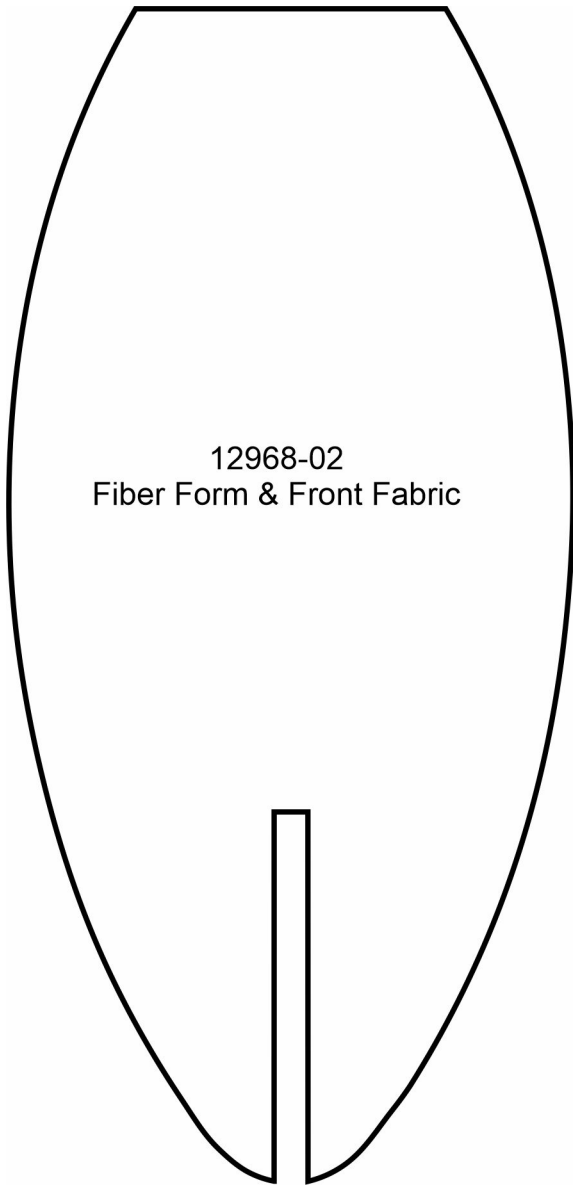

APPLIQUE PATTERNS

Print at 100%. No scaling. This box measures 1" x 1". Use the box as an accuracy guide when printing templates.

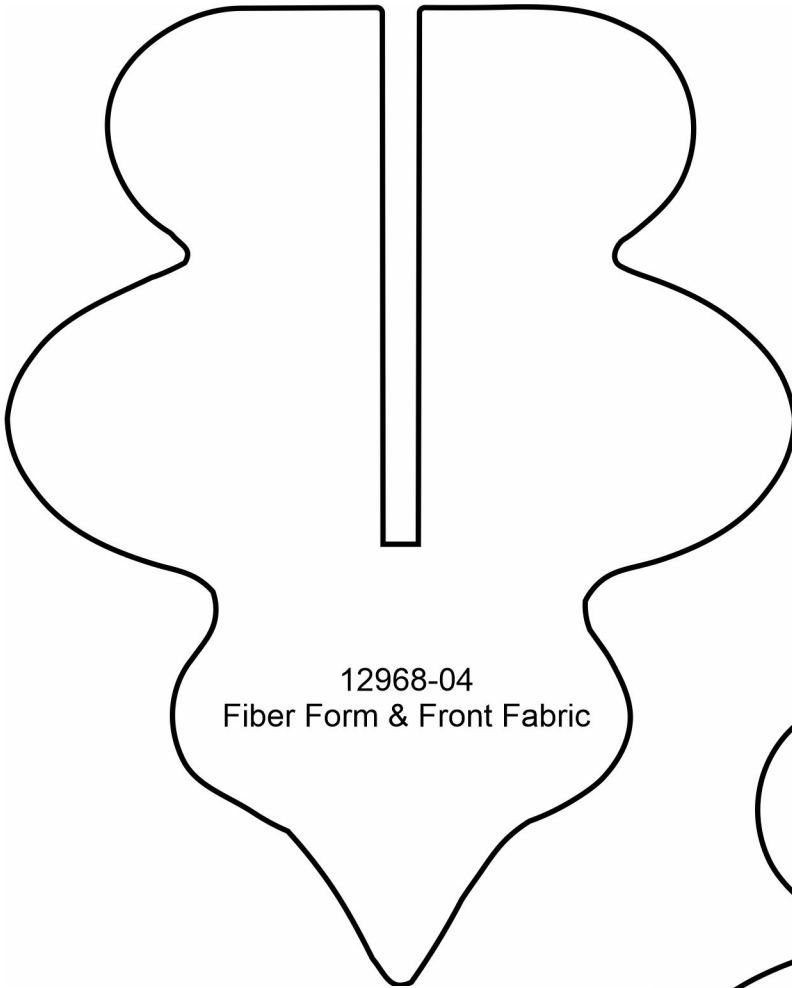

12968-04
Fiber Form & Front Fabric

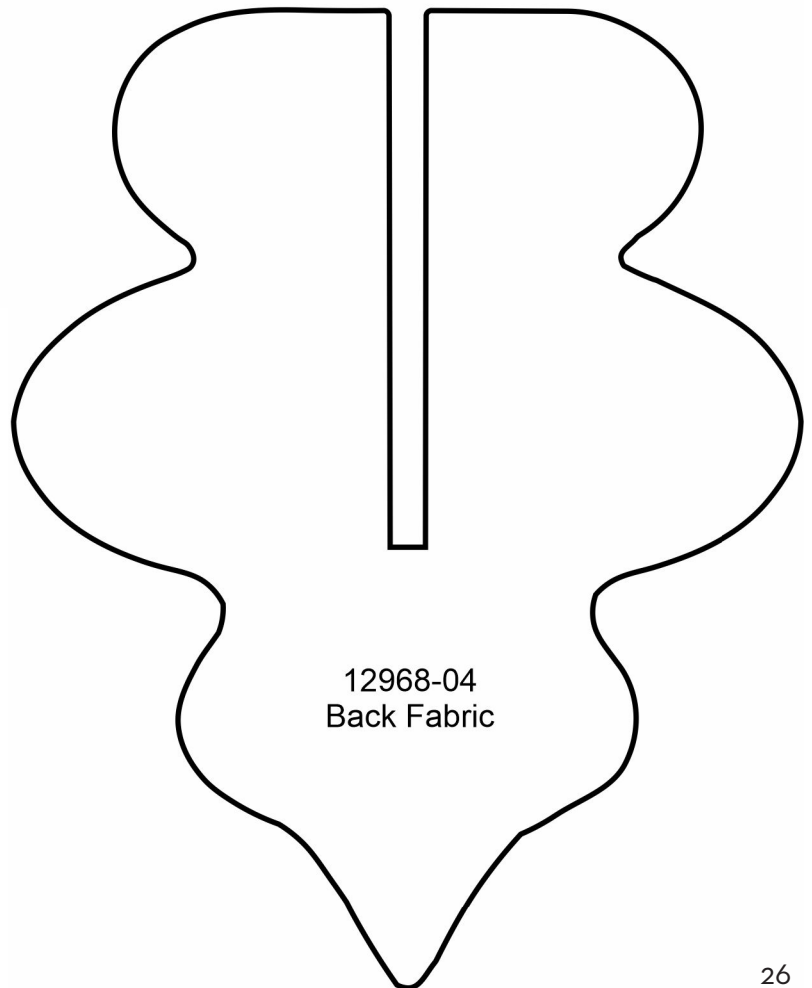

12968-04
Back Fabric

APPLIQUE PATTERNS

Print at 100%. No
scaling. This box
measures 1" x 1".
Use the box as an
accuracy guide
when printing
templates.

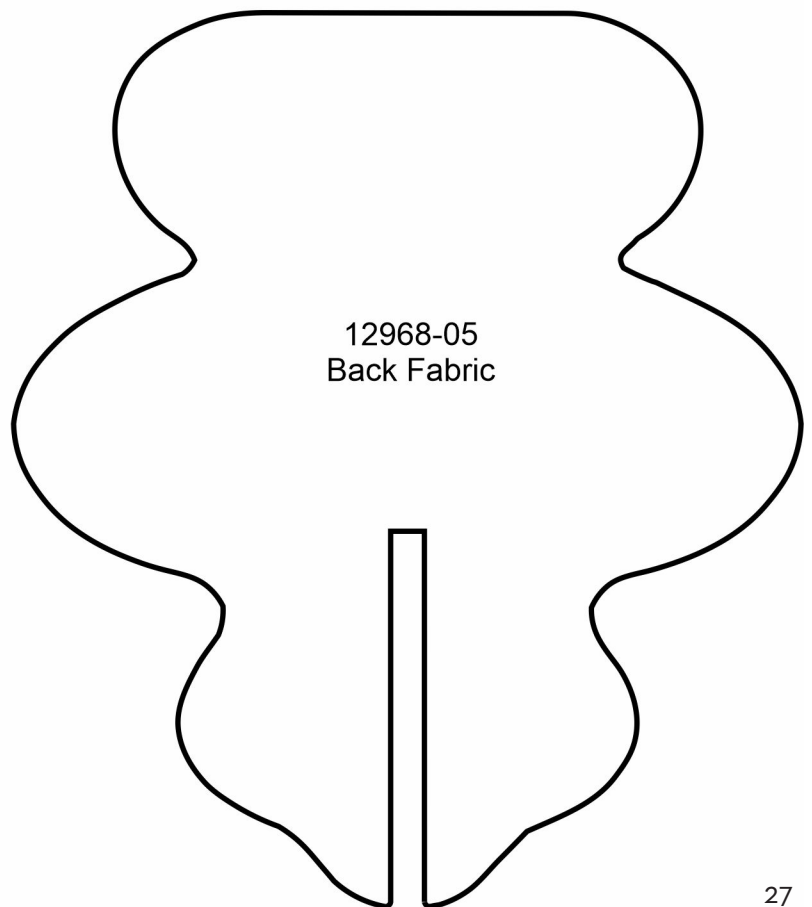
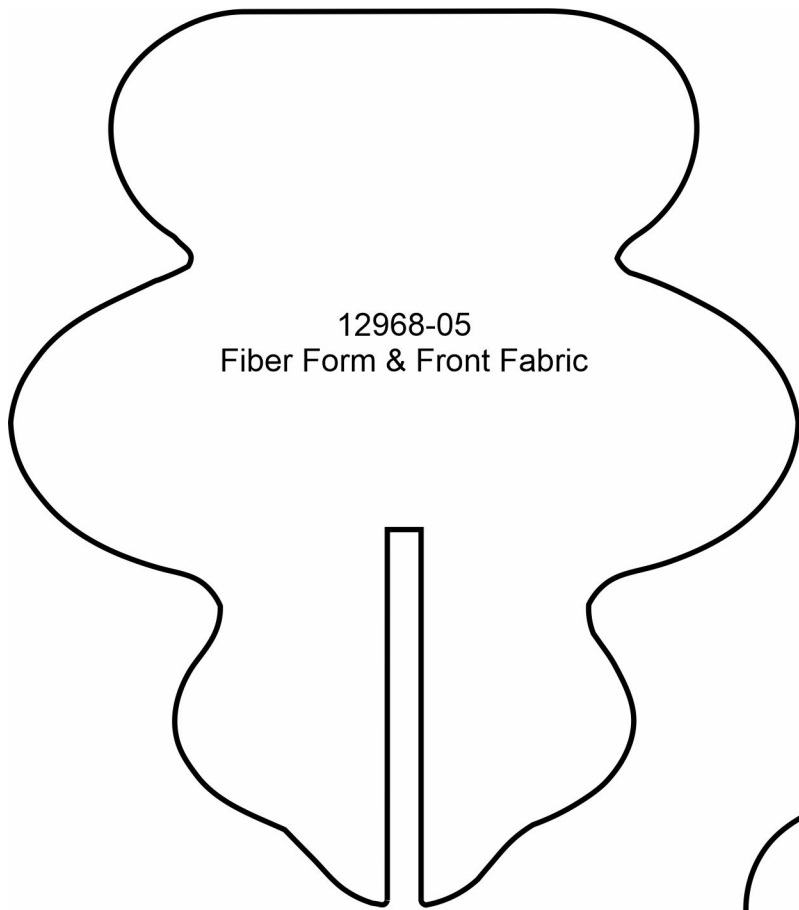

APPLIQUE PATTERNS

Print at 100%. No scaling. This box measures 1" x 1". Use the box as an accuracy guide when printing templates.

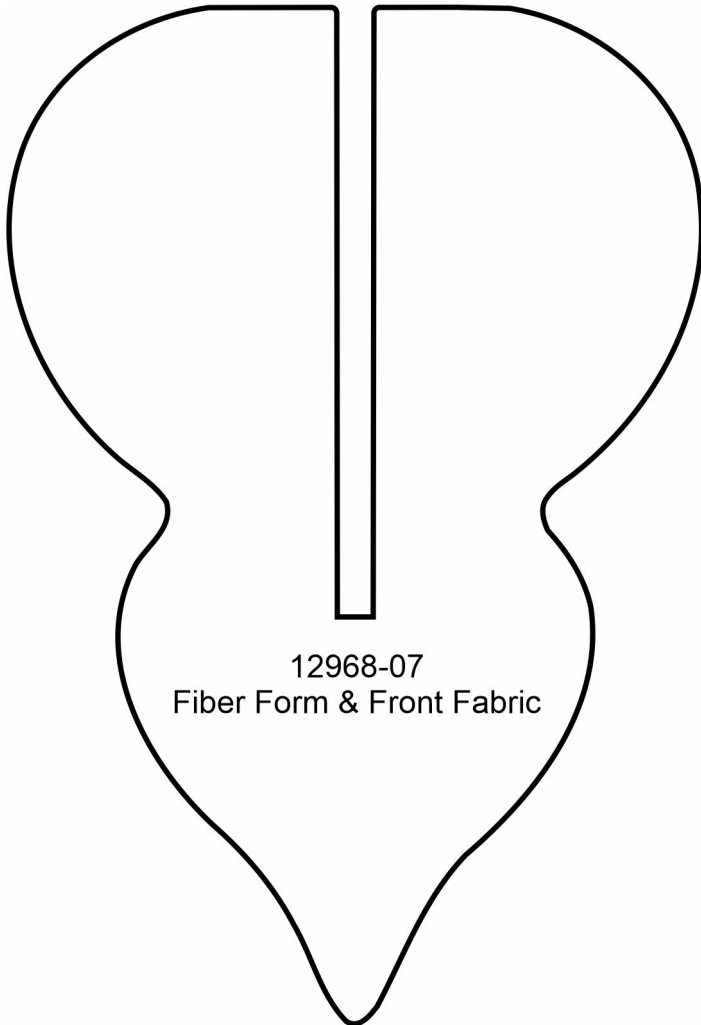

12968-07
Fiber Form & Front Fabric

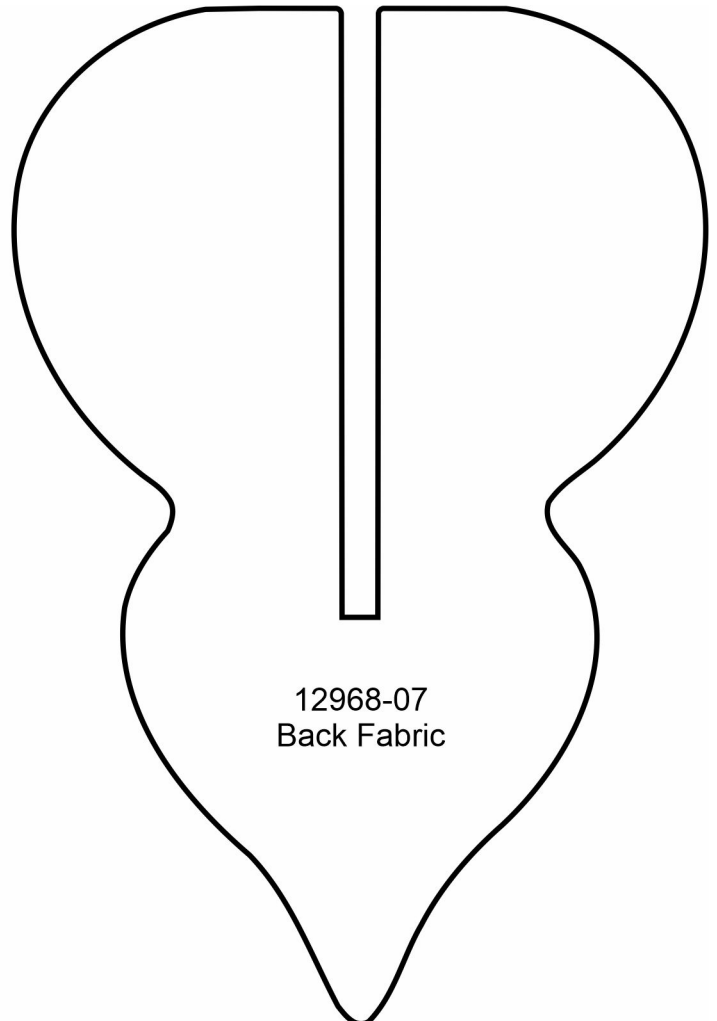

12968-07
Back Fabric

APPLIQUE PATTERNS

Print at 100%. No
scaling. This box
measures 1" x 1".
Use the box as an
accuracy guide
when printing
templates.

12968-08
Fiber Form & Front Fabric

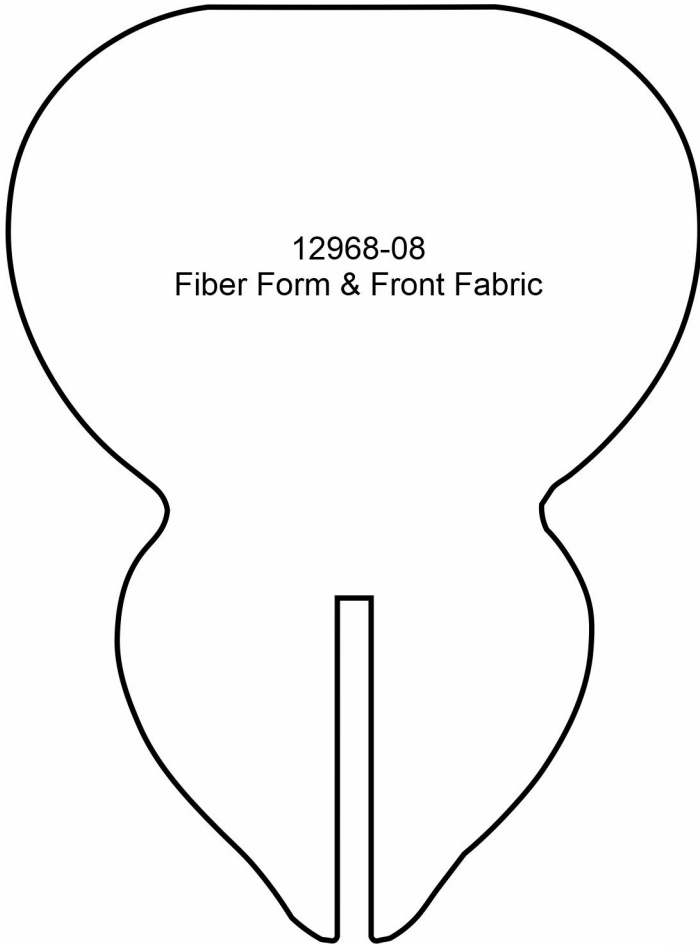

12968-08
Back Fabric

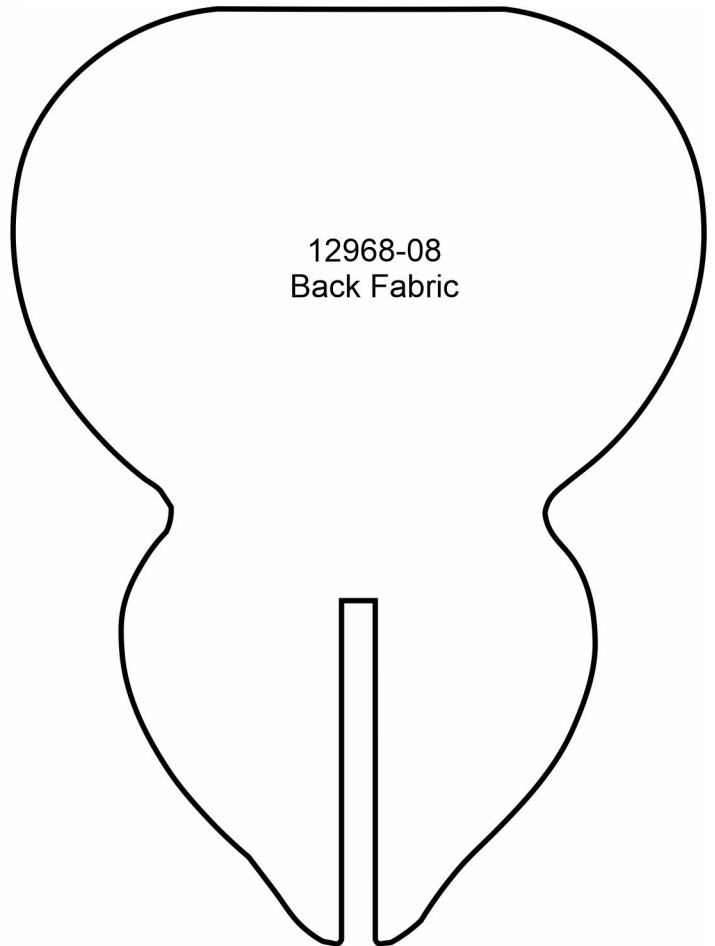

APPLIQUE PATTERNS

Print at 100%. No scaling. This box measures 1" x 1". Use the box as an accuracy guide when printing templates.

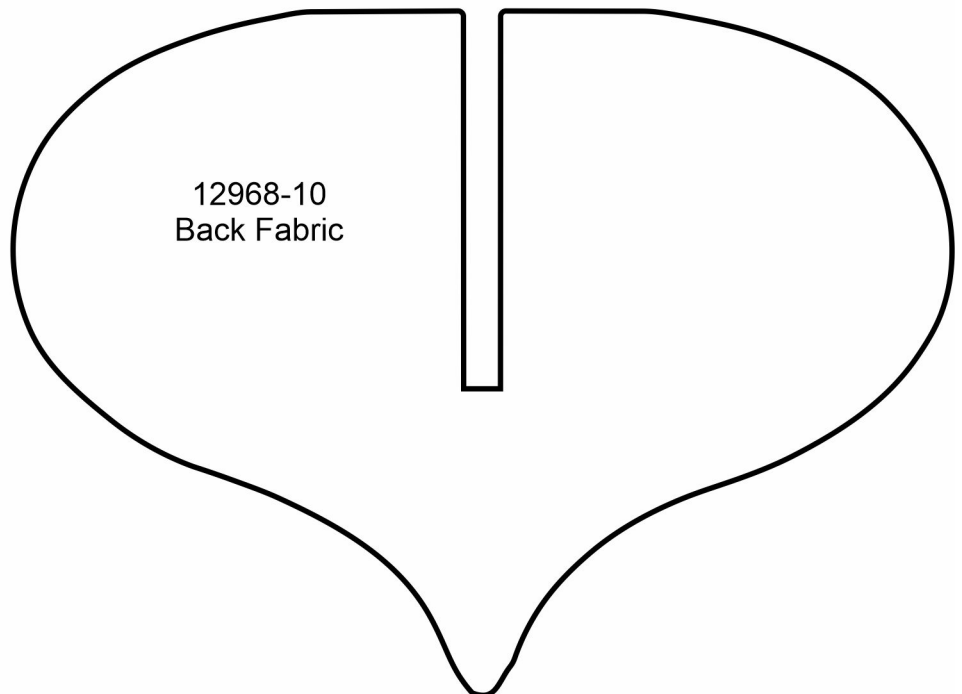
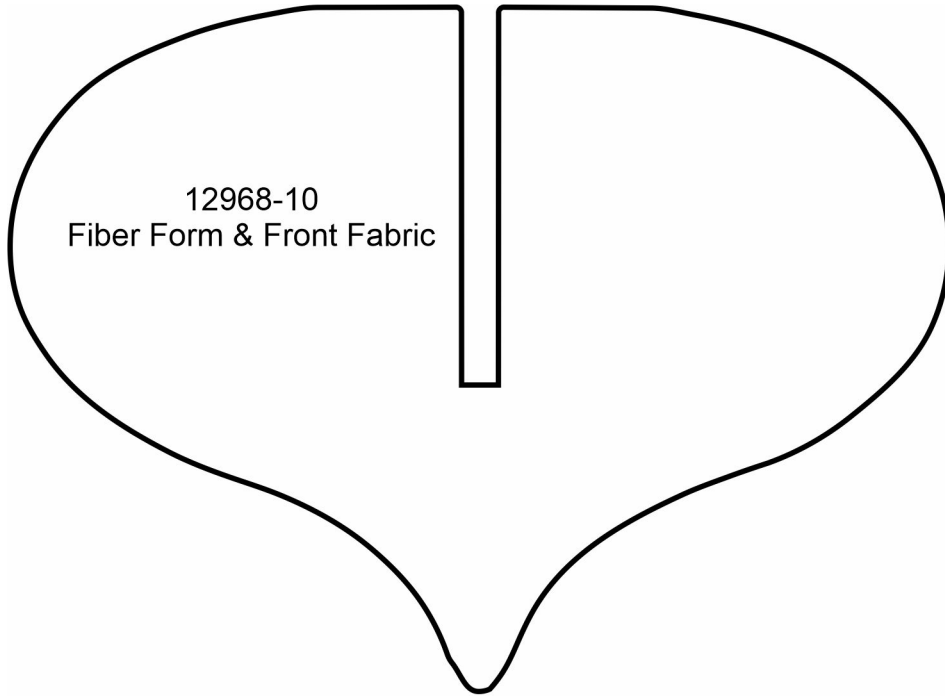

APPLIQUE PATTERNS



Print at 100%. No scaling. This box measures 1" x 1". Use the box as an accuracy guide when printing templates.

12968-11
Fiber Form & Front Fabric

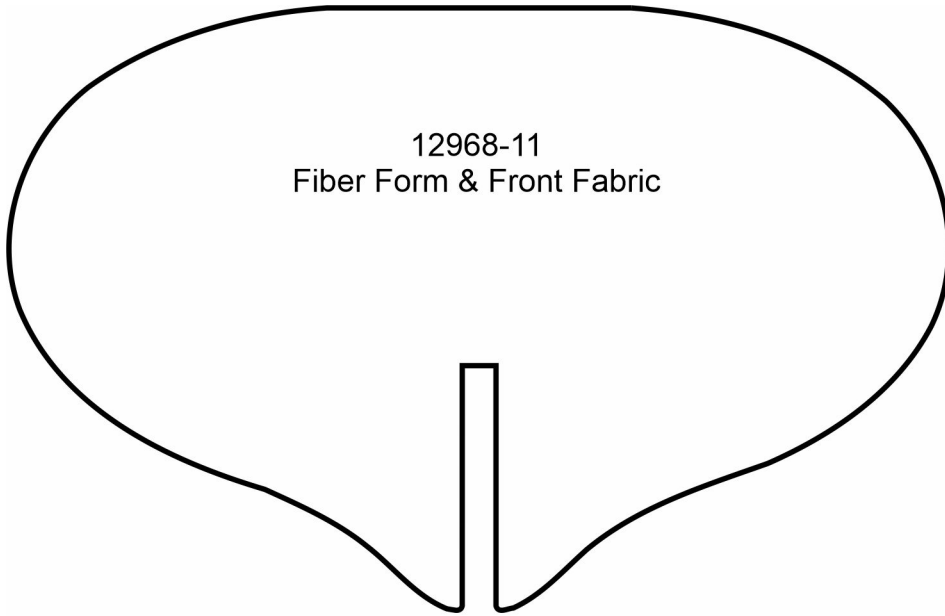

12968-11
Back Fabric

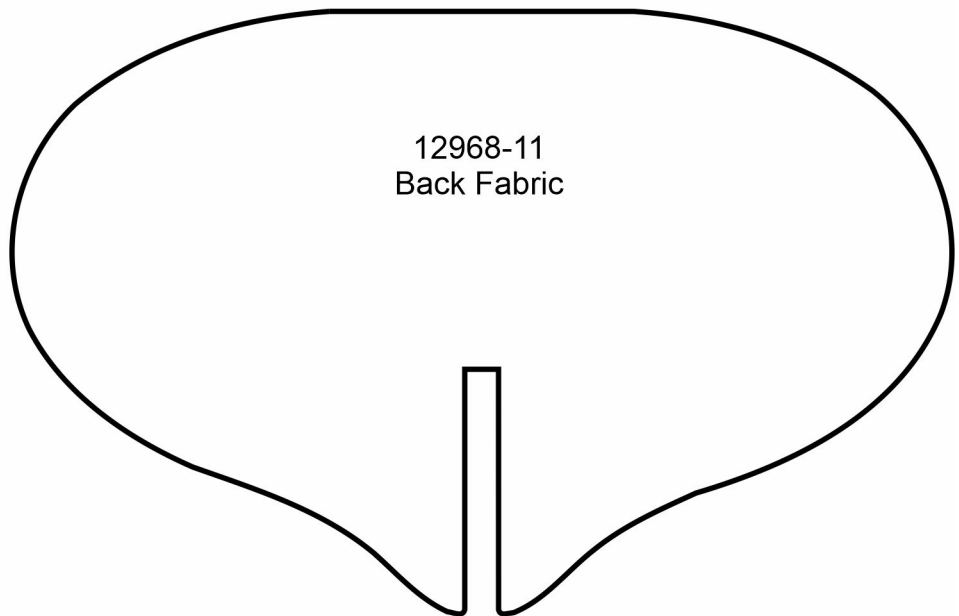

APPLIQUE PATTERNS

Print at 100%. No scaling. This box measures 1" x 1". Use the box as an accuracy guide when printing templates.

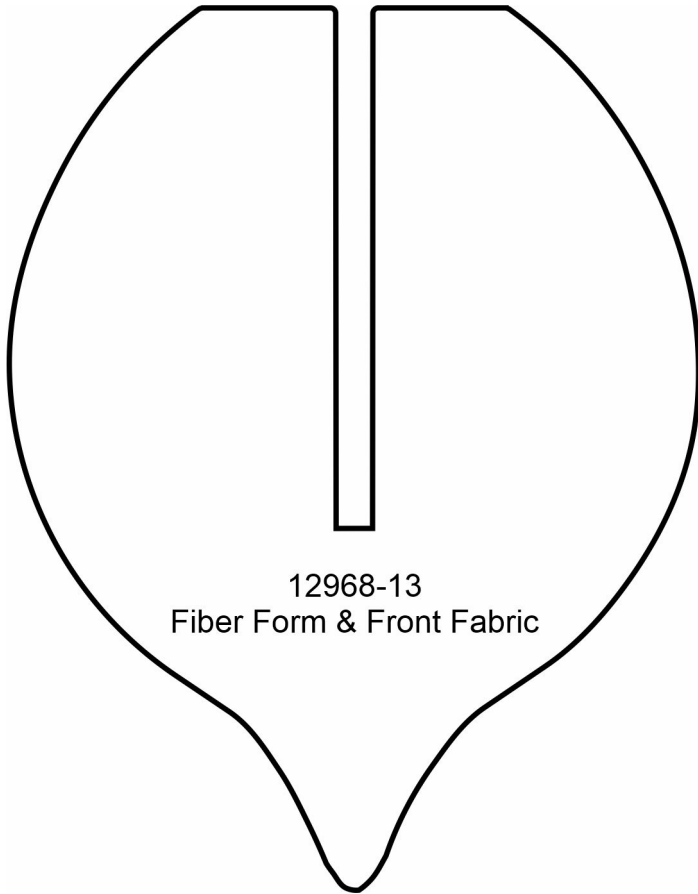

12968-13
Fiber Form & Front Fabric

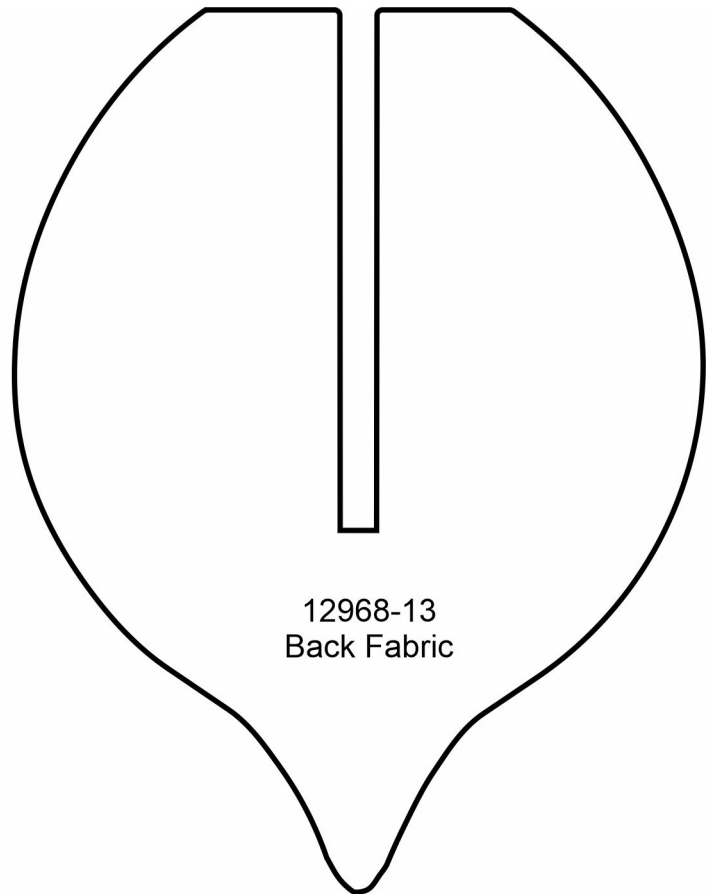

12968-13
Back Fabric

APPLIQUE PATTERNS

Print at 100%. No
scaling. This box
measures 1" x 1".
Use the box as an
accuracy guide
when printing
templates.

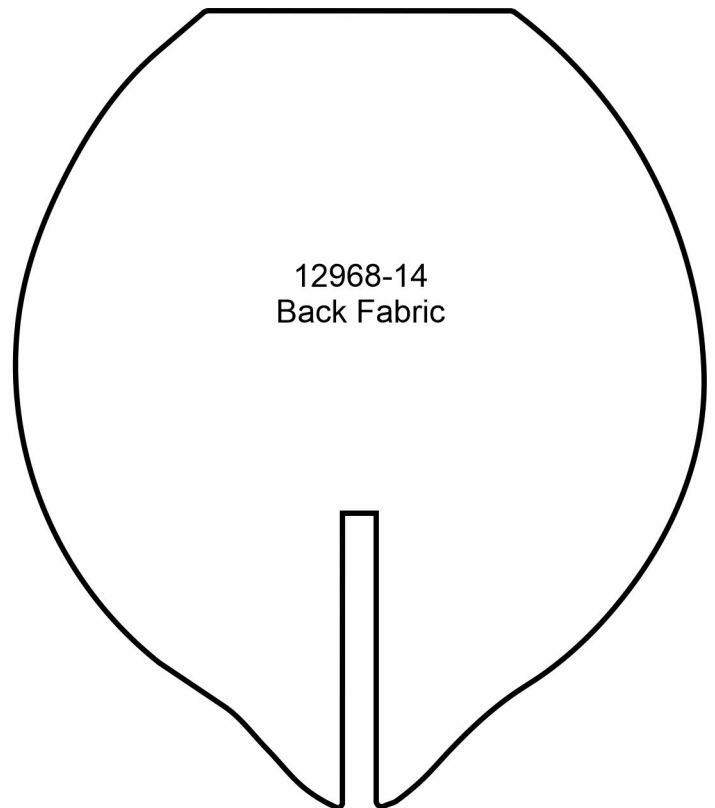
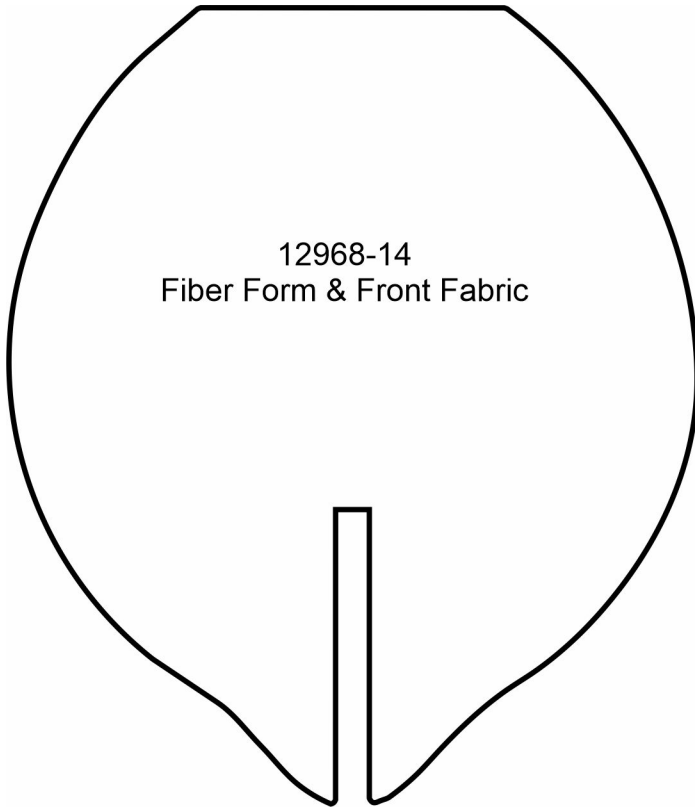

APPLIQUE PATTERNS

Print at 100%. No scaling. This box measures 1" x 1". Use the box as an accuracy guide when printing templates.

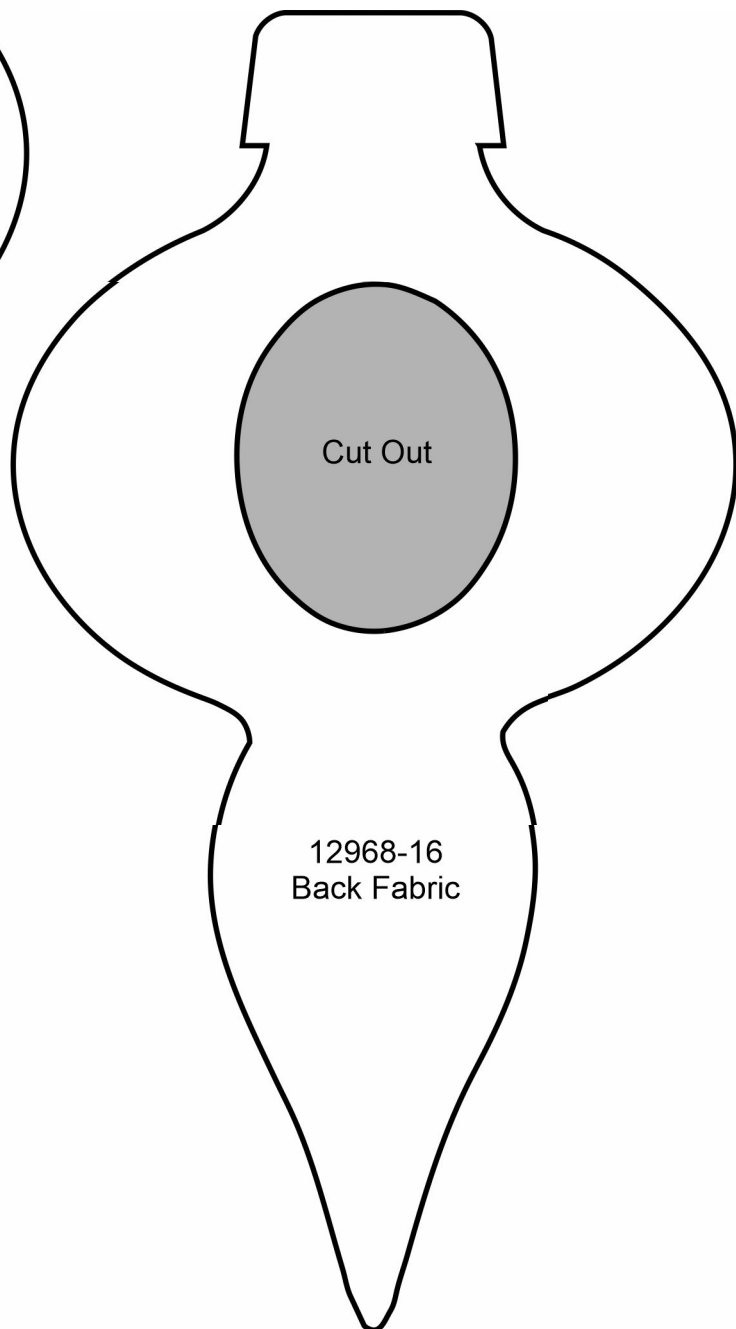
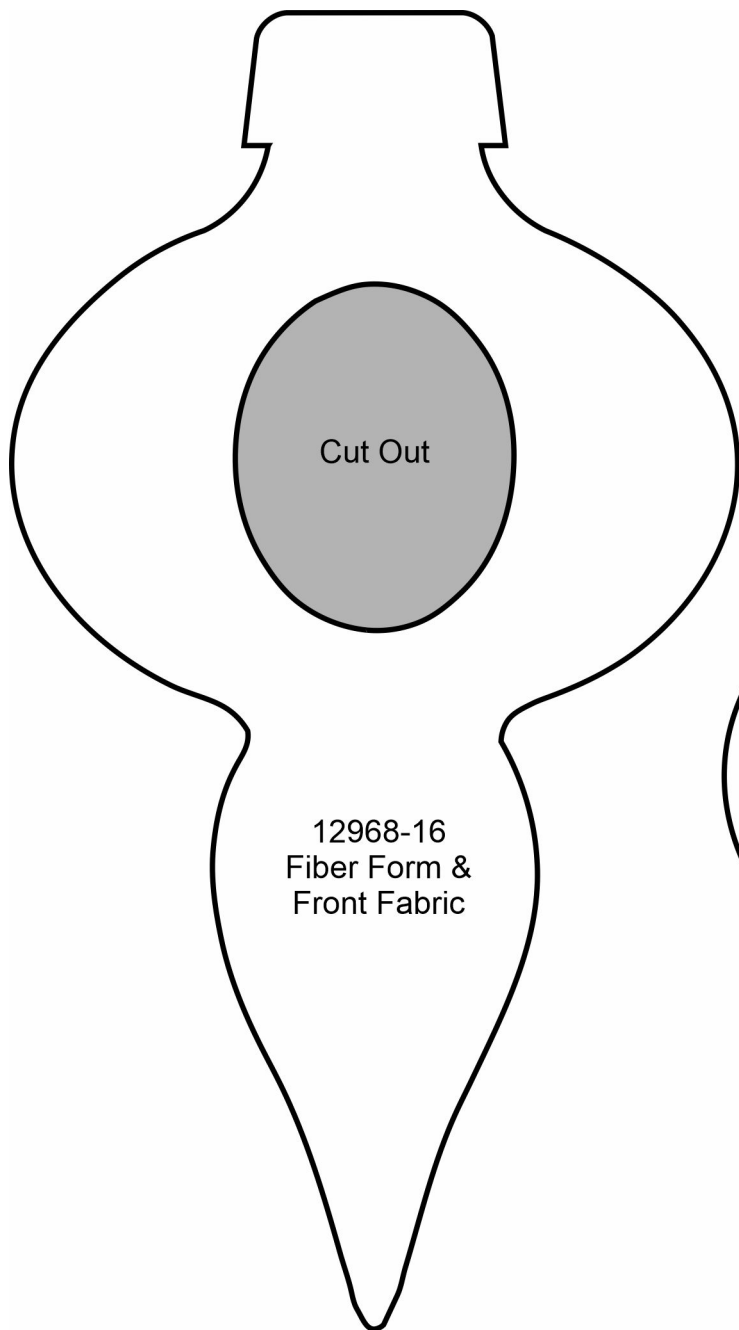

APPLIQUE PATTERNS

Print at 100%. No scaling. This box measures 1" x 1". Use the box as an accuracy guide when printing templates.

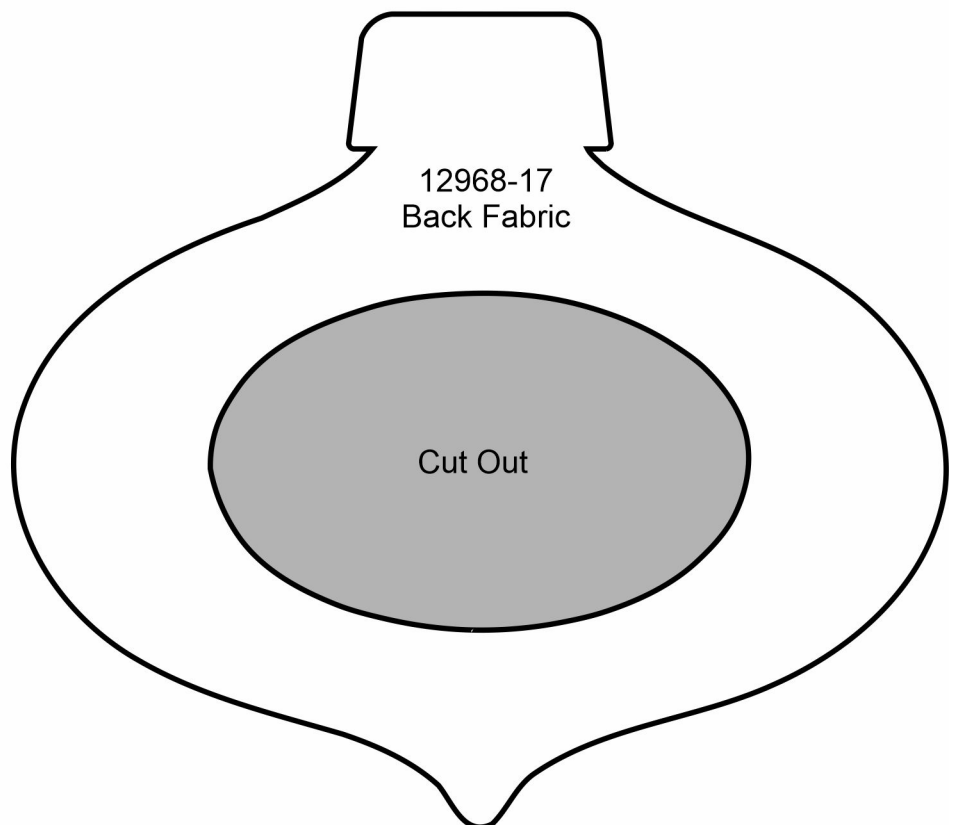
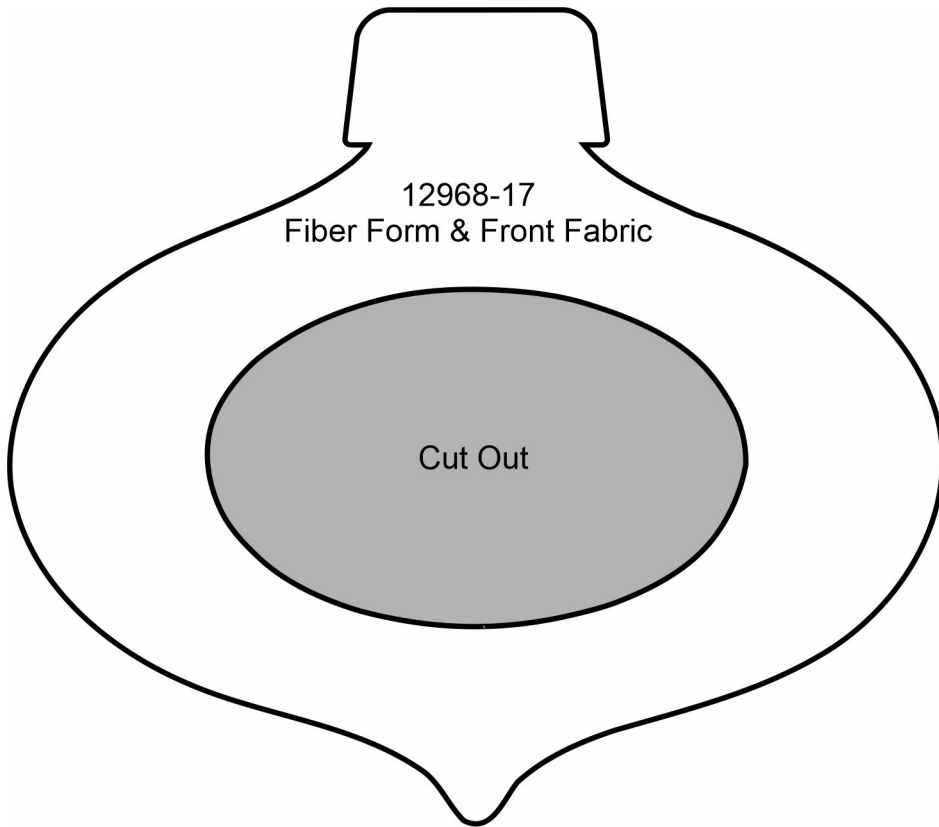

APPLIQUE PATTERNS

Print at 100%. No scaling. This box measures 1" x 1". Use the box as an accuracy guide when printing templates.

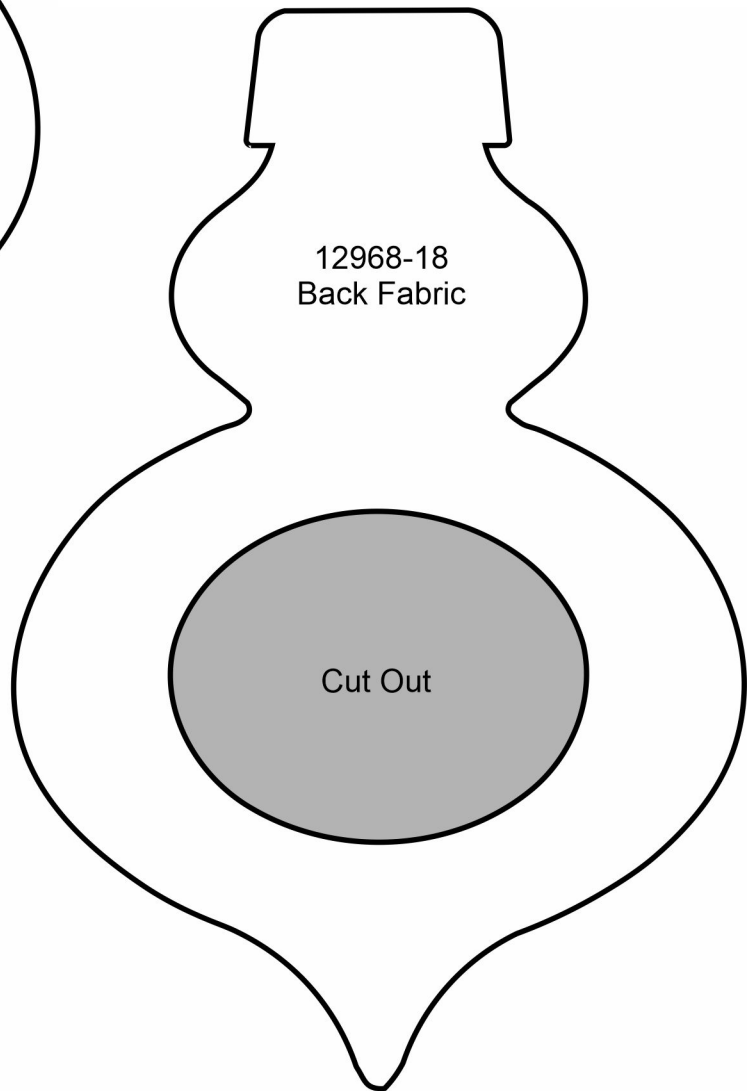
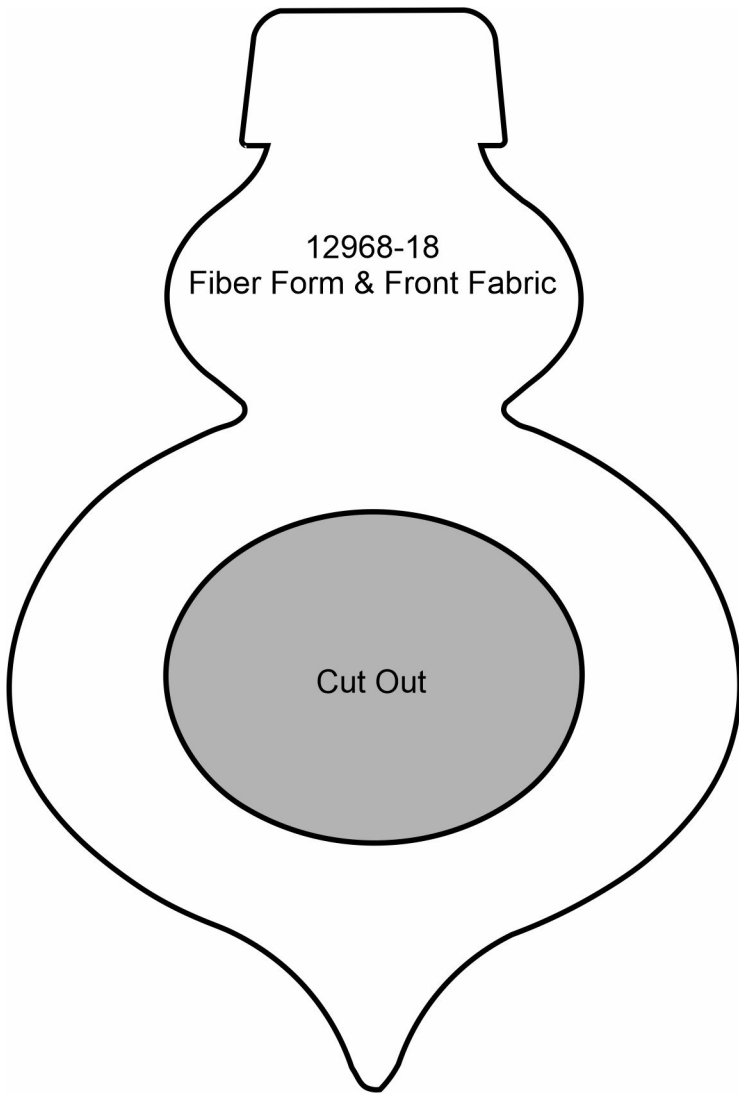

APPLIQUE PATTERNS

Print at 100%. No scaling. This box measures 1" x 1". Use the box as an accuracy guide when printing templates.

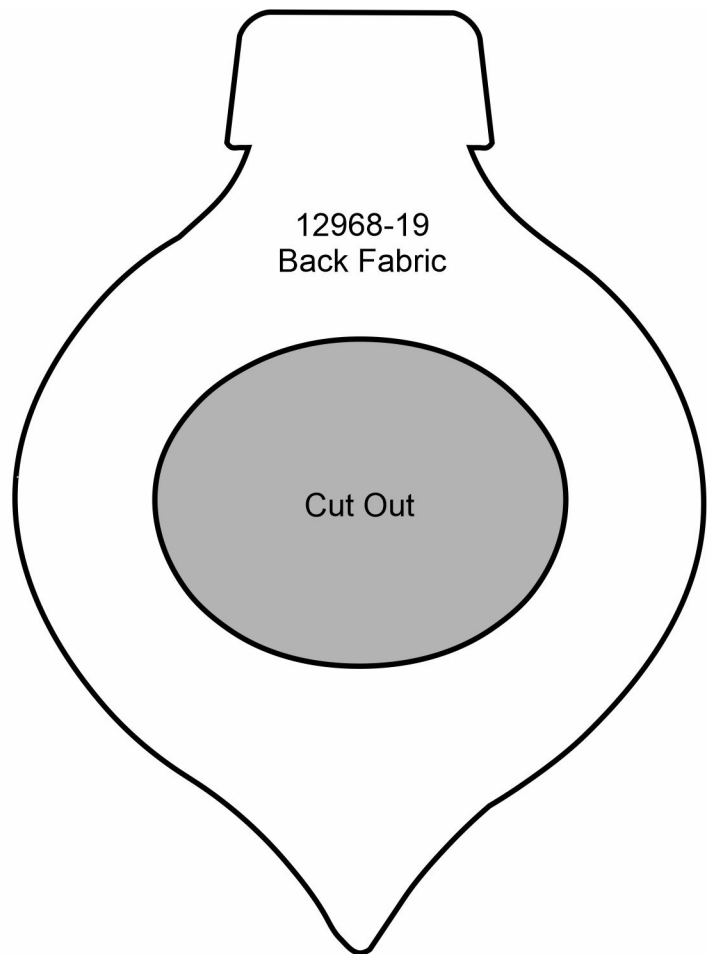
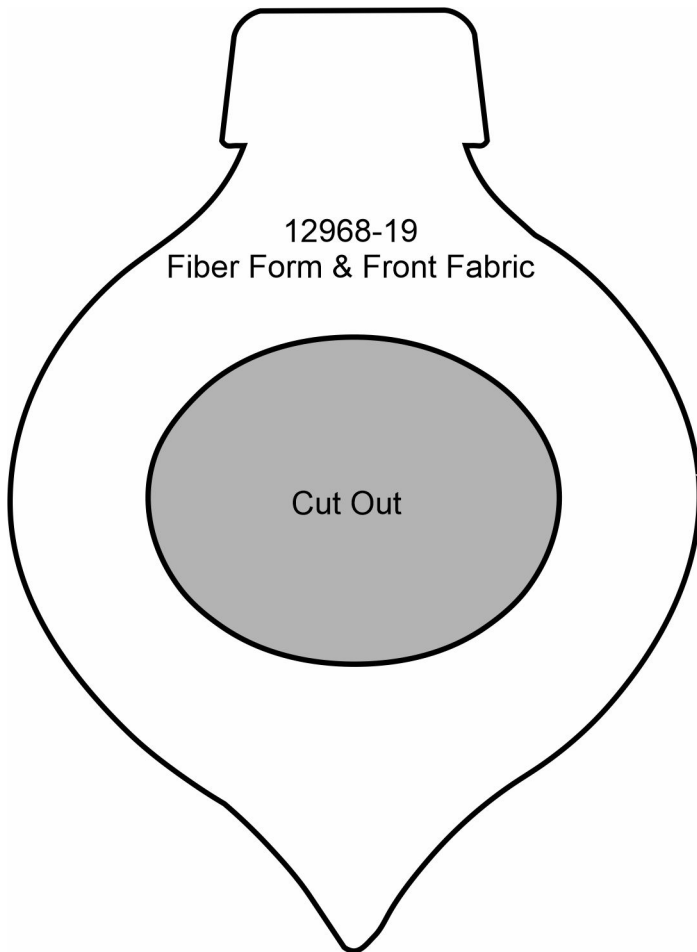

APPLIQUE PATTERNS

Print at 100%. No scaling. This box measures 1" x 1". Use the box as an accuracy guide when printing templates.

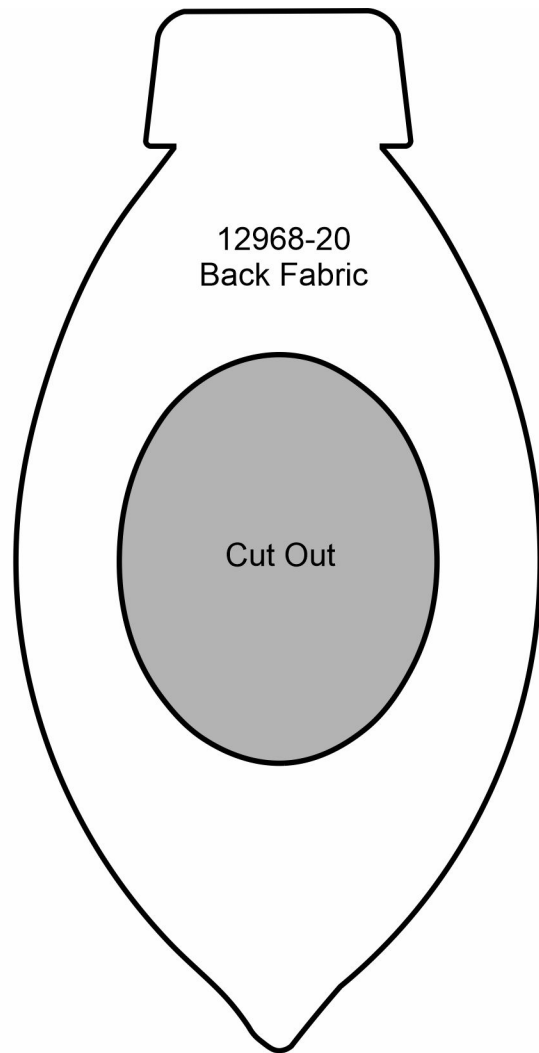
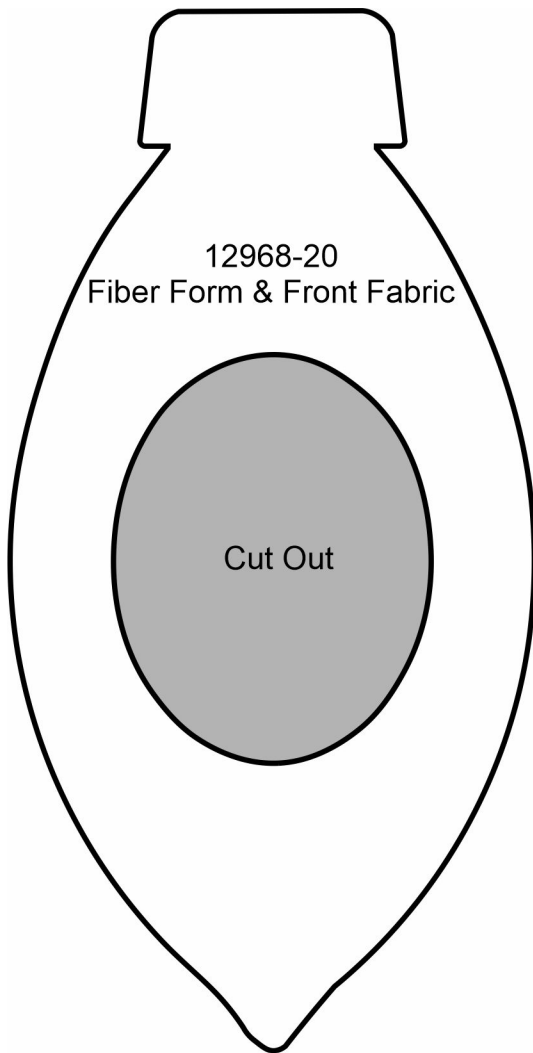

MIRRORED PATTERNS PREMIER COLLECTION

Print at 100%. No scaling. This box measures 1" x 1". Use the box as an accuracy guide when printing templates.

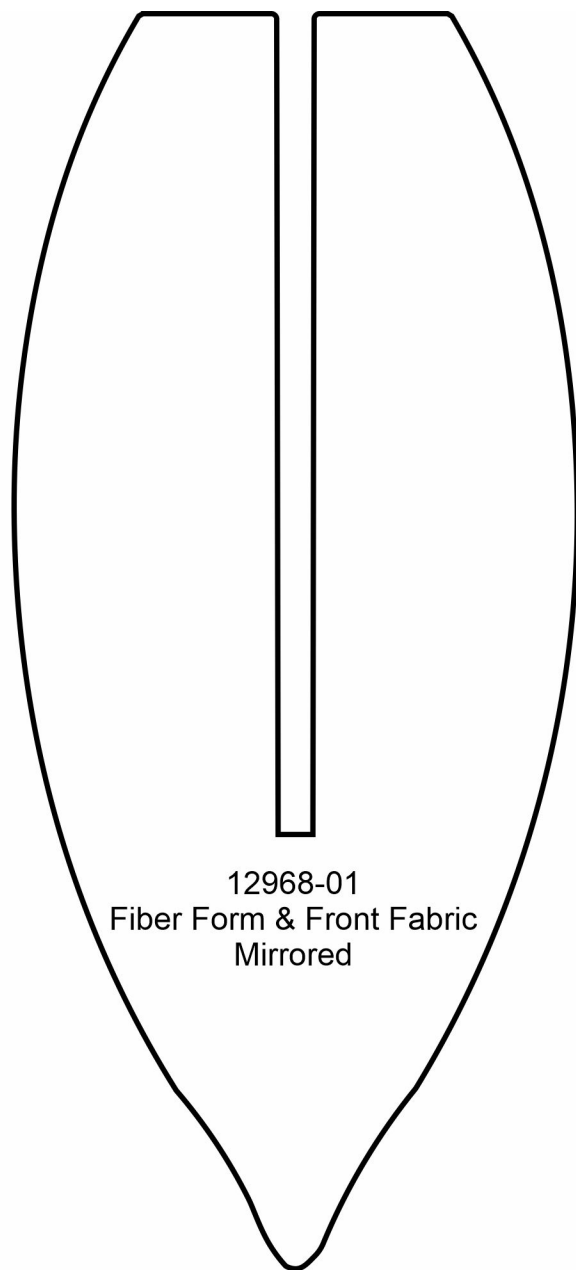
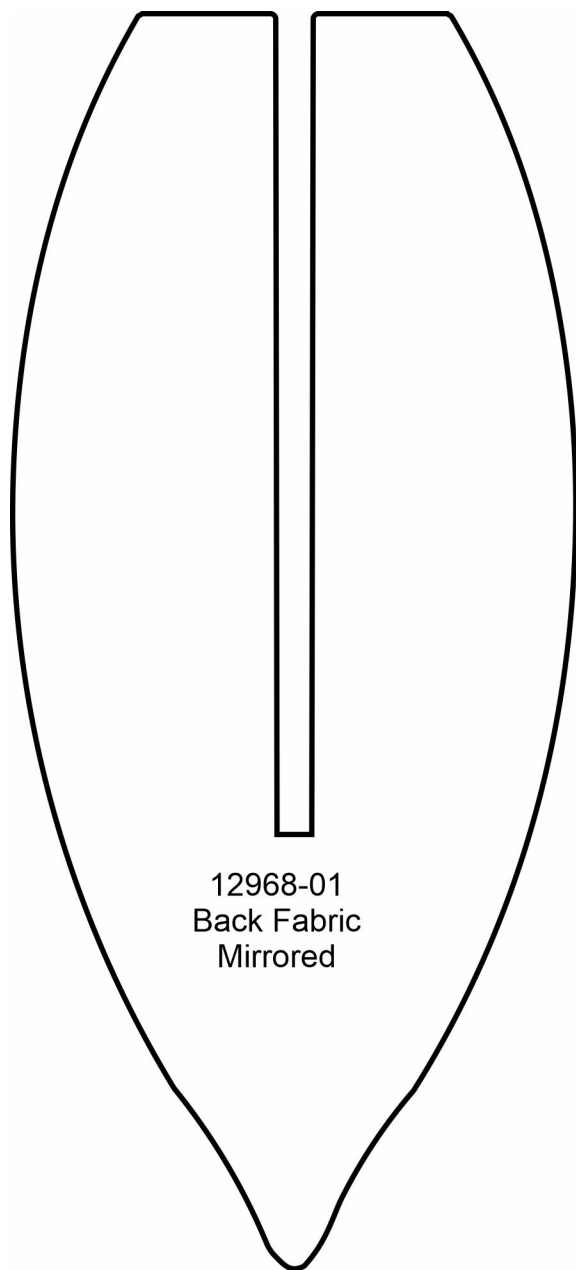

MIRRORED PATTERNS



Print at 100%. No scaling. This box measures 1" x 1". Use the box as an accuracy guide when printing templates.

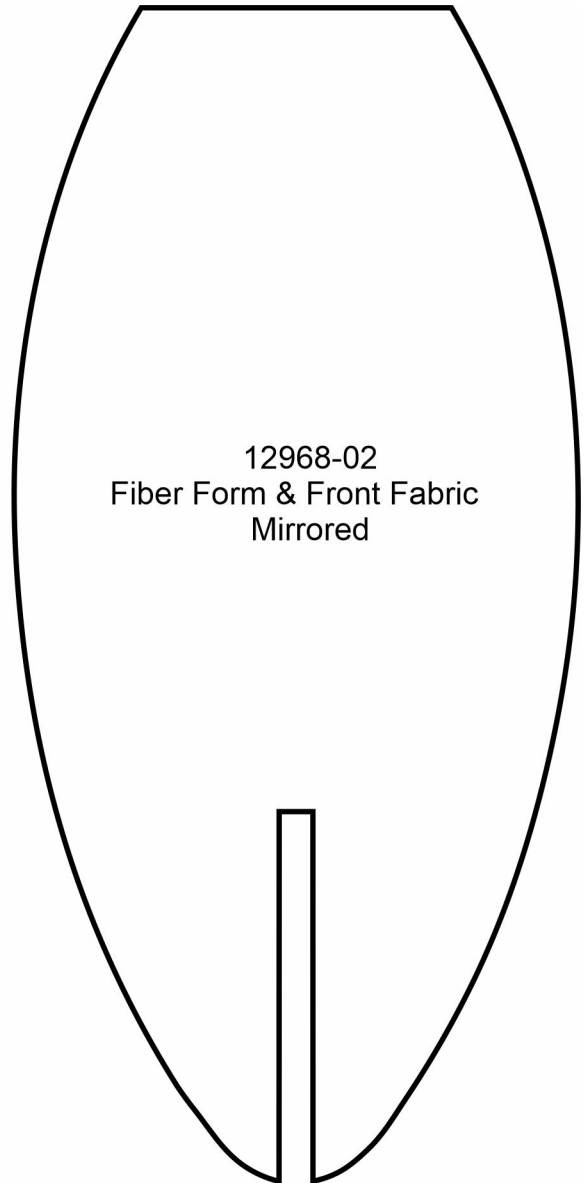
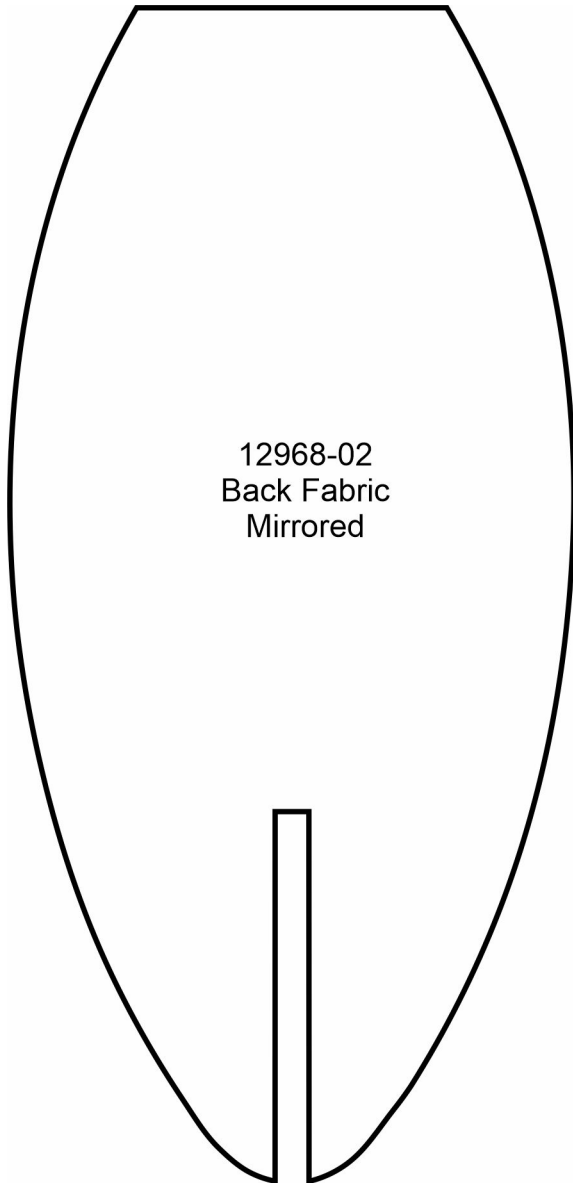

MIRRORED PATTERNS

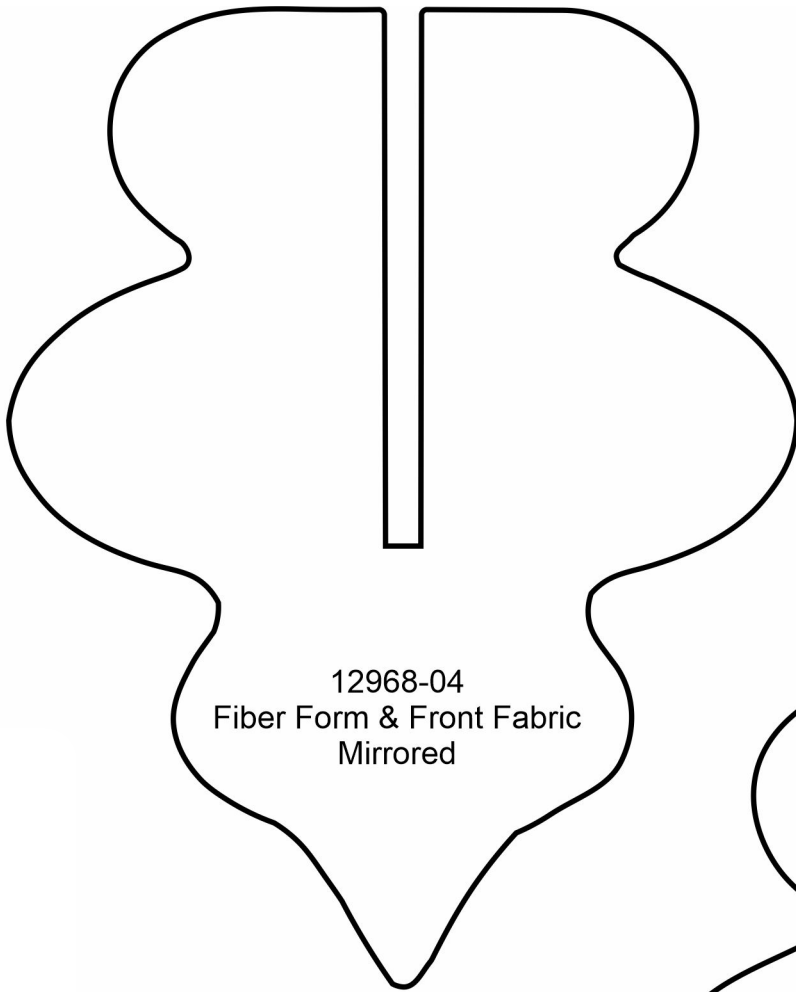

12968-04
Fiber Form & Front Fabric
Mirrored

Print at 100%. No scaling. This box measures 1" x 1". Use the box as an accuracy guide when printing templates.

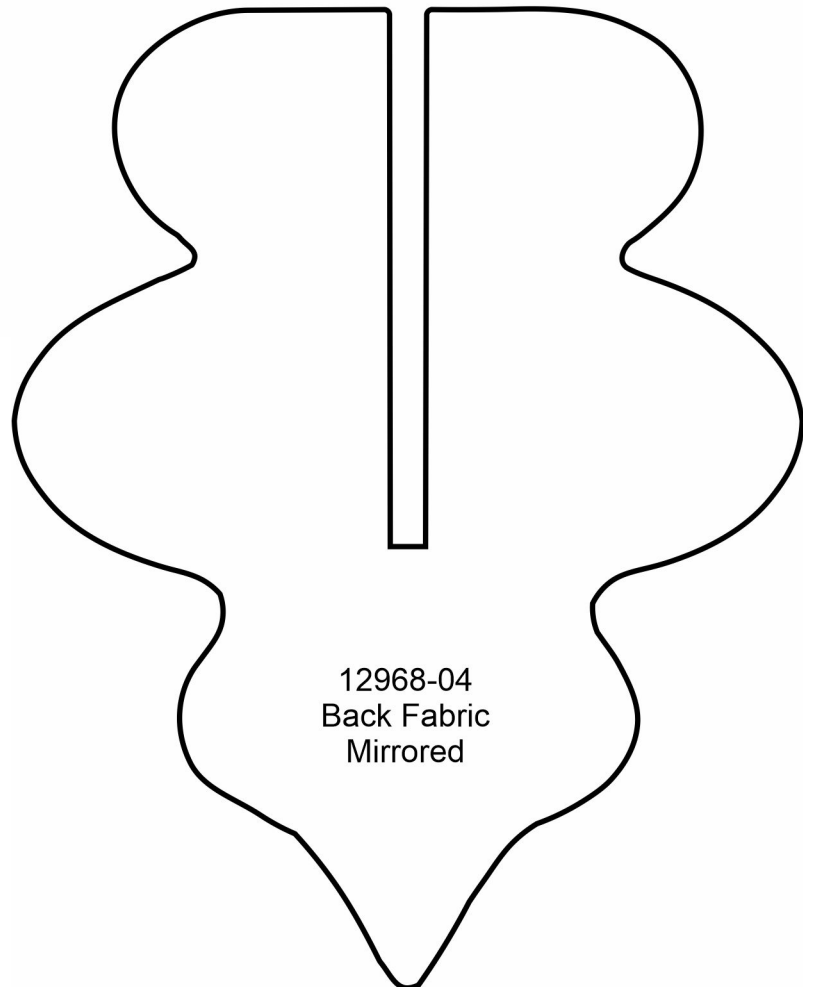

12968-04
Back Fabric
Mirrored

MIRRORED PATTERNS PREMIER COLLECTION

Print at 100%. No scaling. This box measures 1" x 1". Use the box as an accuracy guide when printing templates.

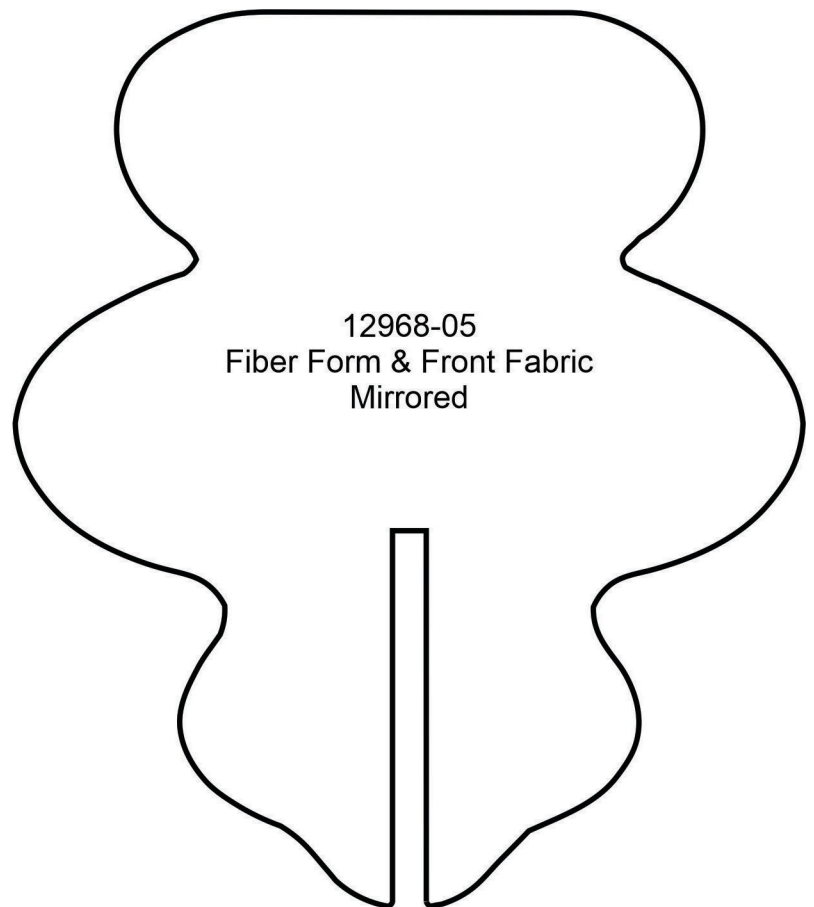
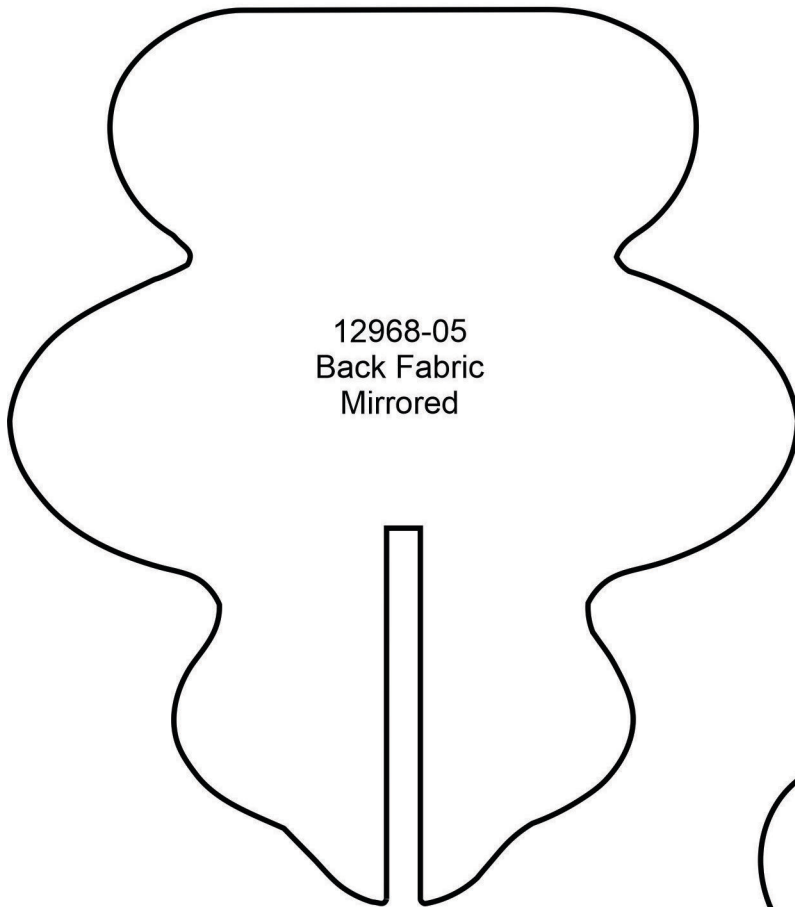

MIRRORED PATTERNS

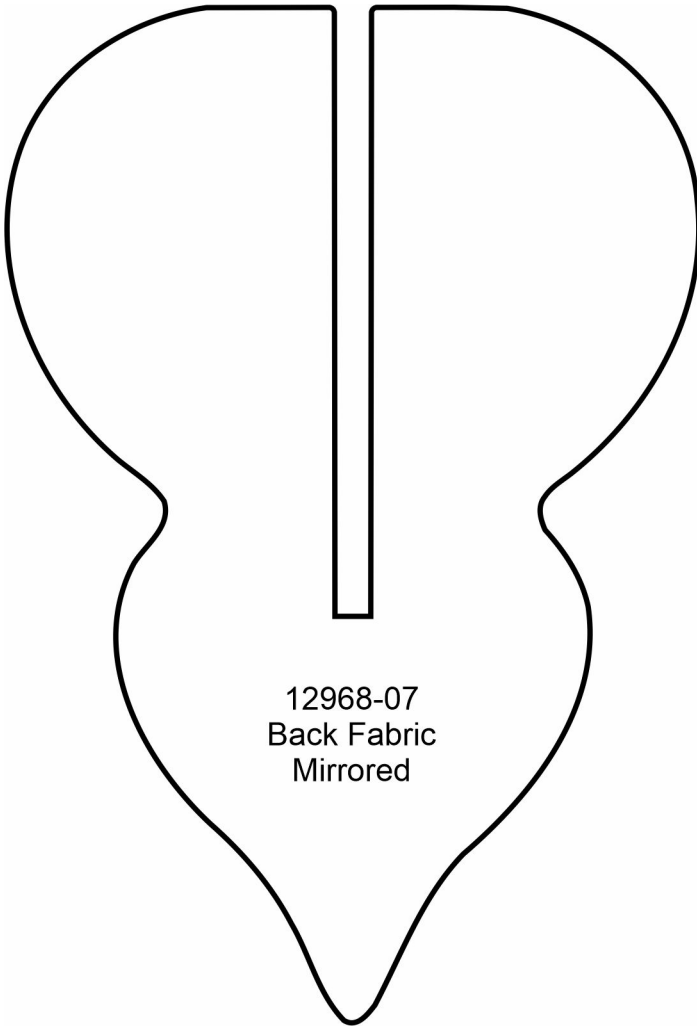

12968-07
Back Fabric
Mirrored

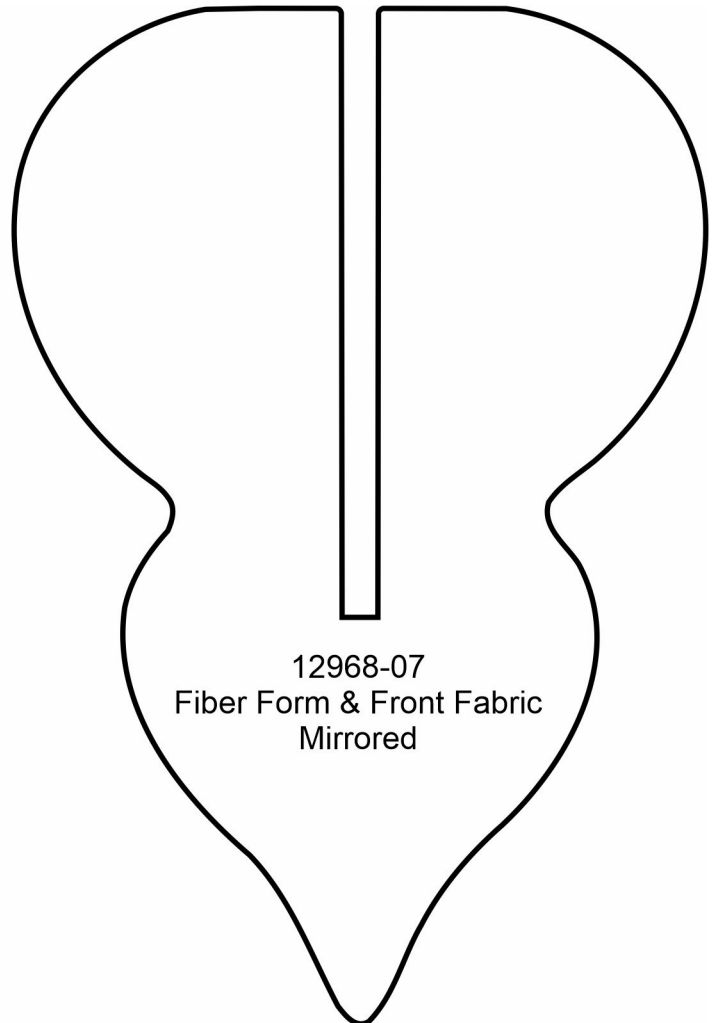

12968-07
Fiber Form & Front Fabric
Mirrored

Print at 100%. No scaling. This box measures 1" x 1". Use the box as an accuracy guide when printing templates.

MIRRORED PATTERNS PREMIER COLLECTION

Print at 100%. No scaling. This box measures 1" x 1". Use the box as an accuracy guide when printing templates.

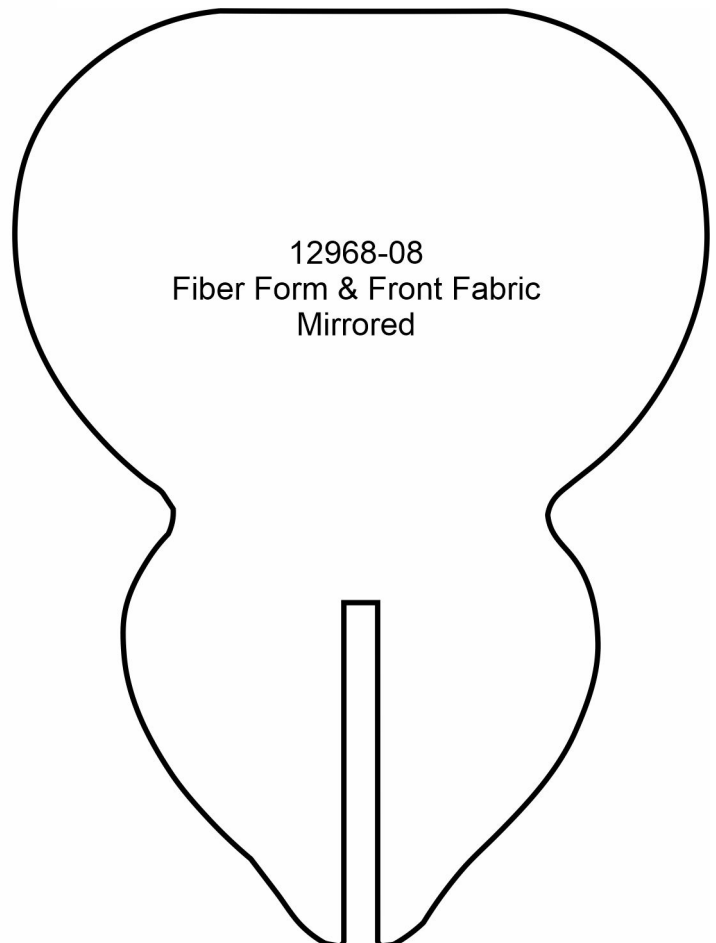
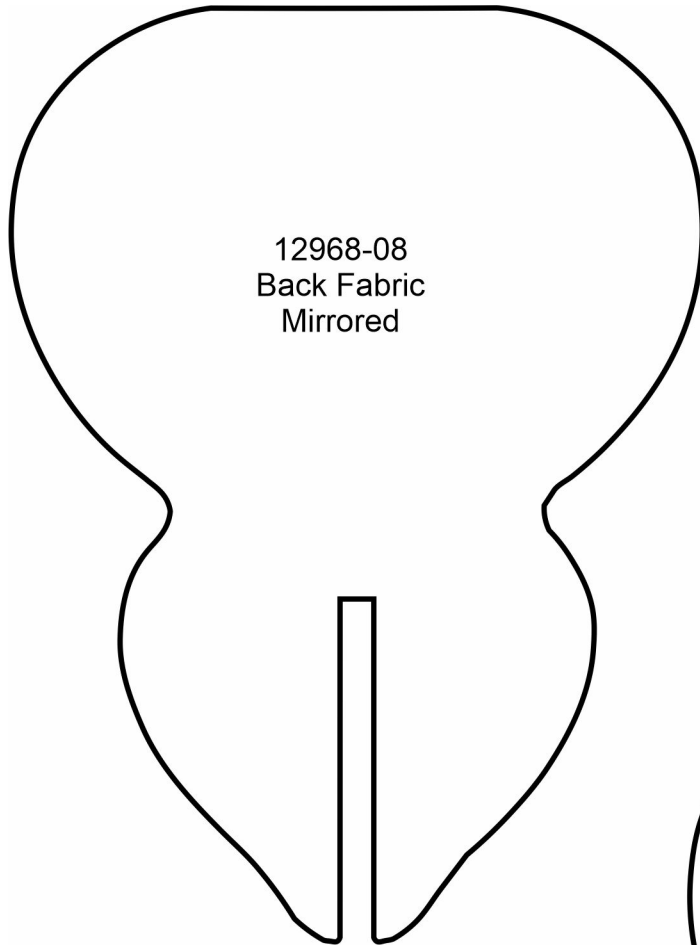

MIRRORED PATTERNS



Print at 100%. No scaling. This box measures 1" x 1". Use the box as an accuracy guide when printing templates.

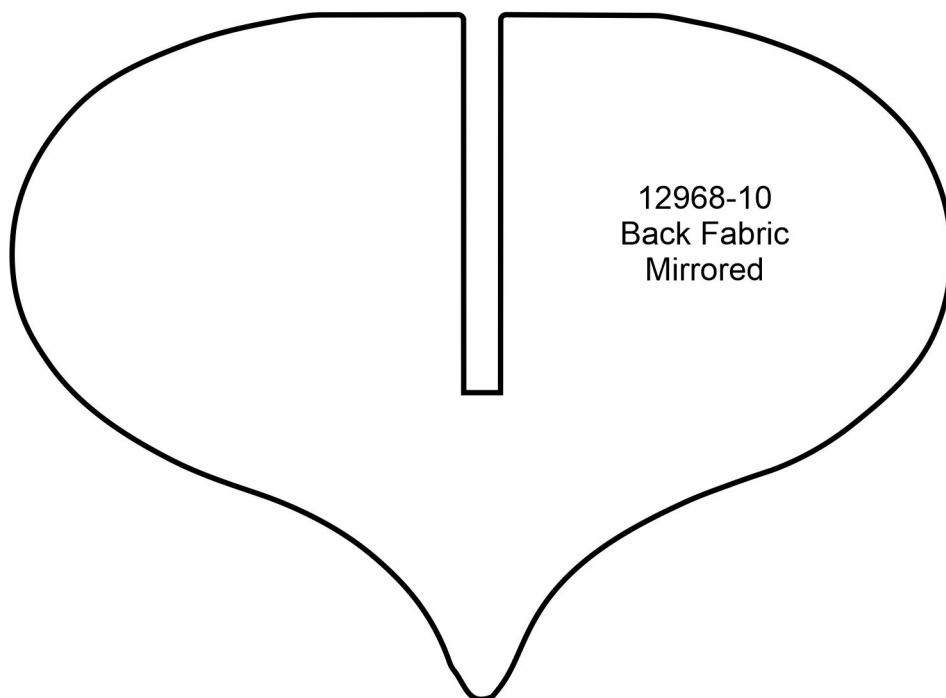
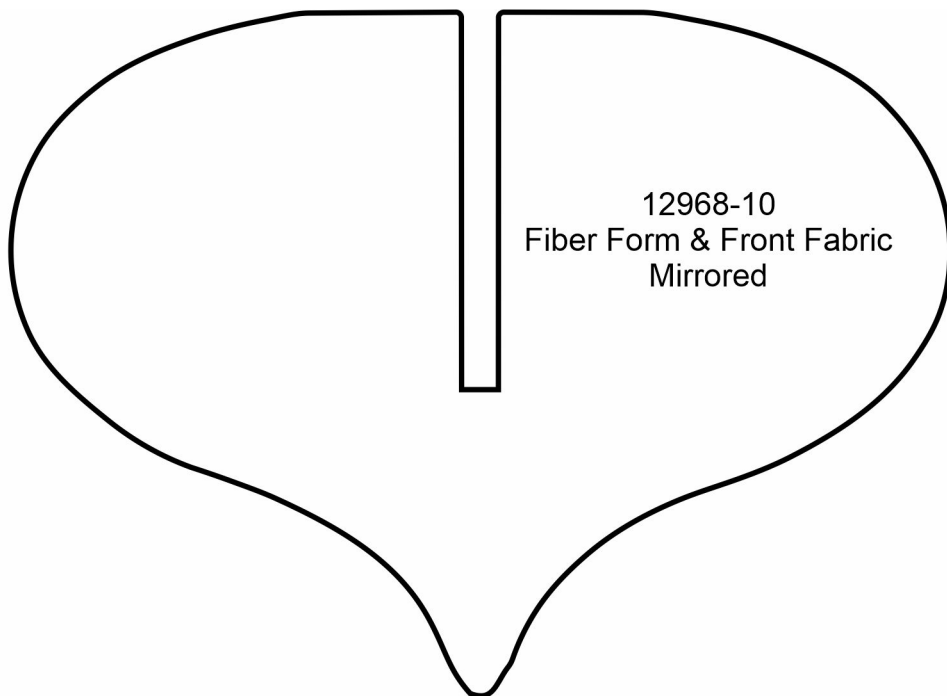

MIRRORED PATTERNS PREMIER COLLECTION

Print at 100%. No scaling. This box measures 1" x 1". Use the box as an accuracy guide when printing templates.

12968-11
Fiber Form & Front Fabric
Mirrored

A large, rounded, teardrop-shaped pattern with a small rectangular notch at the bottom center. The pattern is intended for the front fabric of a fiber form.

12968-11
Back Fabric
Mirrored

A large, rounded, teardrop-shaped pattern, identical to the one above, with a small rectangular notch at the bottom center. This pattern is intended for the back fabric of a fiber form.

MIRRORED PATTERNS **oesd**™ PREMIER COLLECTION

Print at 100%. No scaling. This box measures 1" x 1". Use the box as an accuracy guide when printing templates.

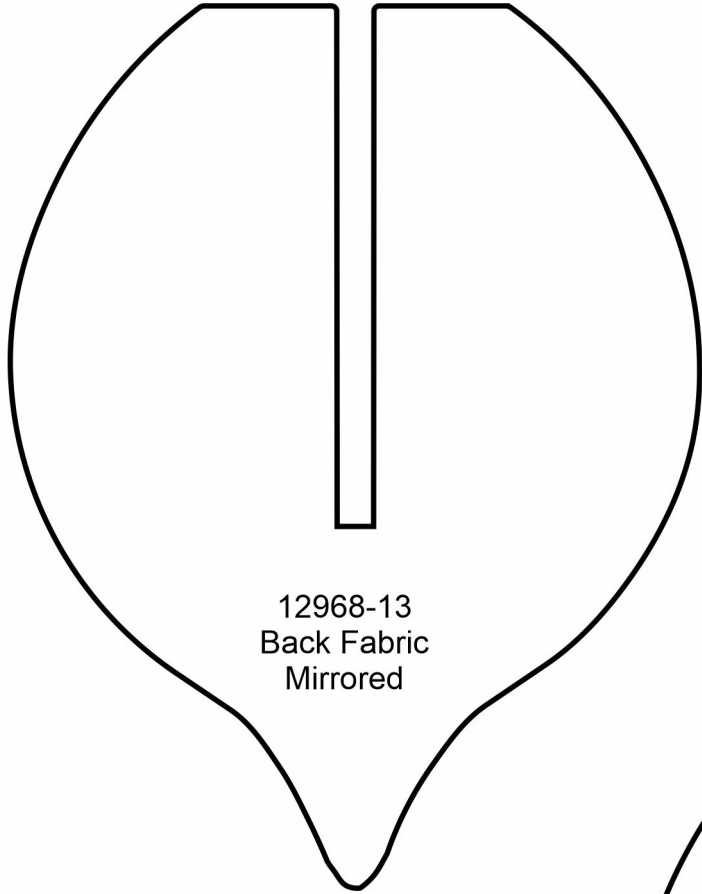

12968-13
Back Fabric
Mirrored

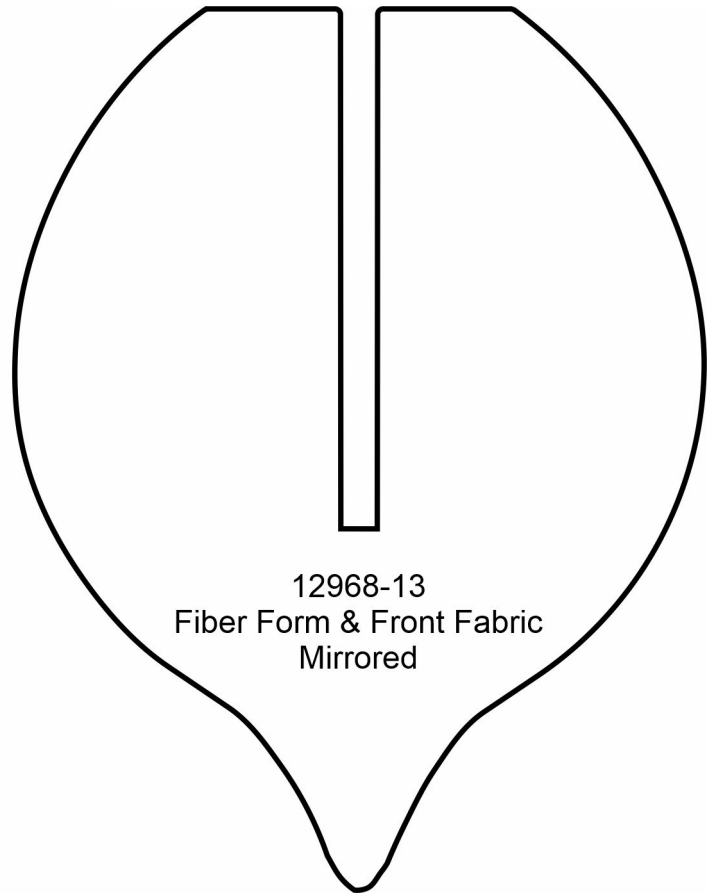

12968-13
Fiber Form & Front Fabric
Mirrored

MIRRORED PATTERNS PREMIER COLLECTION

Print at 100%. No scaling. This box measures 1" x 1". Use the box as an accuracy guide when printing templates.

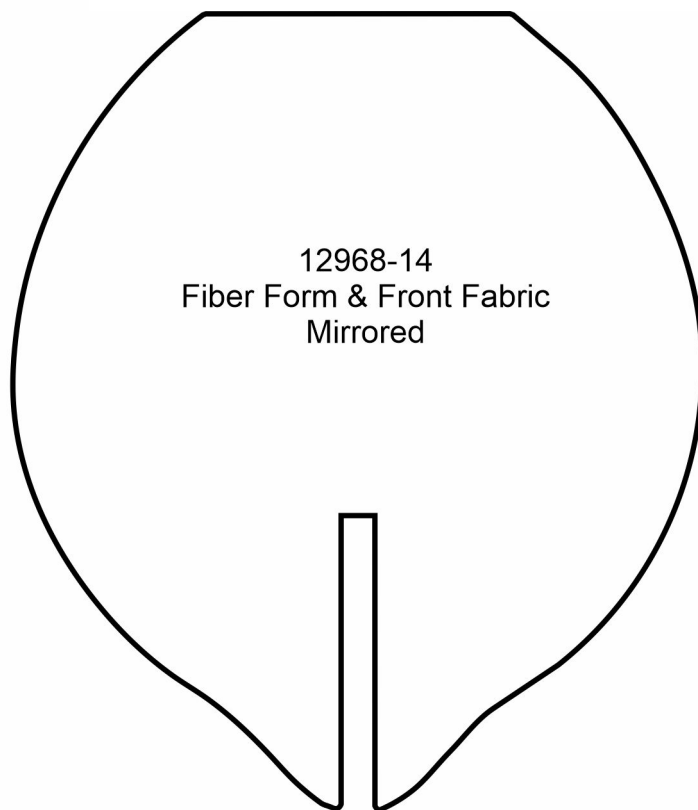
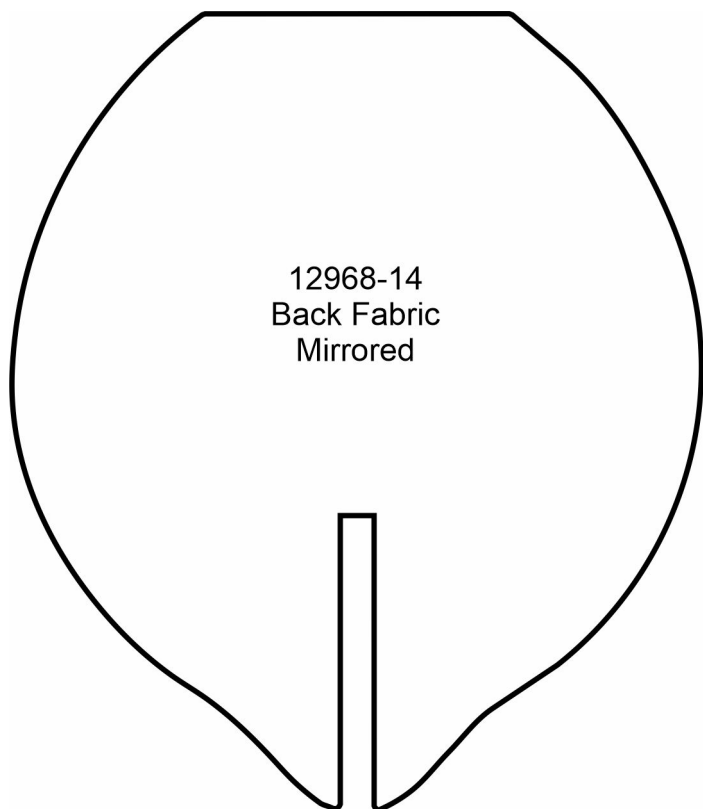

MIRRORED PATTERNS

Print at 100%. No scaling. This box measures 1" x 1". Use the box as an accuracy guide when printing templates.

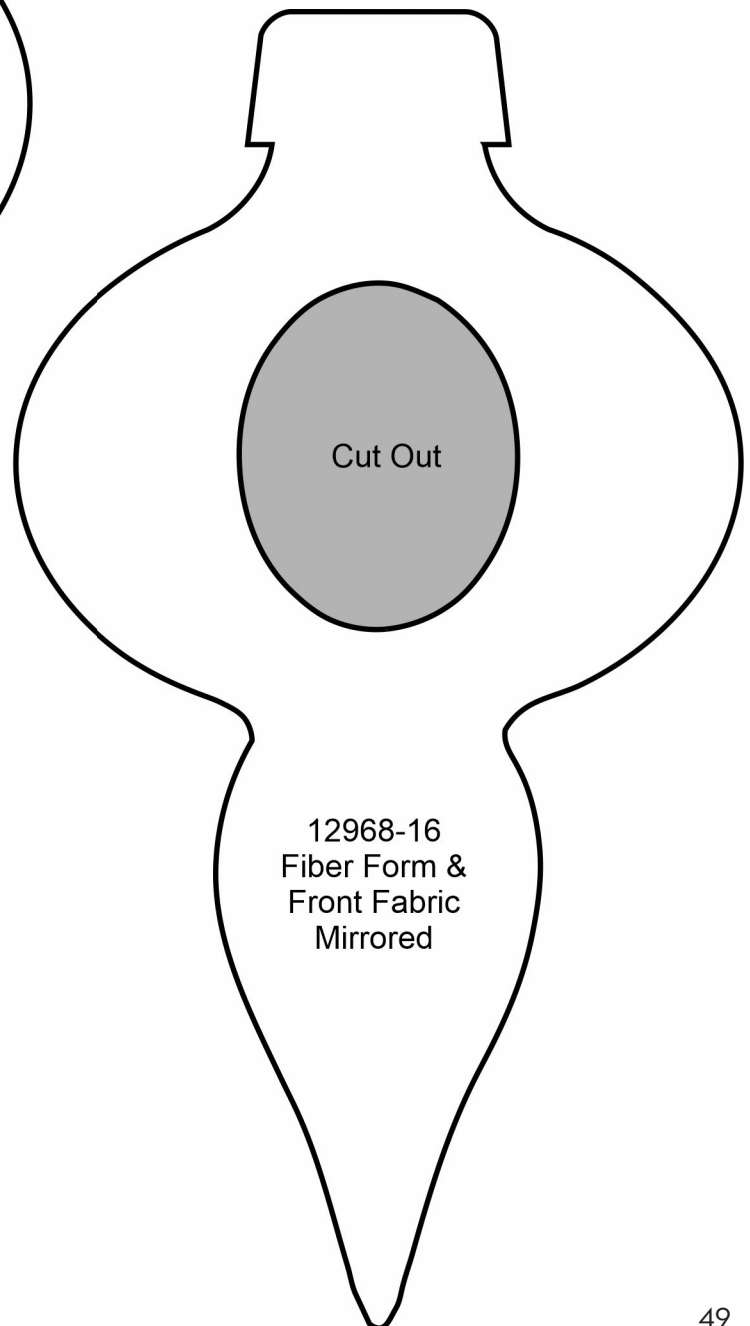
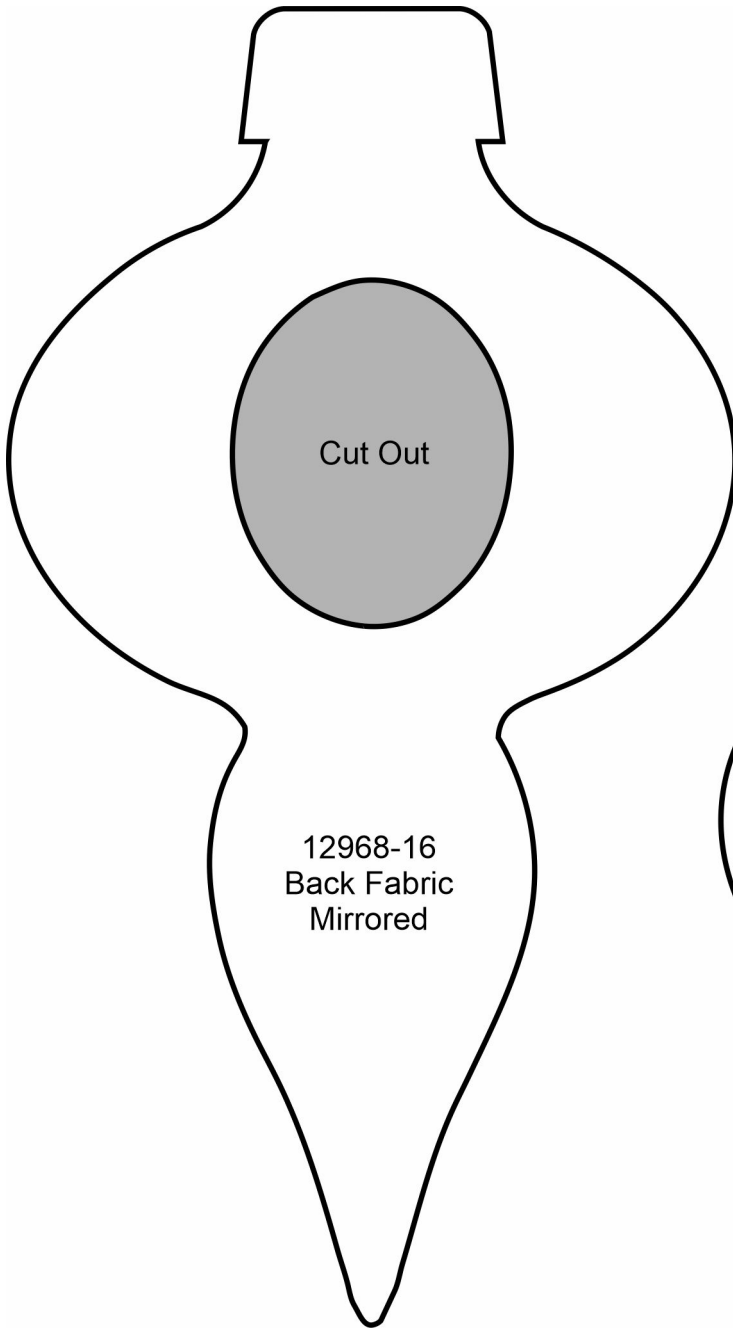

MIRRORED PATTERNS

Print at 100%. No scaling. This box measures 1" x 1". Use the box as an accuracy guide when printing templates.

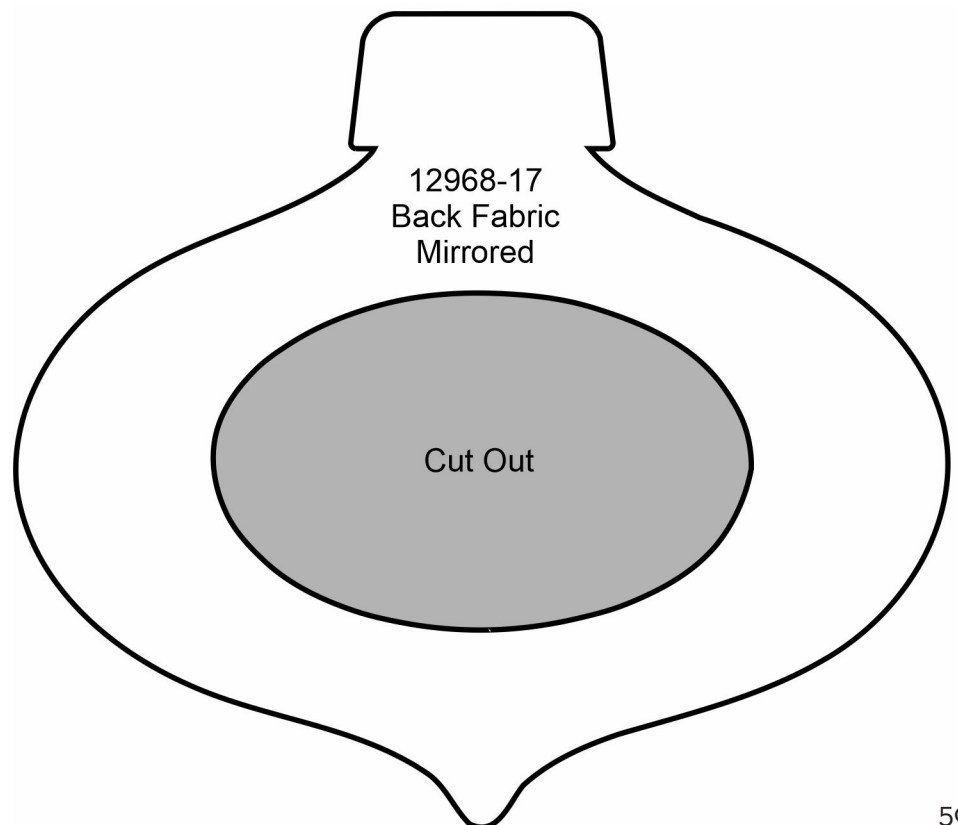
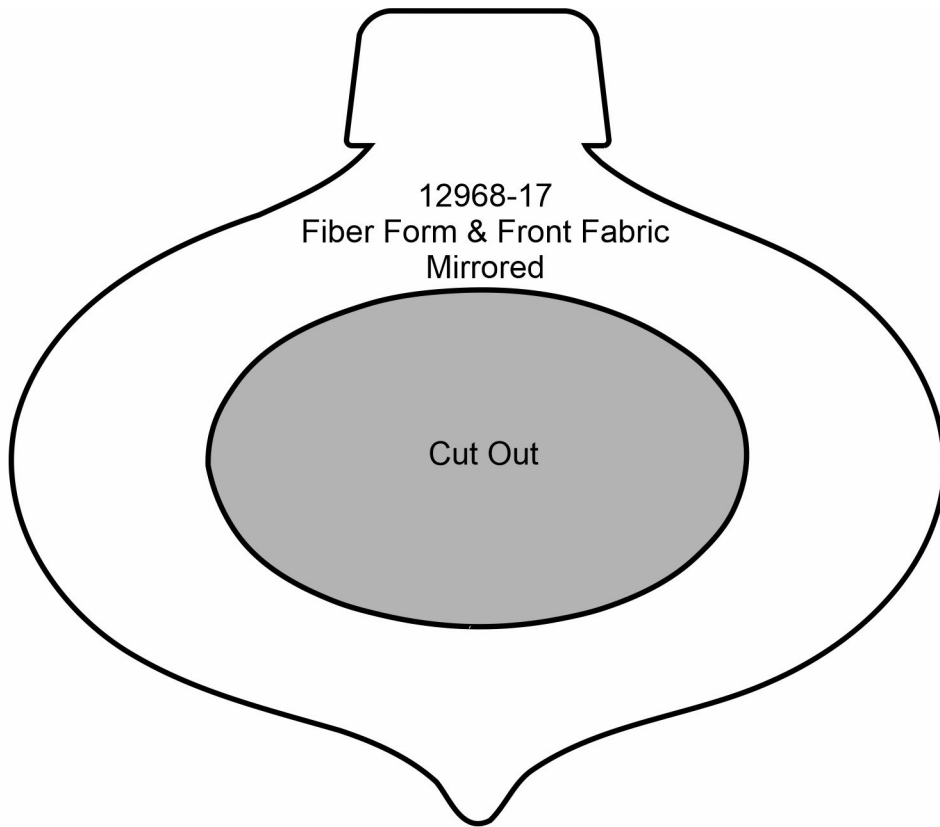

MIRRORED PATTERNS

Print at 100%. No scaling. This box measures 1" x 1". Use the box as an accuracy guide when printing templates.

12968-18
Back Fabric
Mirrored

Cut Out

12968-18
Fiber Form & Front Fabric
Mirrored

Cut Out

MIRRORED PATTERNS **oesd**™ PREMIER COLLECTION

Print at 100%. No scaling. This box measures 1" x 1". Use the box as an accuracy guide when printing templates.

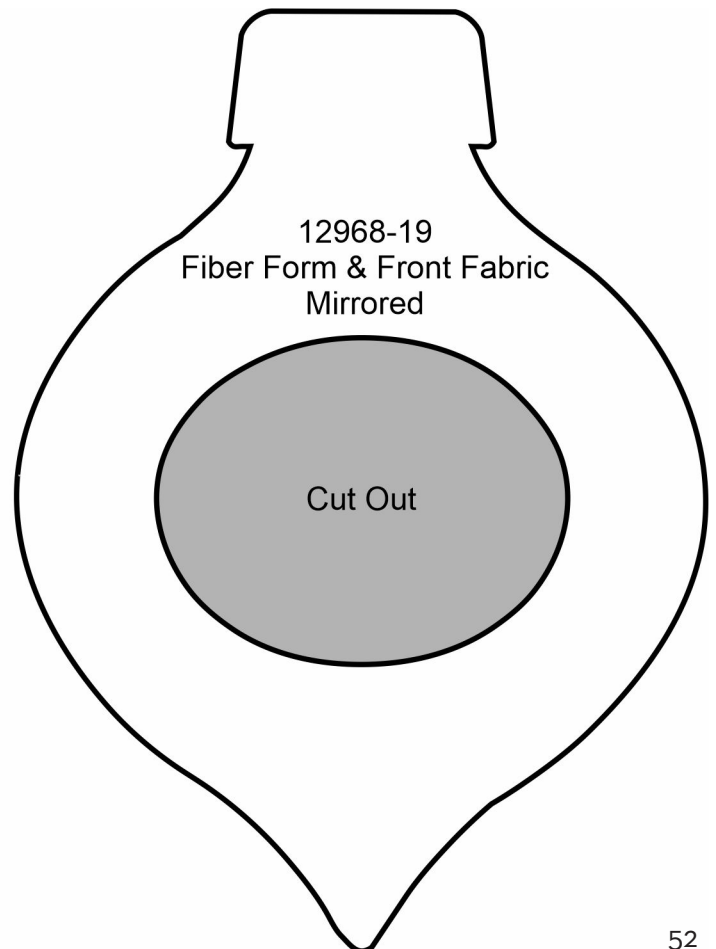
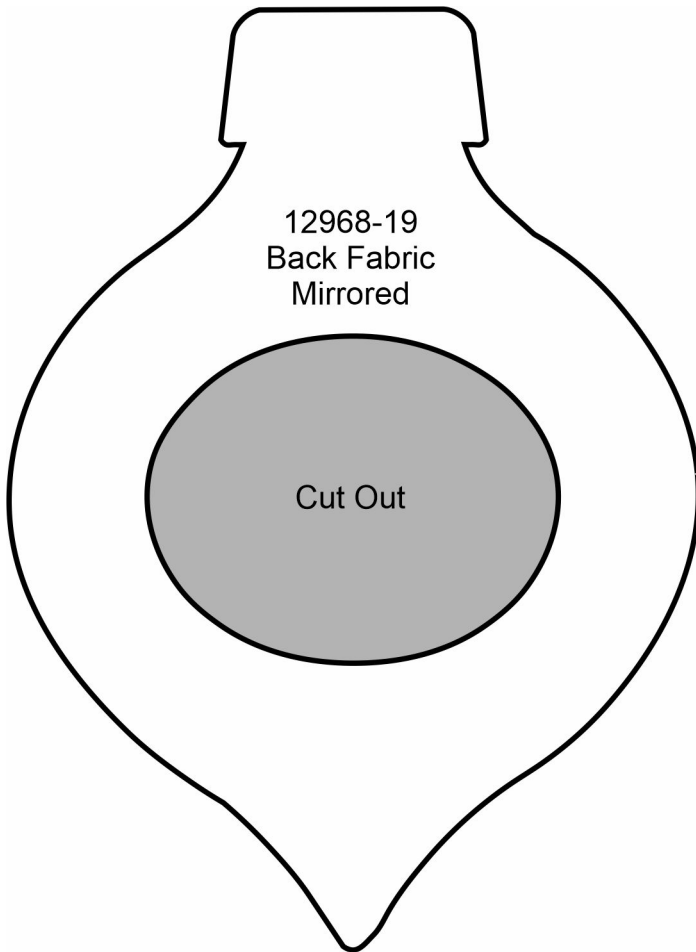

MIRRORED PATTERNS

Print at 100%. No scaling. This box measures 1" x 1". Use the box as an accuracy guide when printing templates.

