

# Freestanding Menorah



Collection No. 12988  
1 Design/10 Files

# MATERIALS



## Isacord Thread Colors

- 0741 Wheat
- 3730 Something Blue
- 3743 Harbor

**Note: One spool of 1000 meter thread is adequate for the project unless otherwise noted.**



# MATERIALS



## Stabilizers

- OESD AquaMesh WashAway
- OESD BadgeMaster WashAway
- OESD StabilStick CutAway
- OESD Fiber Form
- OESD Applique Fuse and Fix

## Fabrics/Textiles

- Light Blue Quilter's Cotton 1/4 yard
  - Blue Quilter's Cotton 1/4 yard
  - Gold Quilter's Cotton 1/4 yard
- Note: Fabric amounts are estimates and may result in overages.

## Notion & Tools

- OESD Grippy Grid
- OESD Perfect Scoring Tool
- OESD Expert Embroidery Tape TearAway
- OESD Expert Embroidery Tape WashAway
- OESD Perfect Embroidery Press Cloth
- OESD Perfect Punch Tool
- OESD MiniMat
- OESD Alligator Clamps
- OESD Button Clips
- 2 Brads

## Isacord Thread Colors

- Per the thread chart





# SUMMARY



Completed Size: 8 1/2" L x 2 1/2" W x 10 1/2" H

12988-01

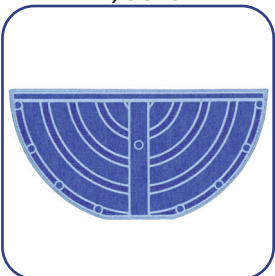

Requires 2 Designs

12988-02

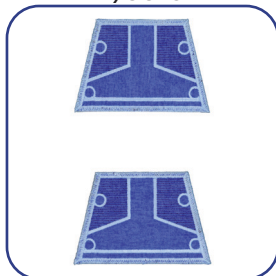

Requires 1 Design

12988-03

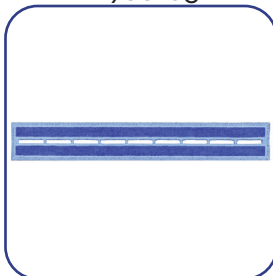

Requires 1 Design

12988-04

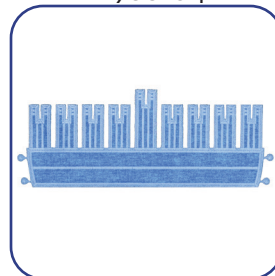

Requires 1 Design

12988-05

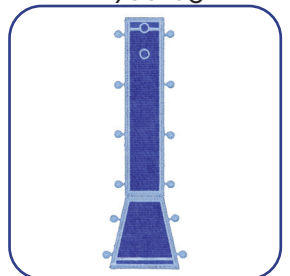

Requires 2 Designs

12988-06

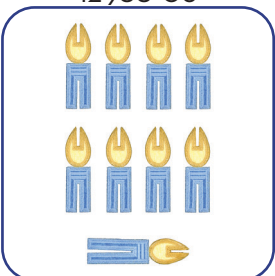

Requires 1 Design

12988-07

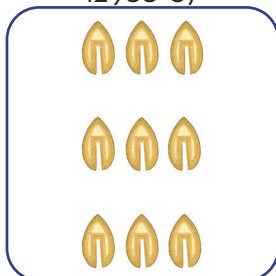

Requires 1 Design

12988-08

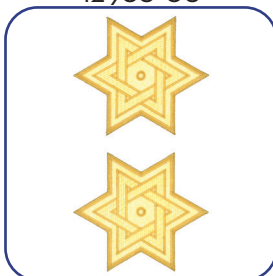

Requires 1 Design

12988-09

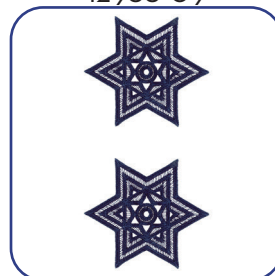

Requires 1 Design

12988-10

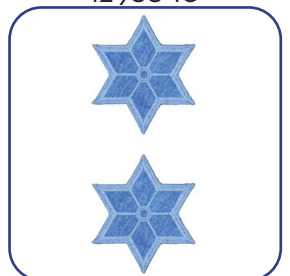

Requires 1 Design





## General Instructions

The freestanding applique instructions, included in the collection, are general instructions. For demonstration purposes, a sample design that best demonstrates the technique is shown. Fabric and thread requirements will vary by design, but the general technique is the same. All designs are stitched with matching thread in the top and the bobbin. NOTE: Some thread colors in the instructions have been changed or digitally enhanced for better visibility

## Designs

Menorah Branches FSA	12988-01
Menorah Stand FSA	12988-02
Menorah Top FSA	12988-03
Menorah Side FSA	12988-05
Menorah Star of David 1 FSA	12988-08
Menorah Star of David 3 FSA	12988-10

## Step 1

- Print the mirrored version of the templates (at 100% scale or 1:1 ratio) onto the paper side of Applique Fuse and Fix.
- Cut approximately 1/4" - 1/2" outside the printed applique templates.



## □ Step 2

- Cut the Fiber Form 1/4" - 1/2" larger than the applique templates.
- Fuse the trimmed templates to the back of the Fiber Form with the paper side of the printed templates up. Hold the iron on the template for 10-15 seconds for a secure fuse.

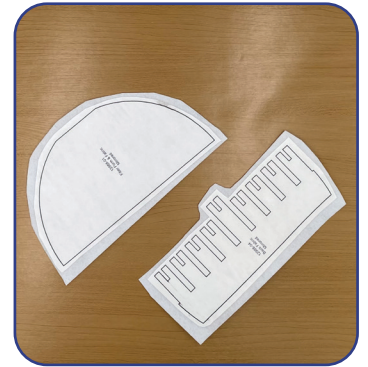

## □ Step 3

- Trim the Fiber Form on the outer edges of the black outline.
- Set aside.

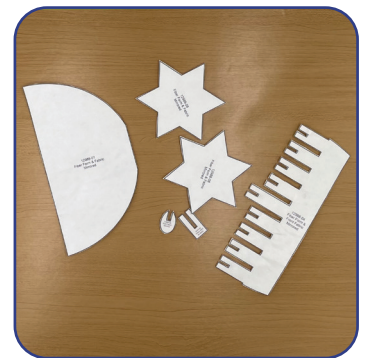

## □ Step 4

- Cut the prepared applique fabrics 1/4" - 1/2" larger than the templates that are included at the end of the instructions.
- Adhere one layer of StabilStick CutAway to the wrong side of all applique fabrics to provide stiffness to the finished structure.



## □ Step 5

- Hoop one layer of Aquamesh and one layer of BadgeMaster for all designs.

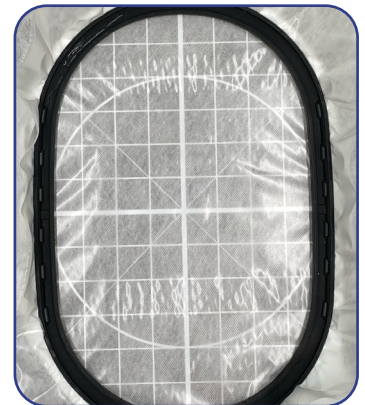



## □ Step 6

- Load the selected design into the machine.
- Example design in 12988-01.
- Thread the machine per the thread chart.
- Place the hoop on the machine.
- Stitch Machine Step 1, Fiber Form/Blue Fabric Placement Stitch.



## □ Step 7

- Remove the hoop from the machine, but NOT the project from the hoop.
  - Place the hoop on a flat surface.
  - On the back of the Fiber Form, use the OESD Perfect Scoring Tool to score and remove the paper backing to reveal the adhesive surface.
  - Place the Fiber Form within the placement stitching.
  - Finger press to secure.
- Tip: Applique Fuse and Fix is repositionable.



## Step 8

- Completely cover the Fiber Form with the prepared blue applique fabric.
- Tape in place with OESD Expert Embroidery Tape TearAway to secure.

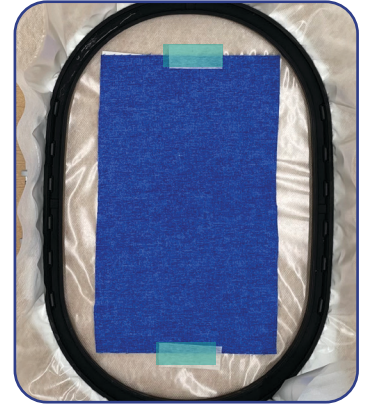

## Step 9

- Return the hoop to the machine.
- Stitch Machine Step 2, Cut Line and Tackdown.

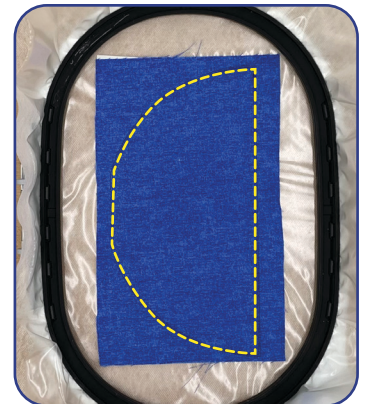

## Step 10

- Remove the hoop from the machine, but NOT the project from the hoop.
- Trim the excess fabric as close to the cut line as possible. If the outermost stitches (cut line) are cut, the inner stitches (tackdown) will hold the applique in place. Tip: If the stabilizer is cut or a hole is created while trimming the fabric, use OESD Expert Embroidery Tape WashAway as a patch.



## □ Step 11

- Return the hoop to the machine.
- Stitch the remaining machine steps per the thread chart with matching bobbin thread.



## □ Step 12

- When the design is complete, remove the project from the hoop.
- Trim the stabilizer 1/4" - 1/2" outside the design.





## Designs

Menorah Candles FSA	12988-04
Menorah Candles with Flames FSA	12988-06
Menorah Flames FSA	12988-07

### □ Step 13

- Print the mirrored version of the templates (at 100% scale or 1:1 ratio) onto the paper side of Applique Fuse and Fix.
- Cut approximately 1/4" - 1/2" outside the printed applique templates.

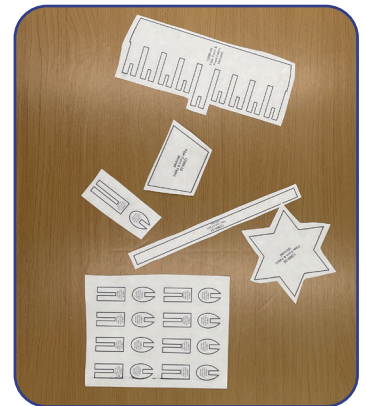

### □ Step 14

- Cut the Fiber Form 1/4" - 1/2" larger than the applique templates.
- Fuse the trimmed templates to the back of the Fiber Form with the paper side of the printed templates up. Hold the iron on the template for 10-15 seconds for a secure fuse.

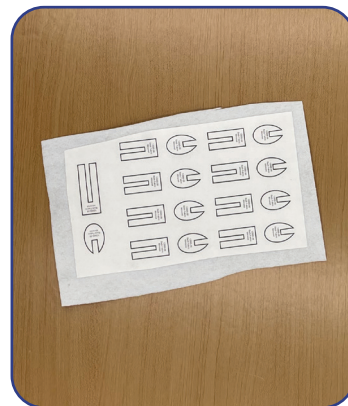

## Step 15

- Trim the Fiber Form on the outer edges of the black outline.
- Set aside.

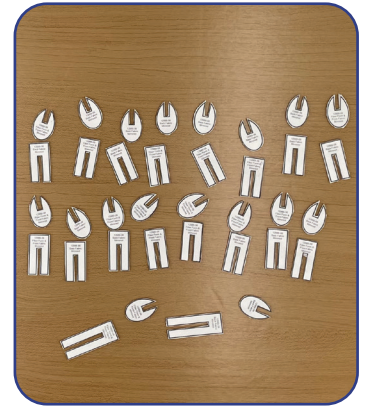

## Step 16

- Cut the prepared applique fabrics 1/4" - 1/2" larger than the templates that are included at the end of the instructions.
- Adhere one layer of StabilStick CutAway to the wrong side of all applique fabrics to provide stiffness to the finished structure.

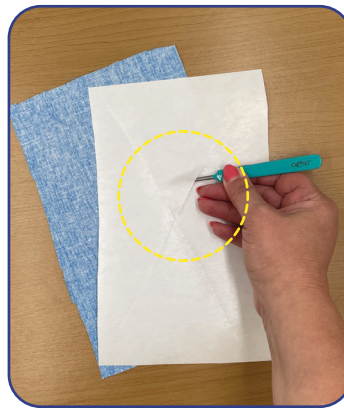

## □ Step 17

- Using the OESD Grippy Grid, hoop one layer of Aquamesh and one layer of BadgeMaster for all designs.

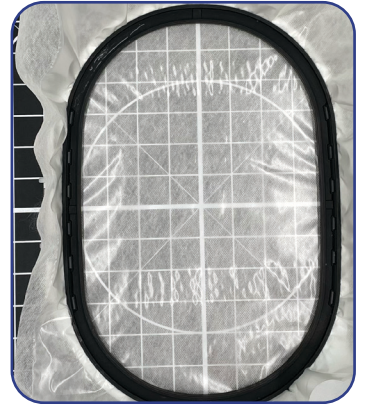

## □ Step 18

- Load the selected design into the machine.
- Example design is 12988-06.
- Thread the machine per the thread chart.
- Place the hoop on the machine.
- Stitch Machine Step 1, Fiber Form/Front and Back Gold Fabric Placement Stitch.





## Step 19

- Remove the hoop from the machine, but NOT the project from the hoop.
- Place the hoop on a flat surface.
- On the back of the Fiber Form, use the OESD Perfect Scoring Tool to score and remove the paper backing to reveal the adhesive surface.
- Place the Fiber Form within the placement stitching.
- Finger press to secure.



## Step 20

- Completely cover the Fiber Form with the prepared gold applique fabric.
- Tape in place with OESD Expert Embroidery Tape TearAway to secure.

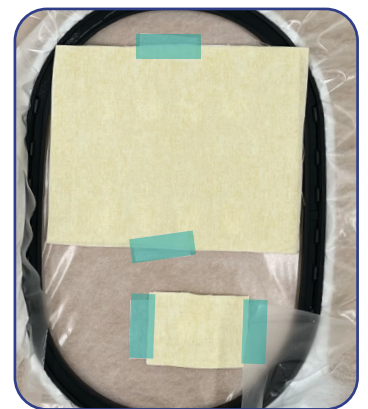

## Step 21

- Turn the hoop over and place the prepared gold applique fabric, right side up, completely covering the placement stitch.
- Carefully tape to secure.  
Tip: Avoid pushing too hard on the stabilizer to prevent it from dislodging from the hoop.



## Step 22

- Return the hoop to the machine.
- Stitch Machine Step 2, Cut Line and Tackdown.

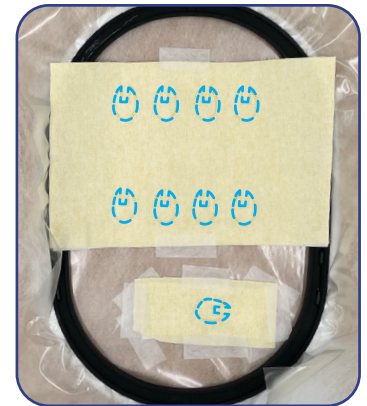

## Step 23

- Remove the hoop from the machine, but NOT the project from the hoop.
- Trim the excess fabric as close to the cut line as possible. If the outermost stitches (cut line) are cut, the inner stitches (tackdown) will hold the applique in place.
- Turn the hoop over.
- Trim the excess fabric as close to the cut line as possible.  
Tip: If the stabilizer is cut or a hole is created while trimming the fabric, use OESD Expert Embroidery Tape WashAway as a patch.



## Step 24

- Return the hoop on the machine.
- Stitch Machine Step 3, Fiber Form/Front and Back Light Blue Fabric Placement Stitch.



## Step 25

- Remove the hoop from the machine, but NOT the project from the hoop.
- Place the hoop on a flat surface.
- On the back of the Fiber Form, score and remove the paper backing to reveal the adhesive surface.
- Place the Fiber Form within the placement stitching.
- Finger press to secure.

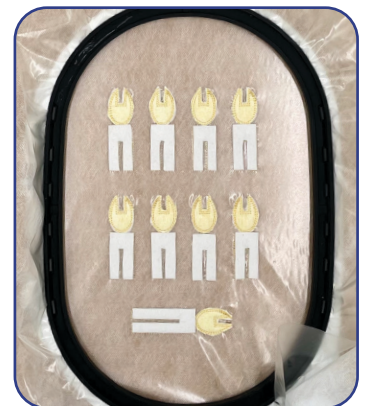

## Step 26

- Completely cover the Fiber Form with the prepared light blue applique fabric.
- Tape in place.

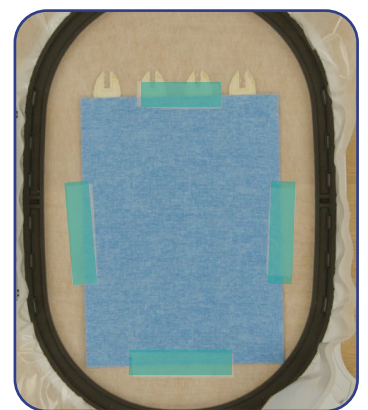



## Step 27

- Turn the hoop over and place the prepared light blue applique fabric, right side up, completely covering the placement stitch.
- Carefully tape to secure.



## Step 28

- Return the hoop to the machine.
- Stitch Machine Step 4, Cut Line and Tackdown.

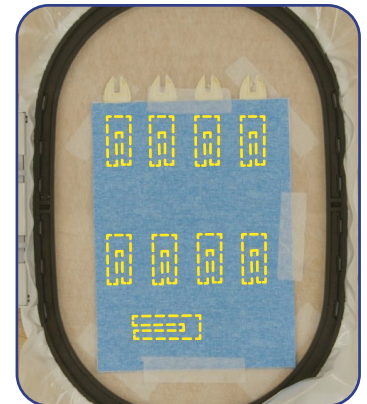

## Step 29

- Remove the hoop from the machine, but NOT the project from the hoop.
- Trim the excess fabric as close to the cut line as possible.
- Turn the hoop over.
- Trim the excess fabric as close to the cut line as possible.



## Step 30

- Return the hoop to the machine.
- Stitch the remaining machine steps per the thread chart with matching bobbin thread.



## Step 31

- When the design is complete, remove the project from the hoop.
- Trim the stabilizer 1/4" - 1/2" outside the design.



# GENERAL FREESTANDING LACE GUIDE



## Designs

Design Name	Design Number	Requires
Menorah Star of David 2 FSL	12988-09	1

## Stabilizer

- OESD AquaMesh
- OESD BadgeMaster

## Notion/Tools

- 80/12 Embroidery Ballpoint Titanium needle for extended needle life
- OESD Alligator Clamps
- OESD Button Clips
- OESD Perfect Point and Press Tool

## Instructions

### Step 1 - Hoop

For FSL structures, hoop one layer of OESD AquaMesh and one layer of OESD BadgeMaster. BadgeMaster contains more starch so, combined with the AquaMesh, the lace is more rigid.

For other FSL, where a softer lace is desired, hoop two layers of AquaMesh.

### Step 2 - Embroider

Stitch the design per the thread chart with matching thread in the bobbin at each color change.

When complete, remove from the hoop and trim away excess stabilizer about 1/4"-1/2" from the stitching.

### Step 3 - Rinse

Rinse remaining stabilizer out in warm running water.

For stiffer lace and FSL structures, DO NOT rinse away all of the stabilizer. The lace should be just slightly tacky.

For softer lace, rinse until all traces of the stabilizer is removed.

### Step 4 - Dry

Lay right side down flat on a non-stick surface, such as a cookie rack, parchment paper or Teflon sheet. This minimizes the tendency for the lace to curl.

Let the pieces dry completely before proceeding with any assembly.

## Isacord Thread Colors

- All OESD designs are digitized with Isacord 40 wt. polyester thread as the top thread and in the bobbin.
- Refer to the thread chart for color specifications.
- Match bobbin thread color to the top thread.

### Step 5 - Press

Once completely dry, press right side down on a OESD Perfect Embroidery Press Cloth.

### Step 6 - Assemble Structure

Note: Specific assembly instructions for a design/collection may be found in the thread chart pdf following the individual design color charts.

Lace must be COMPLETELY DRY before assembly. Wetting the buttonettes or eyelets to assemble is not recommended and may result in them stretching and coming "unbuttoned" when dry.

Use a pair of OESD Alligator Clamps to insert the buttonettes into the eyelets. Insert the tip of the OESD Alligator Clamps into the eyelet, grasp the buttonette and pull through the eyelet. Alternatively, use a stiletto or tweezers to push the buttonette through the eyelet.

## Helpful Tips

### Limp Lace

If the design is not stiff enough, press the lace pieces on the wrong side while applying spray starch. After ironing, spray again with starch and allow to dry completely. This will stiffen the lace pieces nicely and aid in construction. Or easily re-stiffen by diluting some stabilizer scraps in water (or use liquid starch) and dipping the item in the solution. Lay flat to dry.

### Eyelets Too Small

If any of the eyelets appear closed or too small to penetrate with Alligator Clamps, they may be stretched by inserting the small end of the OESD Perfect Point and Press Tool into the eyelet opening and stretching it open wide enough to accommodate the OESD Alligator Clamps.

### Button Clips

During the assembly process, some structures pull on buttonettes that have already been inserted and could pull them out altogether. Putting a Button Clip on the assembled buttonette will keep it in position during the assembly process. Remove the Button Clips when the assembly is complete.

### Alternative Construction Option

In some cases, the buttonettes may be pulled to the inside of a project, instead of being visible on the outside.

Insert the OESD Alligator Clamps through the eyelet from the wrong, or inside, of the lace and grasp the corresponding buttonette. Pull the buttonette to the wrong side of the lace.

Pulling the buttonettes to the inside may cause stress on the ones already done. Button clips may be placed on the completed buttonette(s) to prevent them from pulling out of the eyelet.

# ASSEMBLY

## □ Step 32

- Rinse each piece in warm running water until the design is only slightly tacky.
- Place right side down on a non-stick surface to dry. Parchment paper or a cooling rack work well. Dry completely.
- Once dry, press right side down on an OESD Perfect Embroidery Press Cloth.



## □ Step 33

- Before assembly, use the OESD MiniMAT and the OESD Perfect Punch Tool with the 2mm and 3mm attachments to create the eyelets indicated in the diagram.
- Reference the Punch Tool Guide on page 25.  
Tip: Take care to not cut the satin stitching.

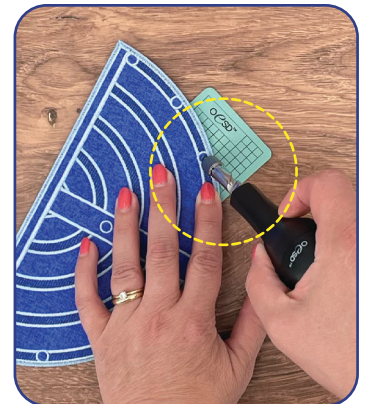

## □ Step 34

- Using a multi-step zigzag stitch, attach the Menorah Top (12988-03) to the Menorah Sides (12988-05).

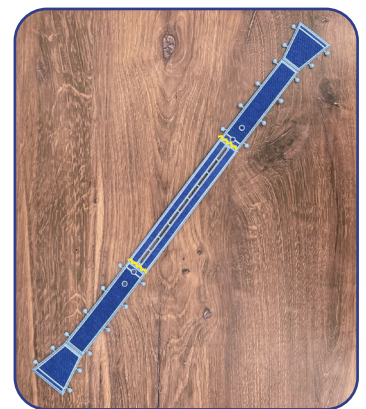



# ASSEMBLY

## □ Step 35

- Using a multi-step zigzag stitch, attach the Menorah Branches (12988-01) to the Menorah stands (12988-02).

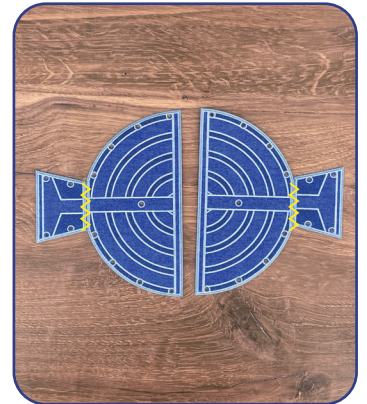

## □ Step 36

- Using a multi-step zigzag stitch, attach the Menorah Branches (12988-01) to the Menorah top (12988-03).

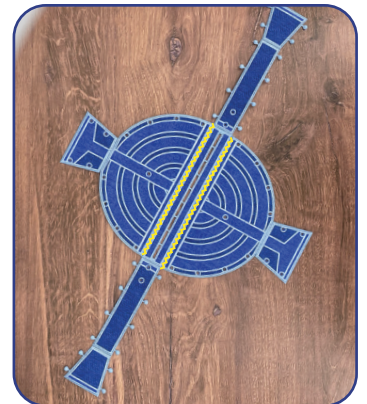

# ASSEMBLY

## □ Step 37

- Insert Menorah Candles (12988-04) into the Menorah Top (12988-03) so that they are all the way through.



## □ Step 38

- Match the buttonettes from the Menorah Sides (12988-05) to the buttonettes on the Menorah Branches (12988-01). Using OESD Alligator Clamps, pull the buttonettes through the eyelets. Use button clips to temporarily hold them in place.  
Note: It is easier to attach the Menorah Stands (12988-02) to the Menorah Sides (12988-05) after you have placed the desired Menorah Stars (12988-08, 12988-09 & 12988-10).

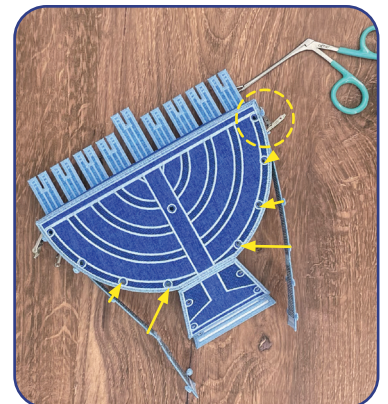

# ASSEMBLY

## □ Step 39

- Insert a brad into the eyelet of the desired Menorah Star(s) (12988-08, 12988-09 & 12988-10). Then insert into the middle of the Menorah Branch (12988-01). Reaching up through the inside of the Menorah, bend each tab of the brad back against the Menorah to secure.

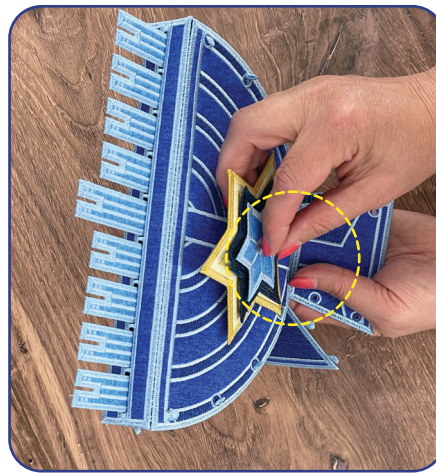

## □ Step 40

- Match the buttonettes from the Menorah Sides (12988-05) to the buttonettes on the Menorah Stands (12988-02). Using OESD Alligator Clamps, pull the buttonettes through the eyelets. Use button clips to temporarily hold them in place.

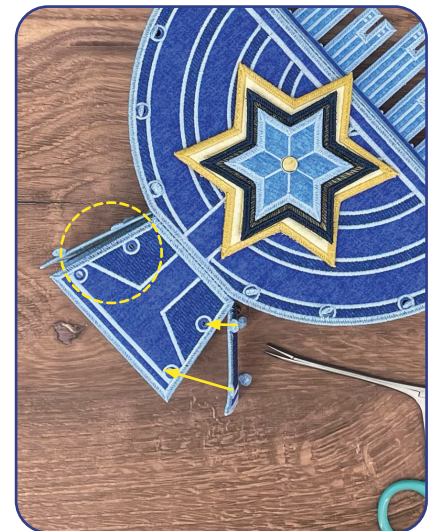



# ASSEMBLY

## □ Step 41

- To light the Menorah, slide the tallest Menorah Candles with Flames (12988-06) into the center Menorah Candles (12988-04) slot. Then slide a Menorah Flame (12988-07) into the tallest Menorah Candle with Flames (12988-06) slot.



## □ Step 42

- Continue lighting the Menorah from left to right by inserting a Menorah Candle with Flame into a Menorah Candle slot. Then slide a Menorah Flame into the Menorah Candle with Flame slot.

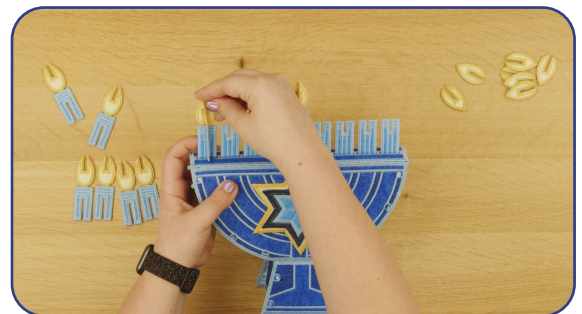

## □ Step 43

- The project is complete. Enjoy!





# PUNCH TOOL GUIDES



12988-01

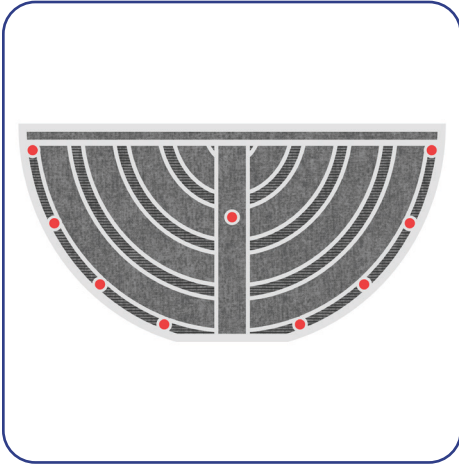

12988-02

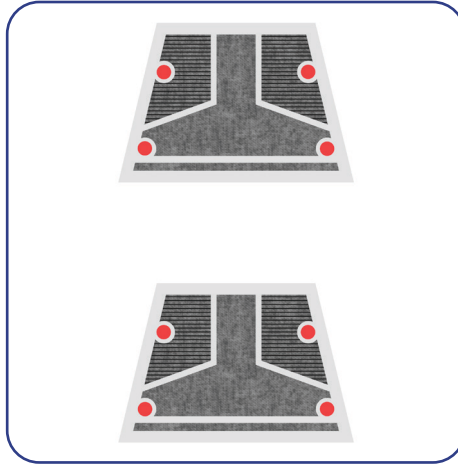

12988-05

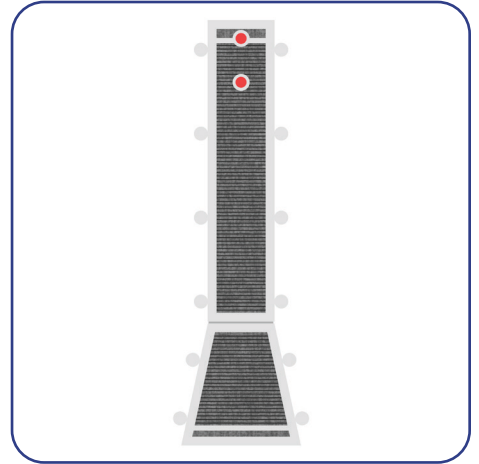

12988-08

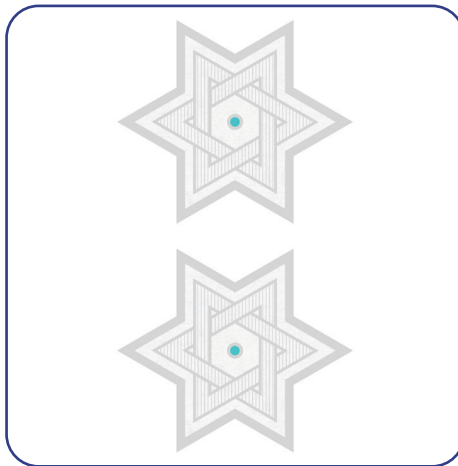

12988-10

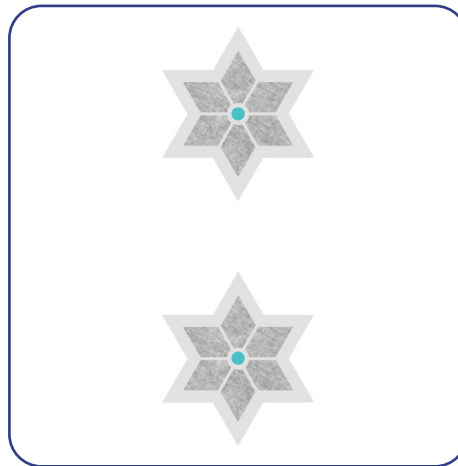

● = 2 MM

● = 3 MM

● = 4 MM

CRAFT KNIFE



## ATTENTION

When printing this document, any page scaling or page fitting options in your print dialog box must be turned OFF or set to NONE so that your files will print out at their actual size. Images not printed at actual size will not function as intended.

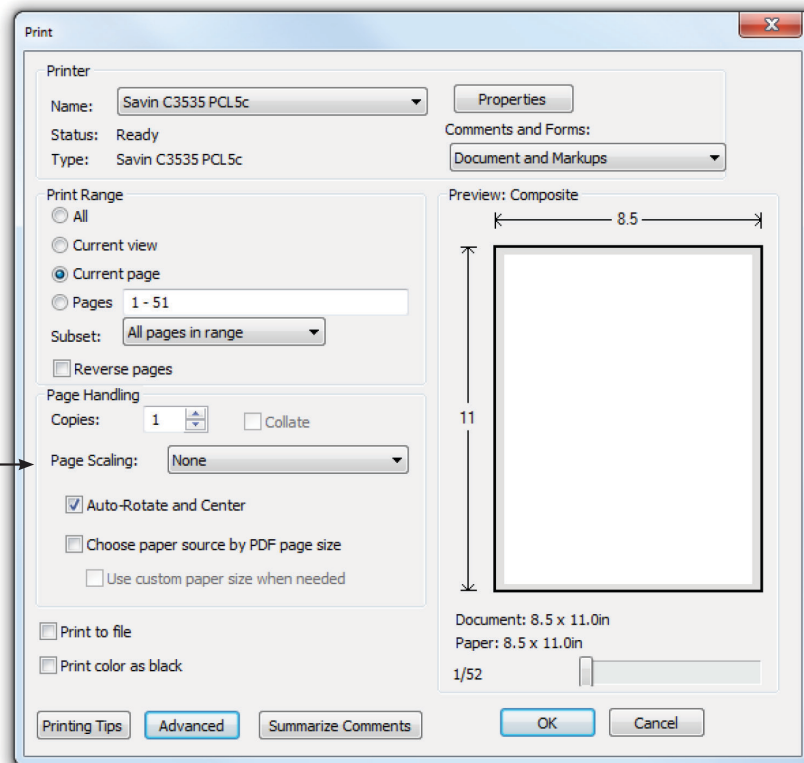

## TO SAVE PAPER

Only print the desired image by navigating to the image's page, go to File > Print and select "Current page" in the print dialog box. Repeat for each desired image.

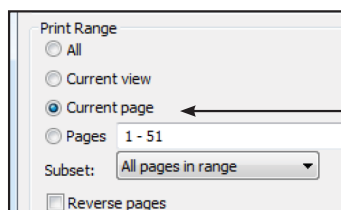

# APPLIQUE PATTERNS

**OESD**™ PREMIER  
COLLECTION

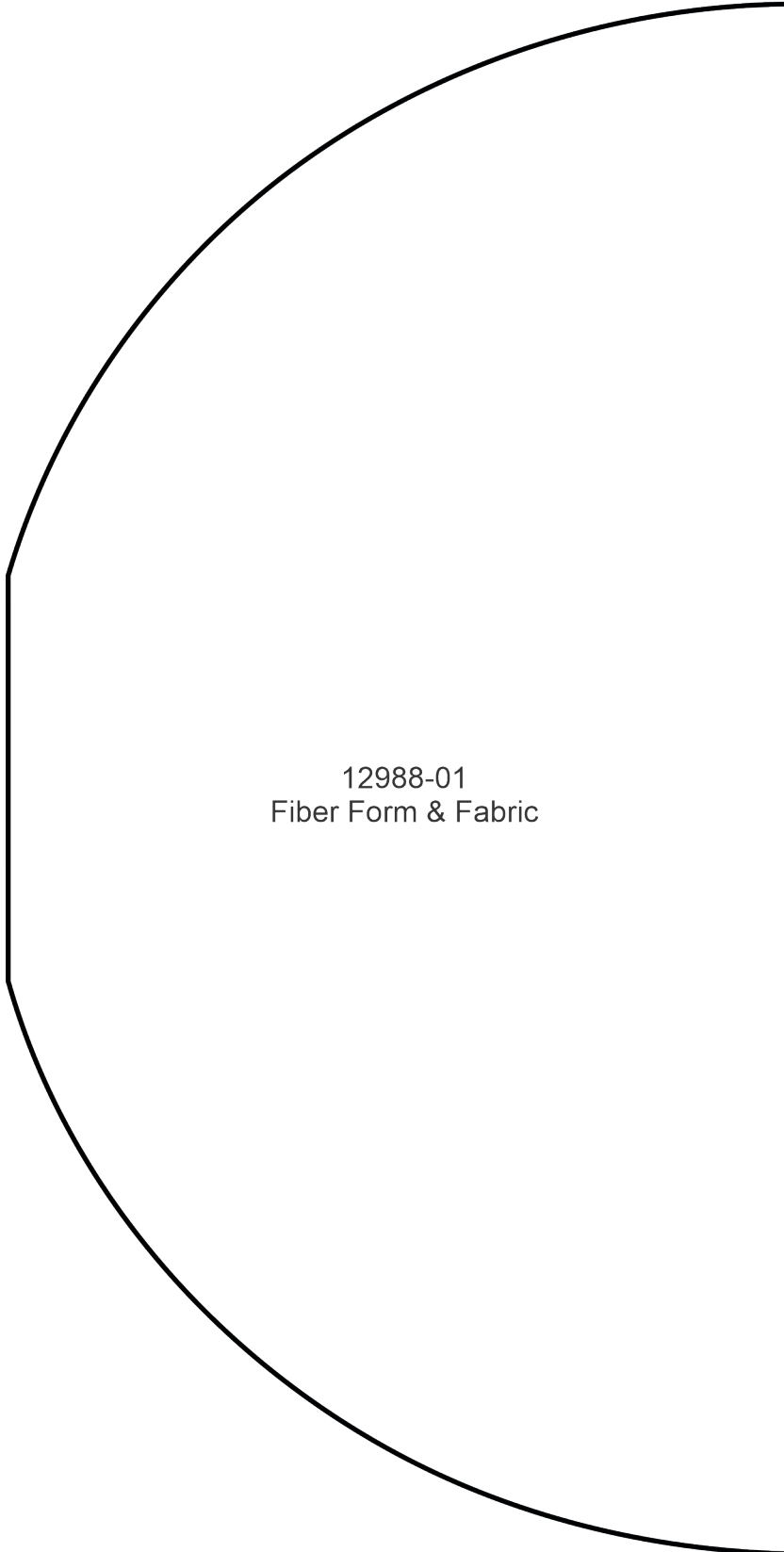

12988-01  
Fiber Form & Fabric

Print at 100%. No  
scaling. This box  
measures 1" x 1".  
Use the box as an  
accuracy guide  
when printing  
templates.

# APPLIQUE PATTERNS

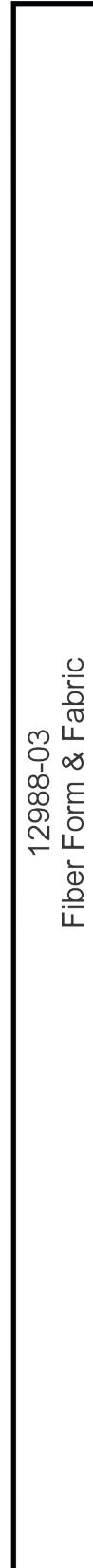
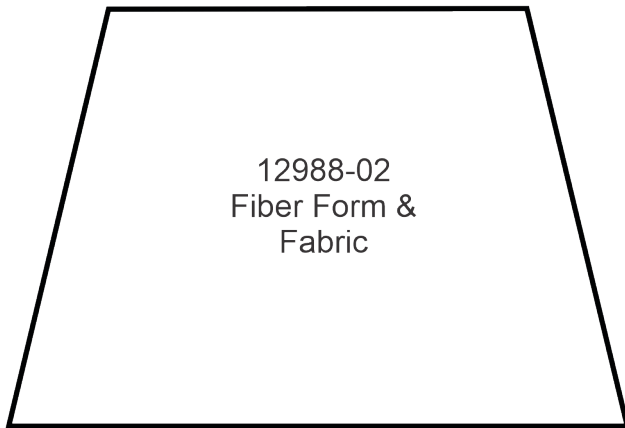
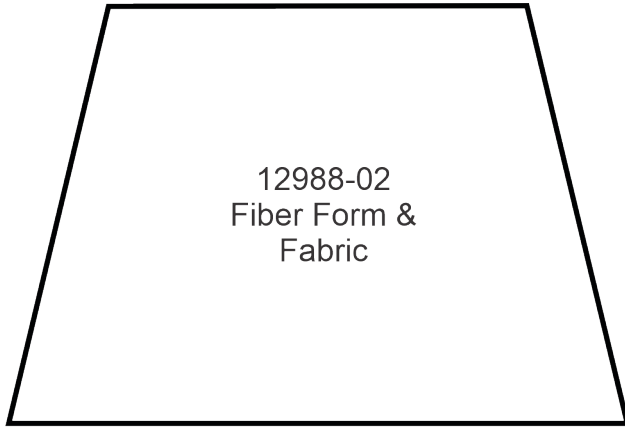

Print at 100%. No scaling. This box measures 1" x 1". Use the box as an accuracy guide when printing templates.



# APPLIQUE PATTERNS

Print at 100%. No scaling. This box measures 1" x 1". Use the box as an accuracy guide when printing templates.

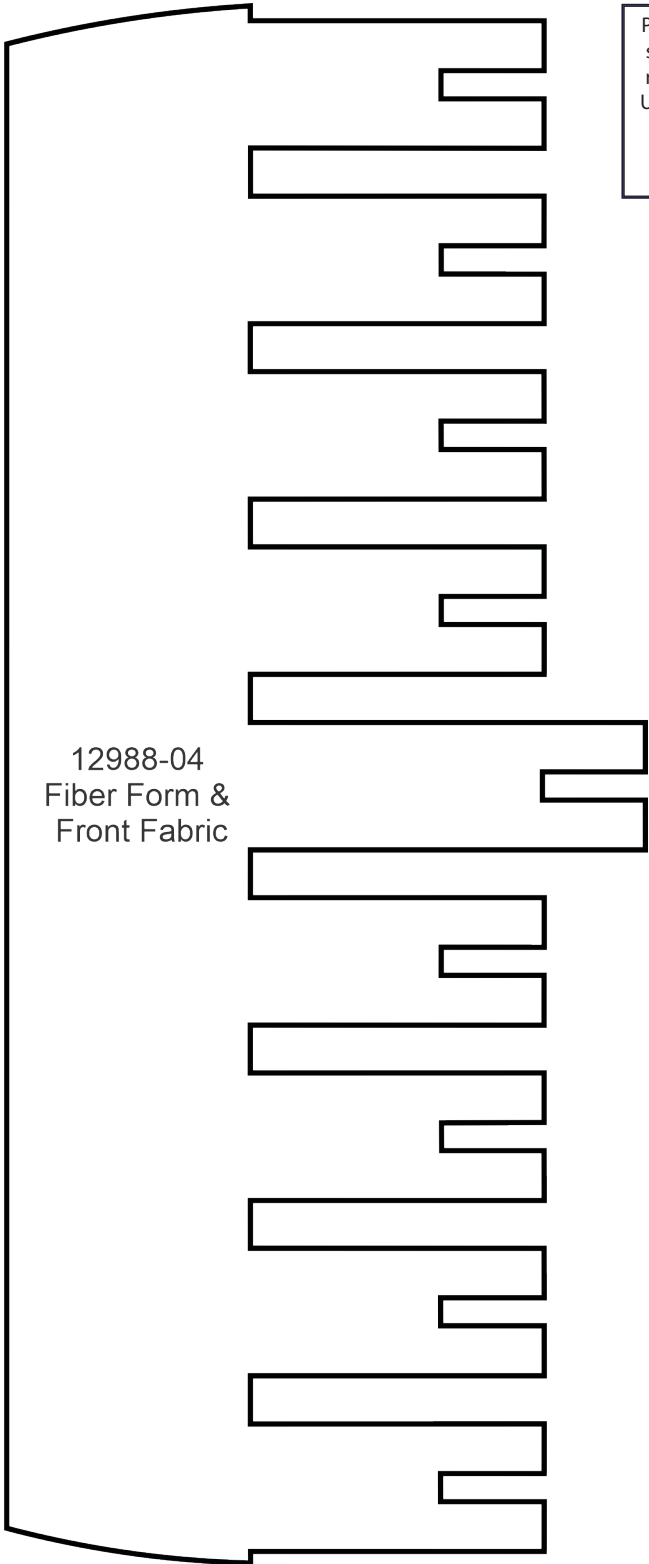

12988-04  
Fiber Form &  
Front Fabric

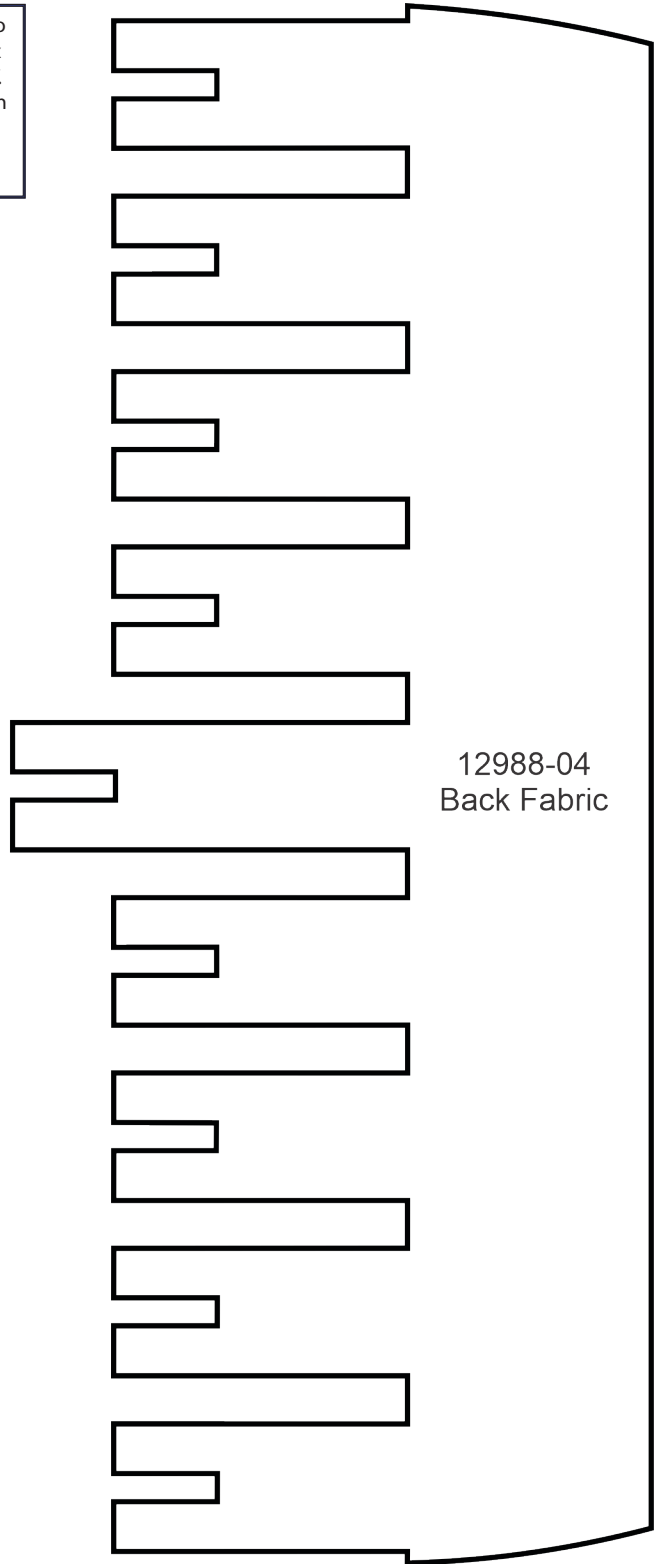

12988-04  
Back Fabric

# APPLIQUE PATTERNS

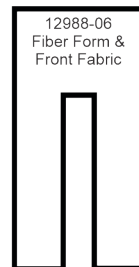
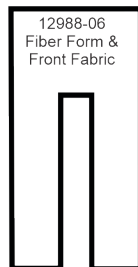
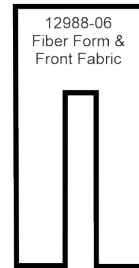
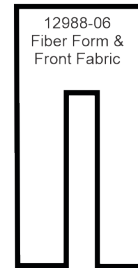
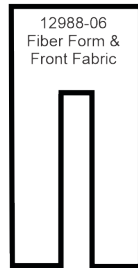
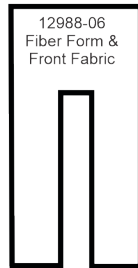

Print at 100%. No scaling. This box measures 1" x 1". Use the box as an accuracy guide when printing templates.

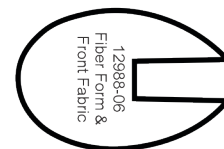
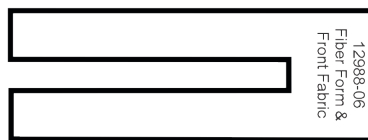
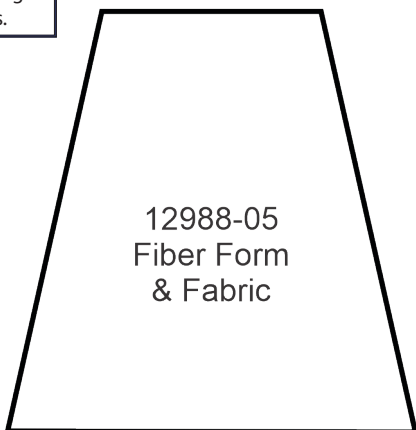

# APPLIQUE PATTERNS

Print at 100%. No scaling. This box measures 1" x 1". Use the box as an accuracy guide when printing templates.

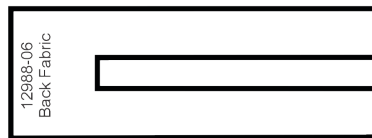
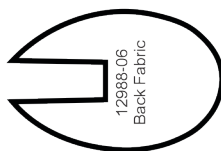
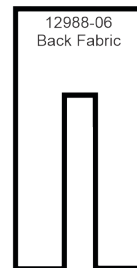
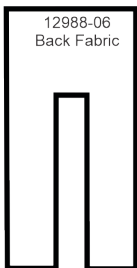
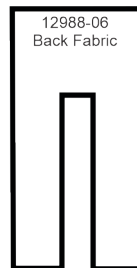
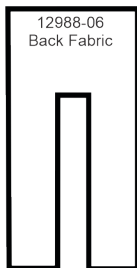
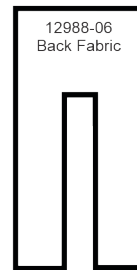
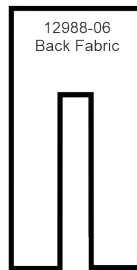
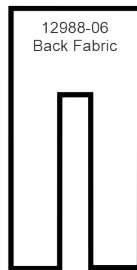
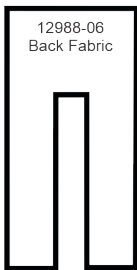

# APPLIQUE PATTERNS



Print at 100%. No scaling. This box measures 1" x 1". Use the box as an accuracy guide when printing templates.

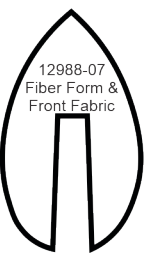
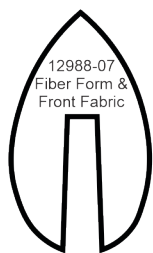
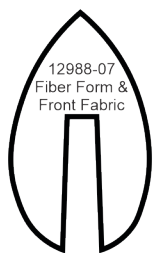
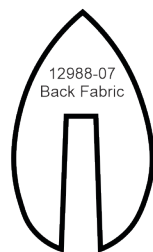
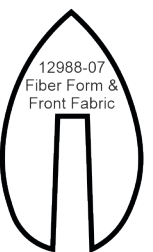
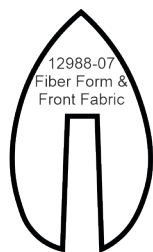
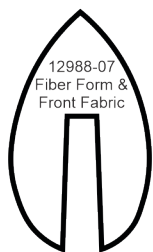
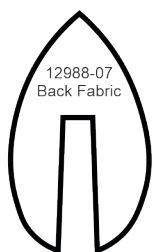
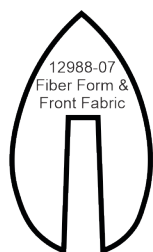
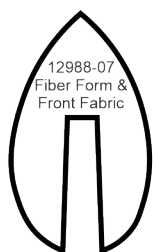
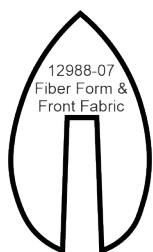



# APPLIQUE PATTERNS

Print at 100%. No scaling. This box measures 1" x 1". Use the box as an accuracy guide when printing templates.

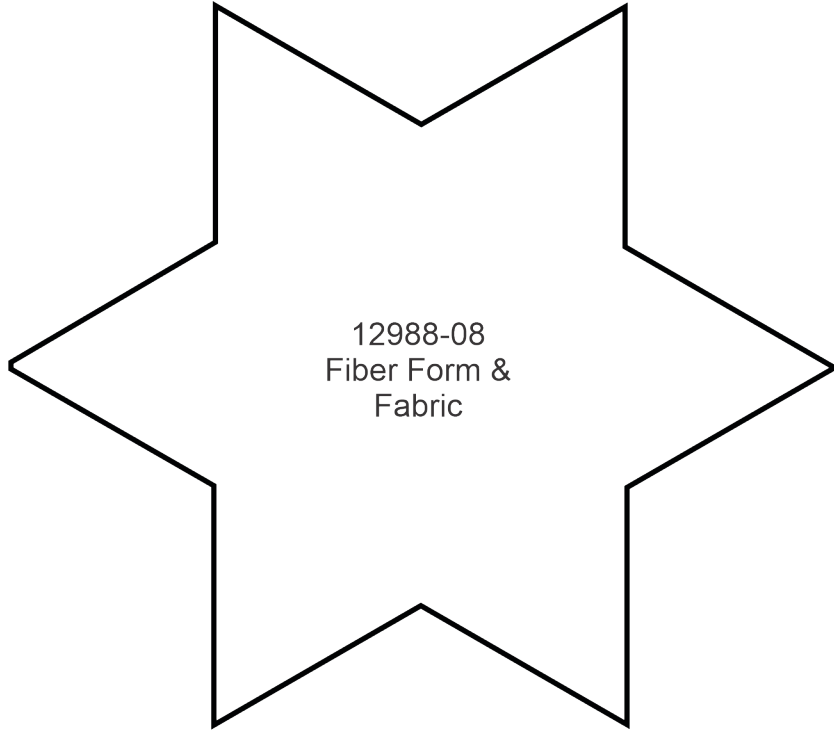

12988-08  
Fiber Form &  
Fabric

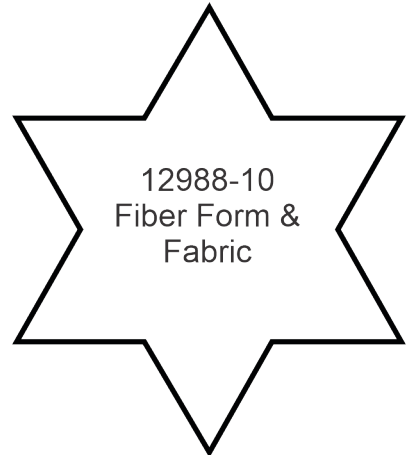

12988-10  
Fiber Form &  
Fabric

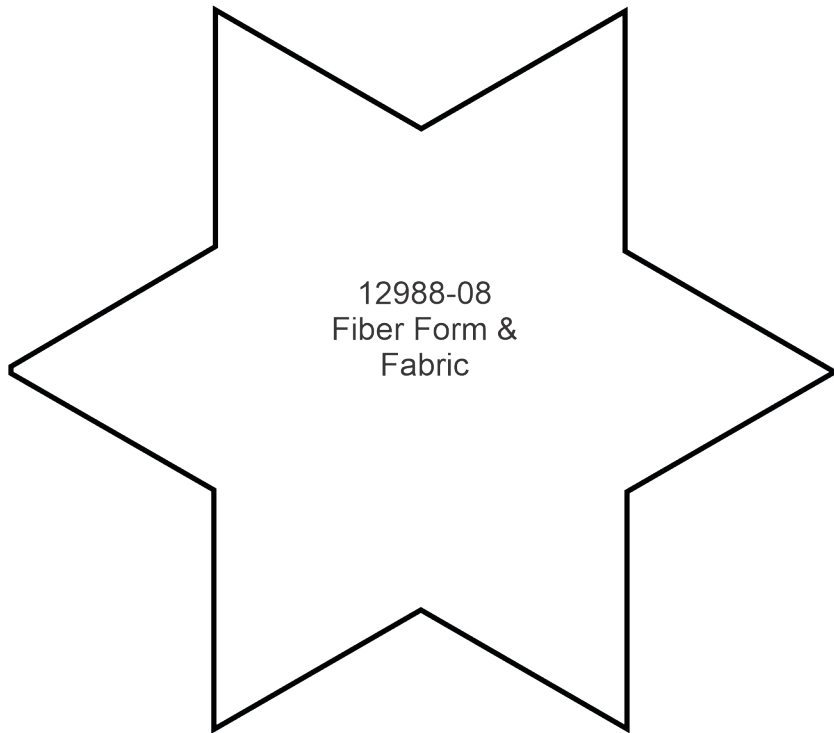

12988-08  
Fiber Form &  
Fabric

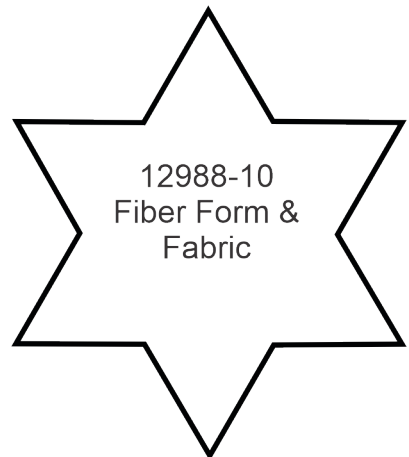

12988-10  
Fiber Form &  
Fabric

MIRRORED PATTERNS  **PREMIER**  
COLLECTION

Print at 100%. No scaling. This box measures 1" x 1". Use the box as an accuracy guide when printing templates.

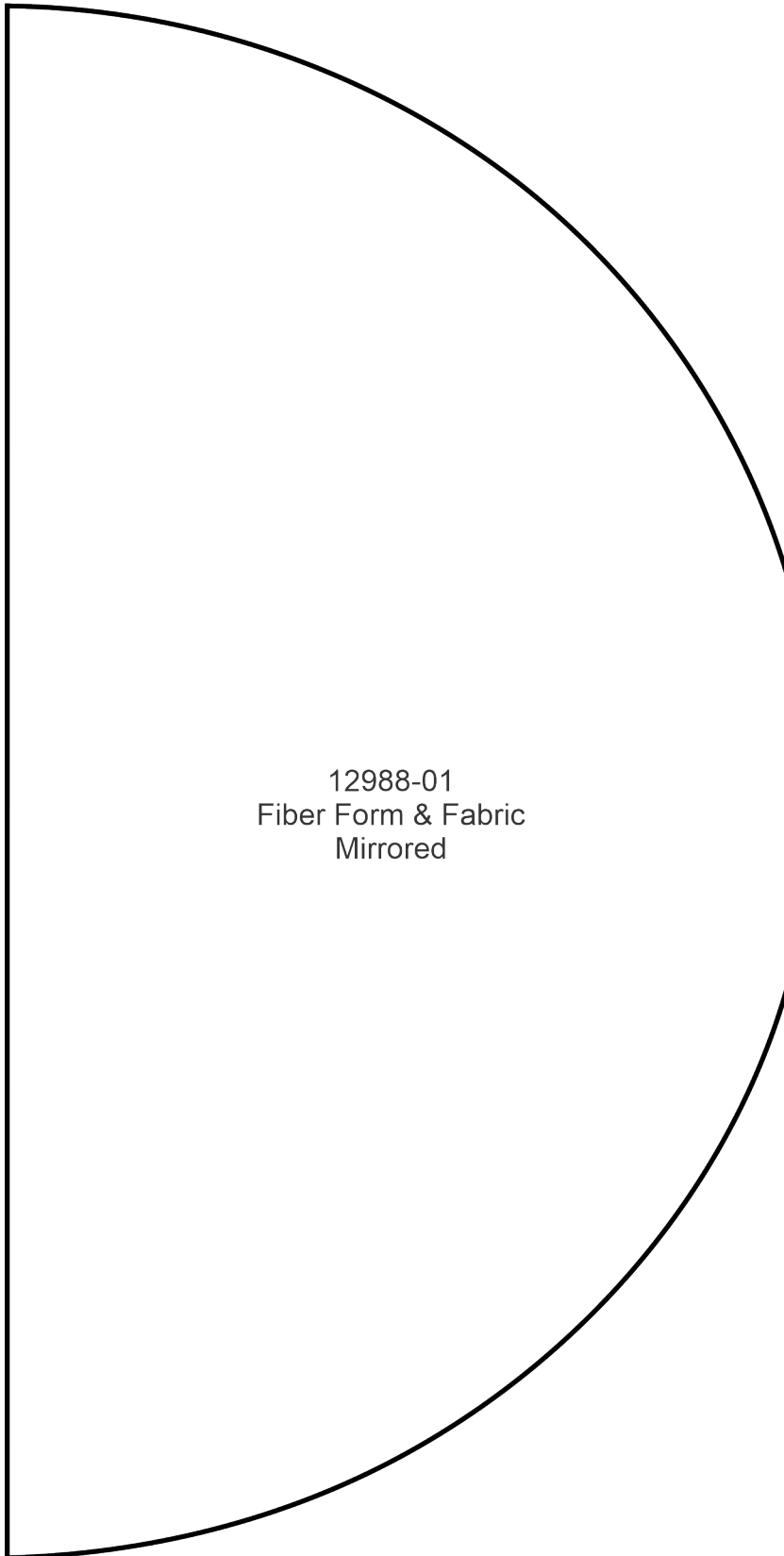

12988-01  
Fiber Form & Fabric  
Mirrored

# MIRRORED PATTERNS

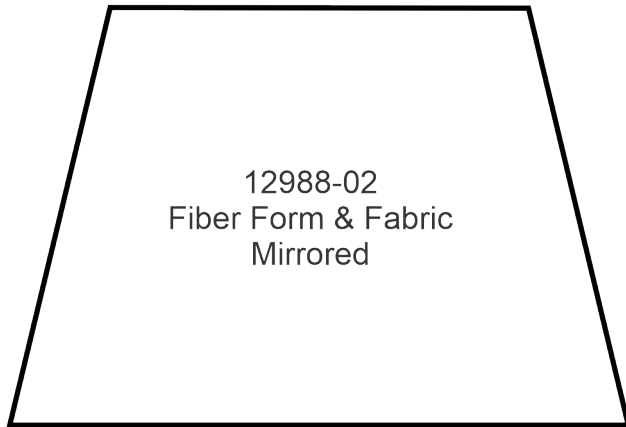
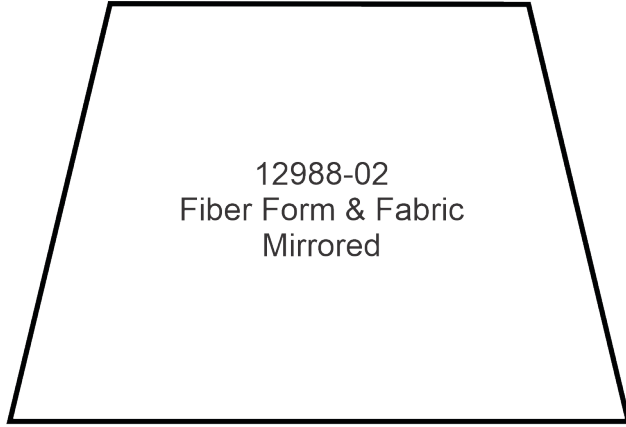

Print at 100%. No scaling. This box measures 1" x 1". Use the box as an accuracy guide when printing templates.

# MIRRORED PATTERNS



Print at 100%. No scaling. This box measures 1" x 1". Use the box as an accuracy guide when printing templates.

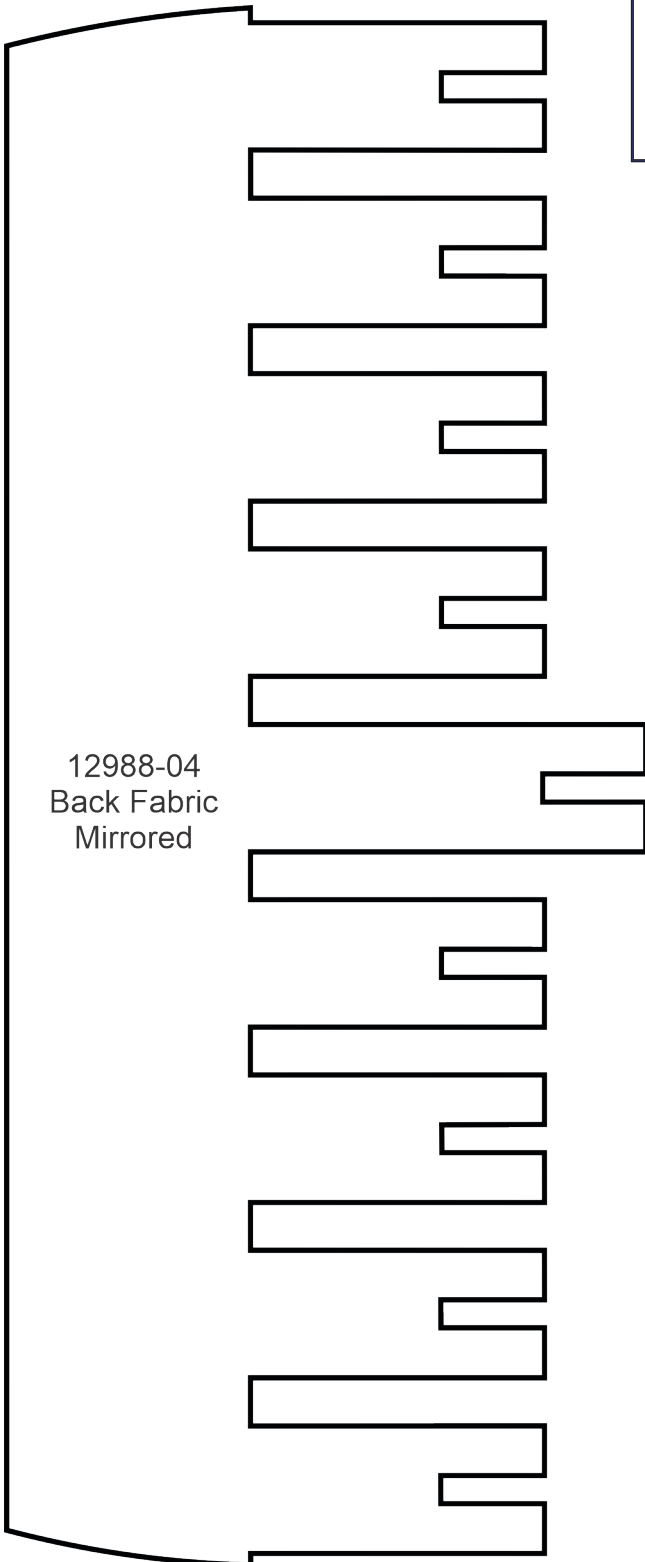

12988-04  
Back Fabric  
Mirrored

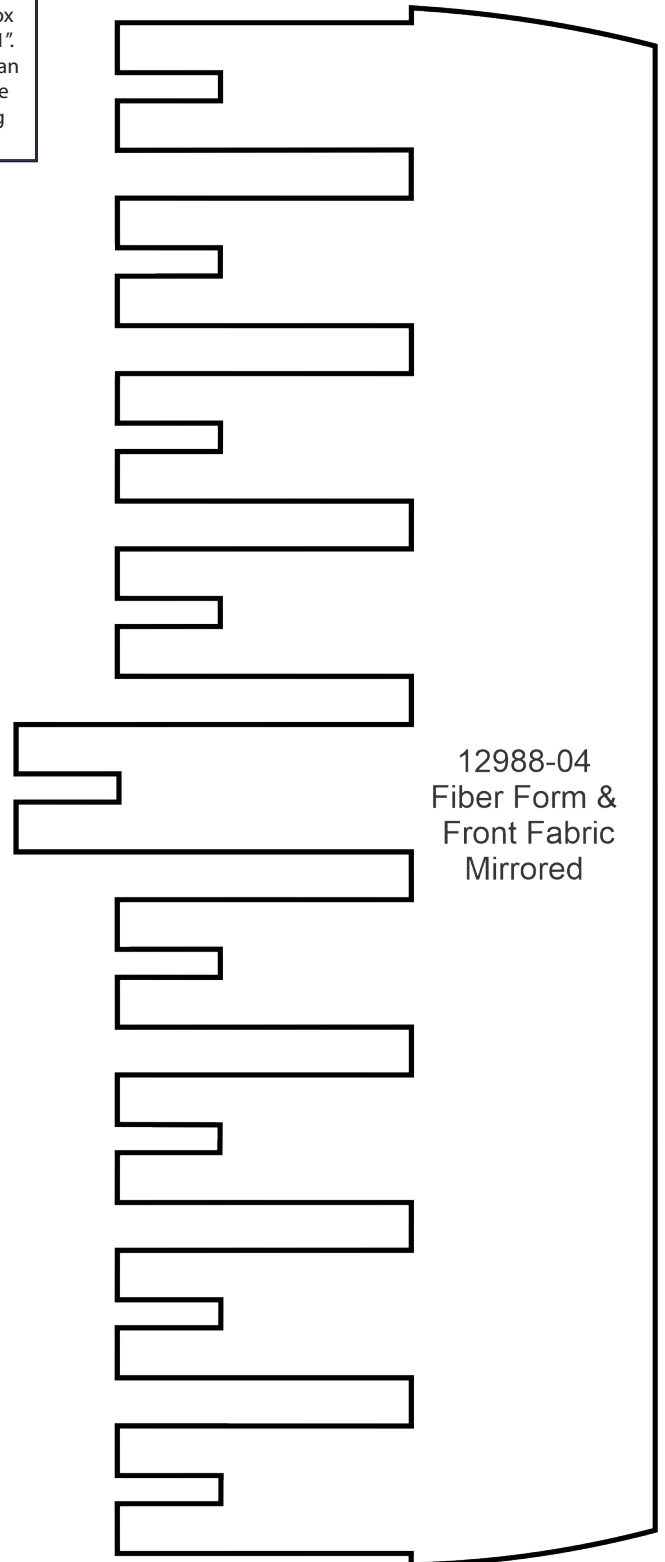

12988-04  
Fiber Form &  
Front Fabric  
Mirrored

# MIRRORED PATTERNS

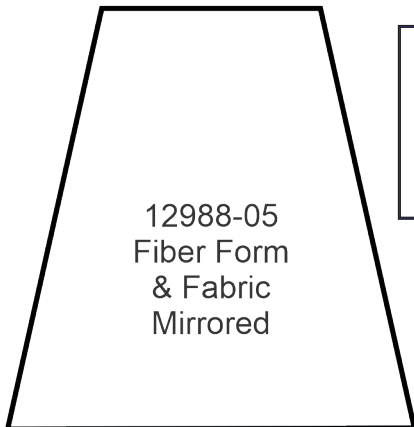
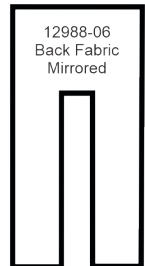
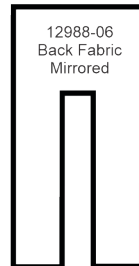
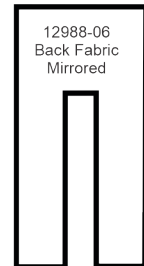
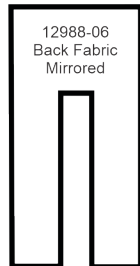
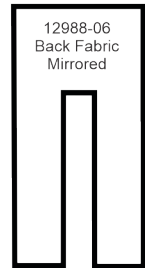
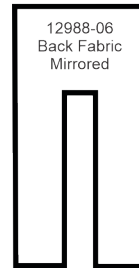
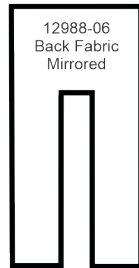
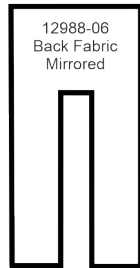

Print at 100%. No scaling. This box measures 1" x 1". Use the box as an accuracy guide when printing templates.

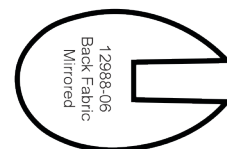
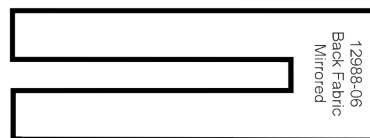



# MIRRORED PATTERNS



Print at 100%. No scaling. This box measures 1" x 1". Use the box as an accuracy guide when printing templates.

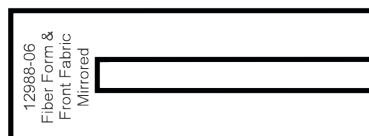
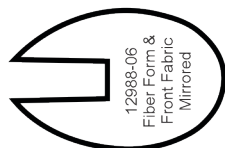
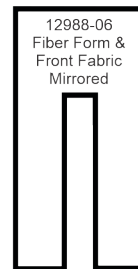
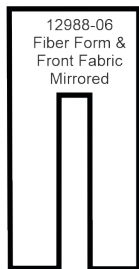
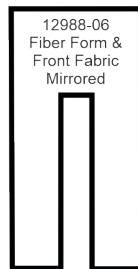
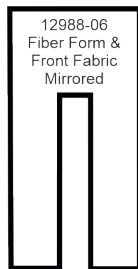
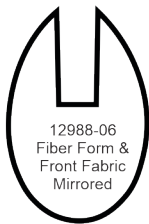
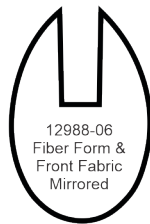
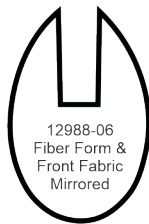
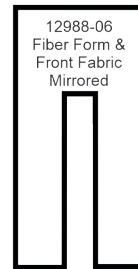
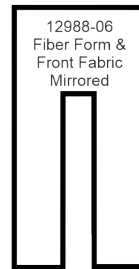
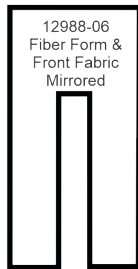
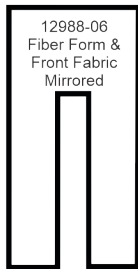
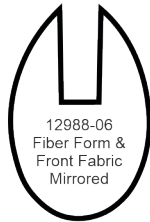
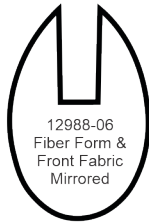

# MIRRORED PATTERNS PREMIER COLLECTION

Print at 100%. No scaling. This box measures 1" x 1". Use the box as an accuracy guide when printing templates.

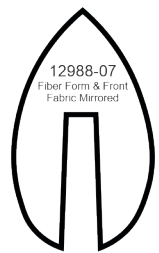
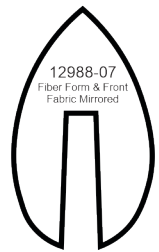
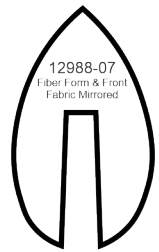

# MIRRORED PATTERNS

Print at 100%. No scaling. This box measures 1" x 1". Use the box as an accuracy guide when printing templates.

