



# Freestanding Desk Set Trio



Collection No. 13043  
3 Designs/13 Files

## Isacord Thread Colors

---

- 0015 White
- 1030 Passion Fruit
- 2171 Blush
- 2532 Pretty in Pink
- 4952 Mystic Ocean

 **Note: One spool of 1000 meter thread is adequate for the project unless otherwise noted.**

## Stabilizers

- OESD AquaMesh WashAway
- OESD BadgeMaster WashAway
- OESD SoftWeb
- OESD Fiber Form
- OESD Applique Fuse and Fix

## Fabrics/Textiles

- OESD Clear Vinyl
- Aqua Quilter's Cotton
- Light Pink Quilter's Cotton
- Pink Quilter's Cotton
- Orange Quilter's Cotton

## Notion & Tools

- OESD Grippy Grid
- OESD Expert Embroidery Tape TearAway
- OESD Expert Embroidery Tape WashAway
- OESD Perfect Embroidery Press Cloth
- OESD Perfect Scoring Tool
- OESD Perfect Punch Tool
- OESD MiniMat
- OESD Alligator Clamps
- OESD Button Clips
- Embroidery Needle Sharp 75/11

## Thread Colors

- Per thread chart



**Completed Size:**

Organizer: 6" L x 6" W x 5" H

13043-01



Design Size:  
5.18 X 3.63 in.

13043-02



Design Size:  
8.40 X 3.93 in.

13043-03



Design Size:  
5.19 X 4.24 in.

13043-04

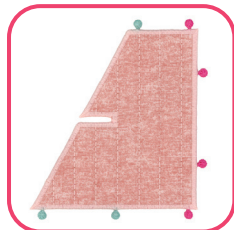

Design Size:  
5.60 X 4.98 in.

13043-05

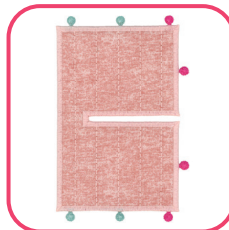

Design Size:  
5.59 X 3.64 in.

13043-06

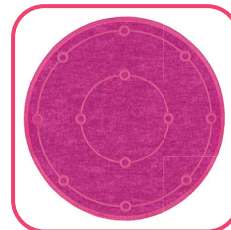

Design Size:  
5.91 X 5.92 in.



**Completed Size:**

Frame: 7 3/4" L x 3" W x 5 1/4" H

13043-07



Design Size:  
6.89 X 5.47 in.

13043-08

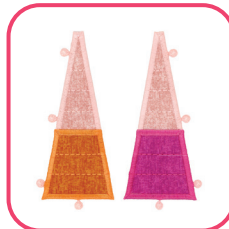

Design Size:  
5.01 X 4.86 in.

13043-09

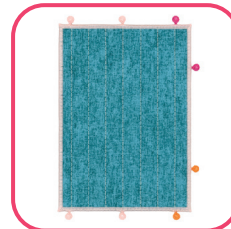

Design Size:  
6.97 X 4.86 in.

13043-10

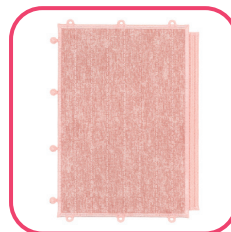

Design Size:  
7.24 X 5.45 in.

13043-11

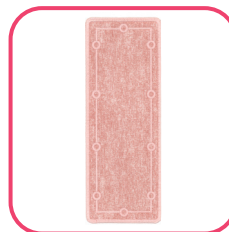

Design Size:  
7.74 X 2.94 in.

# SUMMARY - BUSINESS CARD HOLDER

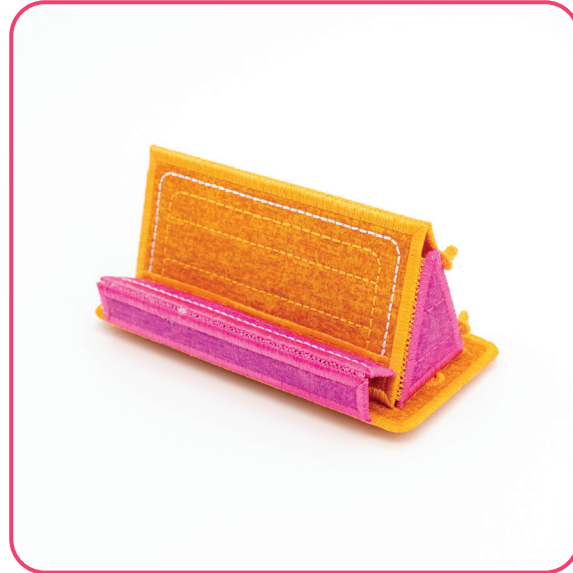

## Completed Size:

Business Card Holder: 5 1/4" L x 2 1/2" W x 2 1/2" H

13043-12

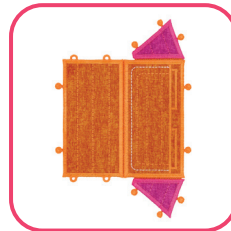

Design Size:  
7.30 X 5.13 in.

13043-13

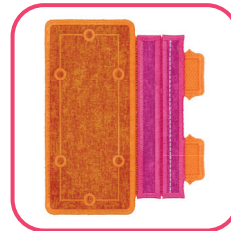

Design Size:  
5.21 X 4.34 in.

## GENERAL INSTRUCTIONS

The freestanding applique (FSA) instructions, included in the collection, are general instructions. For demonstration purposes, a sample design that best demonstrates the technique is shown. Designs 13043-07 and 13043-12 are shown here. Fabric and thread requirements will vary by design, but the general technique is the same. Applique techniques shown are pre-cut (Fiber Form) and cut in place (fabric & vinyl). Pre-cut applique patterns are included at the end of the instructions.

**Note: Some thread colors in the instructions have been changed or digitally enhanced for better visibility.**

### Designs - Single Sided Applique

Organizer Base FSA	13043-06
Frame Sides FSA	13043-08
Frame Back FSA	13043-10
Frame Base FSA	13043-11
Business Card Holder Walls FSA	13043-12

### Step 1

- Print the mirrored version of the applique patterns (at 100% scale or 1:1 ratio) onto the paper side of Applique Fuse and Fix. The applique patterns are included at the end of the instructions.
- Cut approximately 1/4" - 1/2" outside the printed applique patterns.

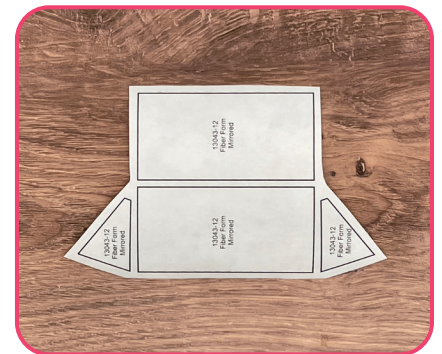

## Step 2

- Cut the Fiber Form 1/4" - 1/2" larger than the applique patterns.
- Fuse the trimmed patterns to the back of the Fiber Form with the paper side of the printed patterns up. Hold the iron on the pattern for 10-15 seconds for a secure fuse.



## Step 3

- Trim the Fiber Form on the outer edges of the black outline.
- Set aside.

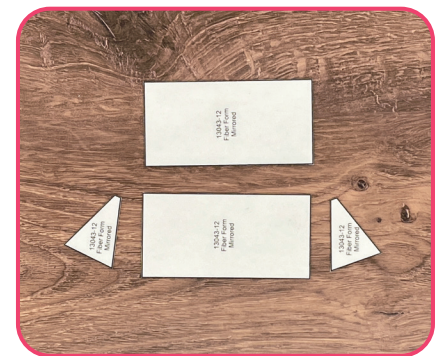

## Step 4

- Cut the applique fabrics 1/4" - 1/2" larger than the applique patterns.
- Fuse one layer of SoftWeb to the wrong side of all applique fabrics to provide some body to the fabric.



## Step 5

- Using the OEESD Grippy Grid, hoop one layer of Aquamesh and one layer of BadgeMaster for all designs.

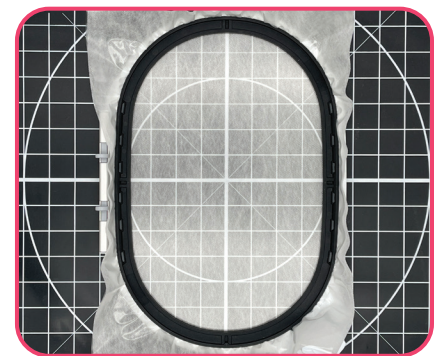

## Step 6

- Load the selected design into the machine.
- Example design is 13043-12.
- Thread the machine per the thread chart.
- Place the hoop on the machine.
- Stitch Machine Step 1, Fiber Form and Front Pink Fabric Placement Stitch.



## Step 7

- Remove the hoop from the machine, but NOT the project from the hoop.
- Place the hoop on a flat surface.
- On the back of the Fiber Form, use the OESD Perfect Scoring Tool to score and remove the paper backing to reveal the adhesive surface.
- Place the Fiber Form within the placement stitching.
- Finger press to secure.

**Tip: Applique Fuse and Fix is repositionable.**



## Step 8

- Remove the paper backing off the SoftWeb on the pink applique fabric.
- Completely cover the Fiber Form with the prepared pink applique fabric.
- Tape in place with OESD Expert Embroidery Tape TearAway to secure.

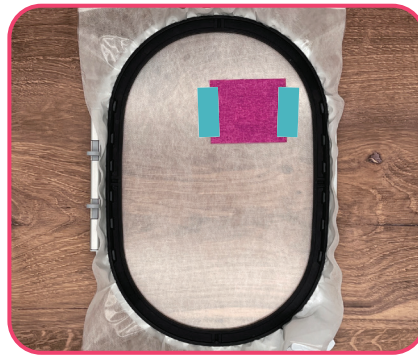

## Step 9

- Return the hoop to the machine.
- Stitch Machine Step 2, Cut Line and Tackdown.



## Step 10

- Remove the hoop from the machine, but NOT the project from the hoop.
- Trim the excess fabric as close to the cut line as possible. If the outermost stitches (cut line) are cut, the inner stitches (tackdown) will hold the applique in place.

**Tip: If the stabilizer is cut or a hole is created while trimming the fabric, use OESD Expert Embroidery Tape WashAway as a patch.**



## Step 11

- Return the hoop to the machine.
- Stitch Machine Step 3, Fiber Form and Front Pink Fabric Placement Stitch.



## Step 12

- Remove the hoop from the machine, but NOT the project from the hoop.
- Place the hoop on a flat surface.
- On the back of the Fiber Form, score and remove the paper backing to reveal the adhesive surface.
- Place the Fiber Form within the placement stitching.
- Finger press to secure.

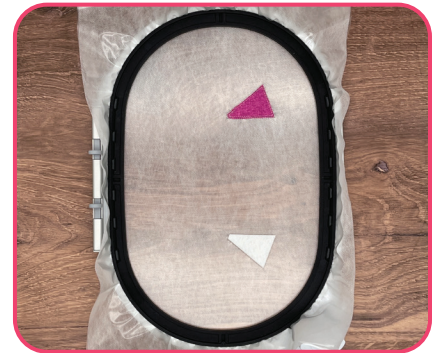

## Step 13

- Remove the paper backing off the SoftWeb on the pink applique fabric.
- Completely cover the Fiber Form with the prepared pink applique fabric.
- Tape in place to secure.

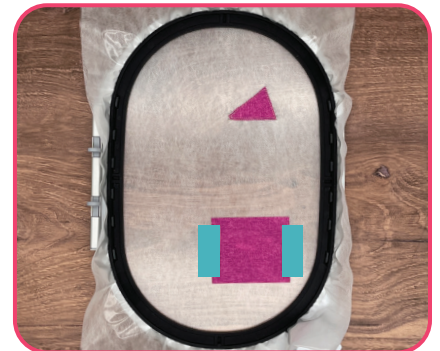

## Step 14

- Return the hoop to the machine.
- Stitch Machine Step 4, Cut Line and Tackdown.



## Step 15

- Remove the hoop from the machine, but NOT the project from the hoop.
- Trim the excess fabric as close to the cut line as possible.



## Step 16

- Return the hoop to the machine.
- Stitch Machine Step 5, Fiber Form and Front Orange Fabric Placement Stitch.

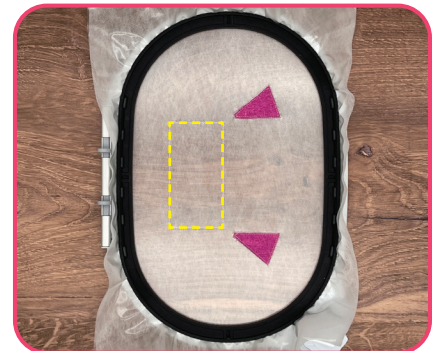

## Step 17

- Remove the hoop from the machine, but NOT the project from the hoop.
- Place the hoop on a flat surface.
- On the back of the Fiber Form, score and remove the paper backing to reveal the adhesive surface.
- Place the Fiber Form within the placement stitching.
- Finger press to secure.



## Step 18

- Remove the paper backing off the SoftWeb on the orange applique fabric.
- Completely cover the Fiber Form with the prepared orange applique fabric.
- Tape in place to secure.

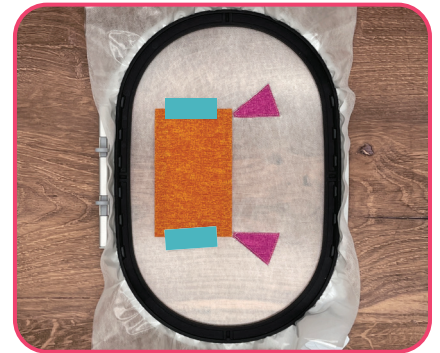

## Step 19

- Return the hoop to the machine.
- Stitch Machine Step 6, Cut Line and Tackdown.

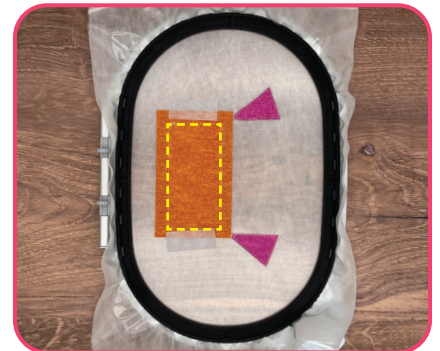

## Step 20

- Remove the hoop from the machine, but NOT the project from the hoop.
- Trim the excess fabric as close to the cut line as possible.



## Step 21

- Return the hoop to the machine.
- Stitch Machine Step 7, Fiber Form and Front Orange Fabric Placement Stitch.

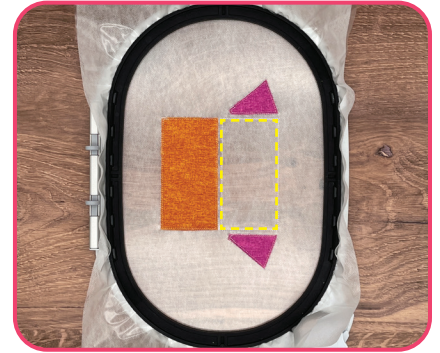

## Step 22

- Remove the hoop from the machine, but NOT the project from the hoop.
- Place the hoop on a flat surface.
- On the back of the Fiber Form, score and remove the paper backing to reveal the adhesive surface.
- Place the Fiber Form within the placement stitching.
- Finger press to secure.



## Step 23

- Remove the paper backing off the SoftWeb on the orange applique fabric.
- Completely cover the Fiber Form with the prepared orange applique fabric.
- Tape in place to secure.



## Step 24

- Return the hoop to the machine.
- Stitch Machine Step 8, Cut Line and Tackdown.

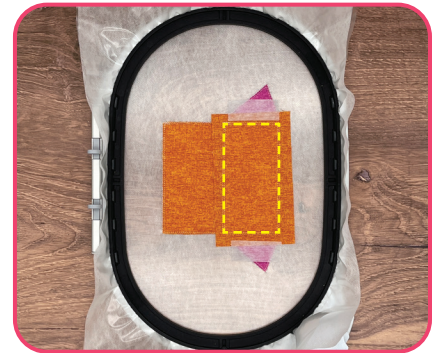

## Step 25

- Remove the hoop from the machine, but NOT the project from the hoop.
- Trim the excess fabric as close to the cut line as possible.

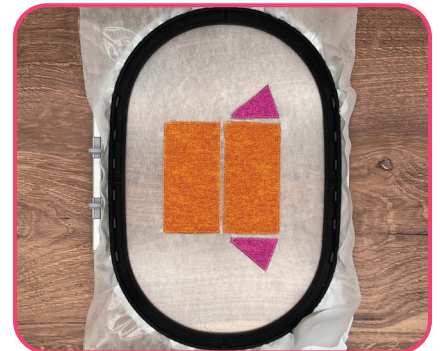

## Step 26

- Return the hoop to the machine.
- Stitch the remaining machine steps per the thread chart **with matching bobbin thread.**

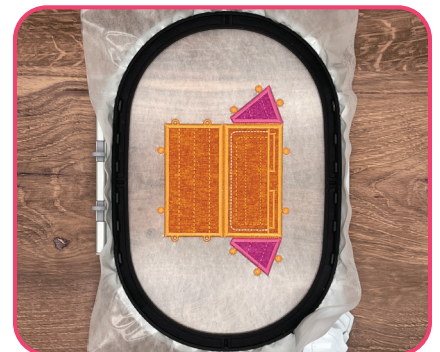

## □ Step 27

- When the design is complete, remove the project from the hoop.
- Trim the stabilizer 1/4" - 1/2" outside the design.

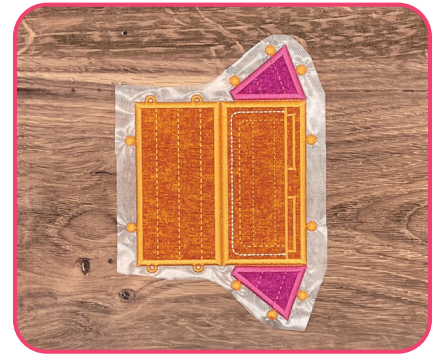

## Designs - Double Sided Applique

Organizer Wall 1 FSA	13043-01
Organizer Wall 2 FSA	13043-02
Organizer Wall 3 FSA	13043-03
Organizer Divider 1 FSA	13043-04
Organizer Divider 2 FSA	13043-05
Frame Front FSA	13043-07
Frame Background FSA	13043-09
Business Card Holder Base & Shelf FSA	13043-13

## Step 28

- Print the mirrored version of the applique patterns (at 100% scale or 1:1 ratio) onto the paper side of Applique Fuse and Fix. The applique patterns are included at the end of the instructions.
- Cut approximately 1/4" - 1/2" outside the printed applique patterns.

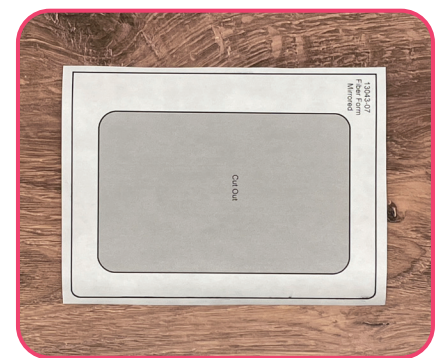

## Step 29

- Cut the Fiber Form 1/4" - 1/2" larger than the applique patterns.
- Fuse the trimmed patterns to the back of the Fiber Form with the paper side of the printed patterns up. Hold the iron on the pattern for 10-15 seconds for a secure fuse.



## Step 30

- Trim the Fiber Form on the outer edges of the black outline.
- Set aside.

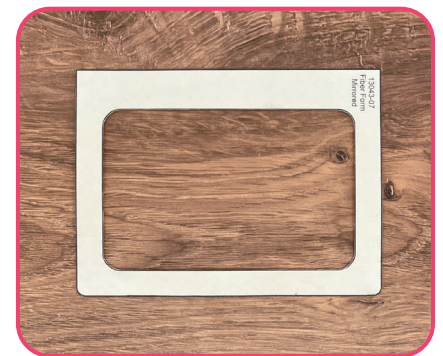

## Step 31

- Cut the prepared applique fabrics 1/4" - 1/2" larger than the applique patterns.
- Fuse one layer of SoftWeb to the wrong side of all applique fabrics to provide some body to the fabric.

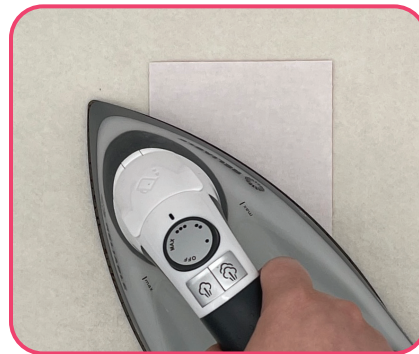

## Step 32

- Using the OEESD Grippy Grid, hoop one layer of Aquamesh and one layer of BadgeMaster for all designs.

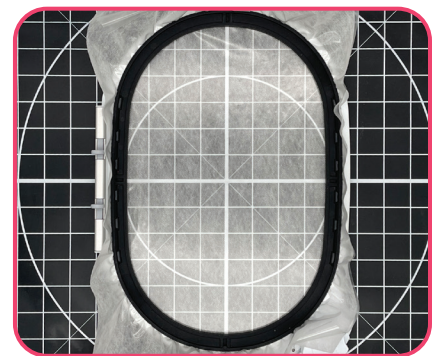

## Step 33

- Load the selected design into the machine.
- Example design is 13043-07.
- Thread the machine per the thread chart.
- Place the hoop on the machine.
- Stitch Machine Step 1, Fiber Form Placement Stitch.

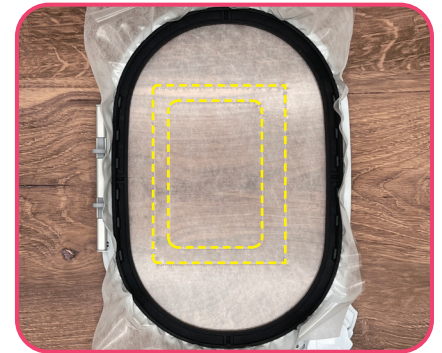

## Step 34

- Remove the hoop from the machine, but NOT the project from the hoop.
- Place the hoop on a flat surface.
- On the back of the Fiber Form, use the OESD Perfect Scoring Tool to score and remove the paper backing to reveal the adhesive surface.
- Place the Fiber Form within the placement stitching.
- Finger press to secure.

**Tip: Applique Fuse and Fix is repositionable.**

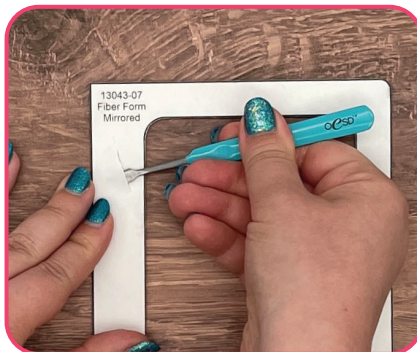

## Step 35

- Return the hoop to the machine.
- Stitch Machine Step 2, Cut Line and Tackdown.
- Stitch Machine Step 3, Front and Back Light Pink Fabric Placement Stitch.

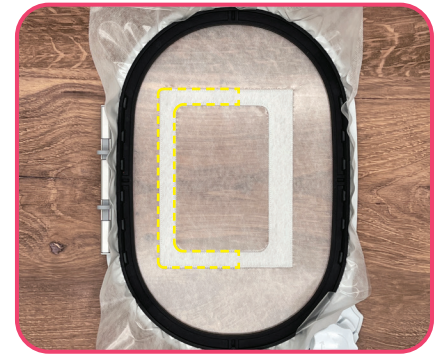

## Step 36

- Remove the paper backing off the SoftWeb on the light pink applique fabric.
- Completely cover the Fiber Form with the prepared light pink applique fabric.
- Tape in place with OESD Expert Embroidery Tape TearAway to secure.



## Step 37

- Turn the hoop over and place the prepared light pink applique fabric, right side up, completely covering the placement stitch.
- Carefully tape to secure.

 **Tip: Avoid pushing too hard on the stabilizer to prevent it from dislodging from the hoop.**



## Step 38

- Return the hoop to the machine.
- Stitch Machine Step 4, Cut Line and Tackdown.

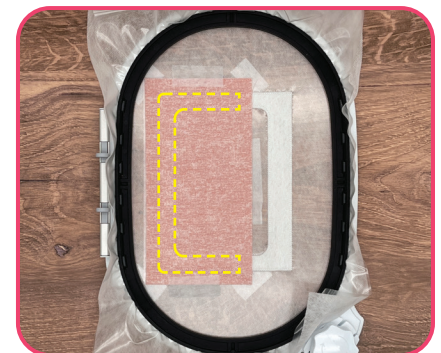

## Step 39

- Remove the hoop from the machine, but NOT the project from the hoop.
- Trim the excess fabric as close to the cut line as possible. If the outermost stitches (cut line) are cut, the inner stitches (tackdown) will hold the applique in place.

 **Tip: If the stabilizer is cut or a hole is created while trimming the fabric, use OESD Expert Embroidery Tape WashAway as a patch.**



## Step 40

- Turn the hoop over. Trim the excess fabric as close to the cut line as possible.



## Step 41

- Return the hoop to the machine.
- Stitch Machine Step 5, Front and Back Pink Fabric Placement Stitch.

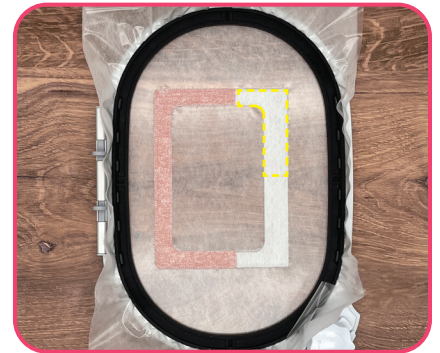

## Step 42

- Remove the hoop from the machine, but NOT the project from the hoop.
- Place the hoop on a flat surface.
- Remove the paper backing off the SoftWeb on the pink applique fabrics.
- Completely cover the placement stitch with the prepared pink applique fabric.
- Tape in place to secure.



## Step 43

- Turn the hoop over and place the prepared pink applique fabric, right side up, completely covering the placement stitch.
- Carefully tape to secure.

 **Tip: Avoid pushing too hard on the stabilizer to prevent it from dislodging from the hoop.**



## Step 44

- Return the hoop to the machine.
- Stitch Machine Step 6, Cut Line and Tackdown.



## Step 45

- Remove the hoop from the machine, but NOT the project from the hoop.
- Trim the excess fabric as close to the cut line as possible.



## Step 46

- Turn the hoop over. Trim the excess fabric as close to the cut line as possible.



## Step 47

- Return the hoop to the machine.
- Stitch Machine Step 7, Front and Back Orange Fabric Placement Stitch.



## Step 48

- Remove the hoop from the machine, but NOT the project from the hoop.
- Place the hoop on a flat surface.
- Remove the paper backing off the SoftWeb on the orange applique fabrics.
- Completely cover the placement stitch with the prepared orange applique fabric.
- Tape in place to secure.



## Step 49

- Turn the hoop over and place the prepared orange applique fabric, right side up, completely covering the placement stitch.
- Carefully tape to secure.

 **Tip: Avoid pushing too hard on the stabilizer to prevent it from dislodging from the hoop.**



## Step 50

- Return the hoop to the machine.
- Stitch Machine Step 8, Cut Line and Tackdown.

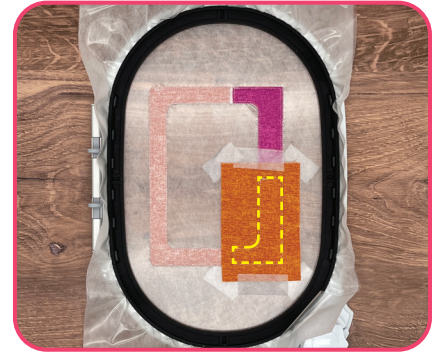

## Step 51

- Remove the hoop from the machine, but NOT the project from the hoop.
- Trim the excess fabric as close to the cut line as possible.



## Step 52

- Turn the hoop over. Trim the excess fabric as close to the cut line as possible.



## Step 53

- Return the hoop to the machine.
- Stitch Machine Step 9, Clear Vinyl Placement Stitch.



## Step 54

- Remove the hoop from the machine, but NOT the project from the hoop.
- Place the hoop on a flat surface.
- Completely cover the placement stitch with the clear vinyl.
- Tape in place to secure.



## Step 55

- Return the hoop to the machine.
- Stitch Machine Step 10, Cut Line and Tackdown.

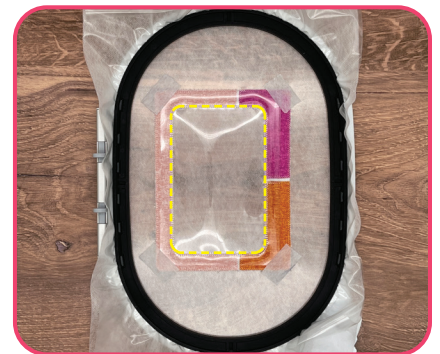

## Step 56

- Remove the hoop from the machine, but NOT the project from the hoop.
- Trim the excess vinyl as close to the cut line as possible.



## Step 57

- Return the hoop to the machine.
- Stitch the remaining machine steps per the thread chart **with matching bobbin thread**.



## Step 58

- When the design is complete, remove the project from the hoop.
- Trim the stabilizer 1/4" - 1/2" outside the design.

**Tip: Carefully, trim the stabilizer away from the vinyl before rinsing.**



## □ Step 59

- Rinse each piece in warm running water until the design is only slightly tacky.
- Place right side down on a non-stick surface to dry. Parchment paper or a cooling rack work well. Dry completely.
- Once dry, press right side down on an OESD Perfect Embroidery Press Cloth.



✓ **Note: Using the Perfect Embroidery Press Cloth when pressing your design helps prevent the stitches from becoming crushed and absorbs steam for a perfectly pressed finish.**

## □ Step 60

- Before assembly, use the OESD MiniMAT and the OESD Perfect Punch Tool with the 3mm attachment to create the eyelets indicated in the diagrams.
- Use the OESD MiniMAT and a craft knife to cut through all the layers of the tab entries.
- Reference the Punch Tool Guide on page 44.

🔔 **Tip: Take care to not cut the satin stitching.**



## Step 61

- Line up Organizer Wall 1 FSA (13043-01), Organizer Wall 2 FSA (13043-02), and Organizer Wall 3 FSA (13043-03) to connect.
- Thread the sewing machine with matching thread on top and bobbin.
- Stitch together using a multi-step zigzag stitch.
- Back stitch at the beginning and end to secure.
- Trim thread tails.
- Set aside.

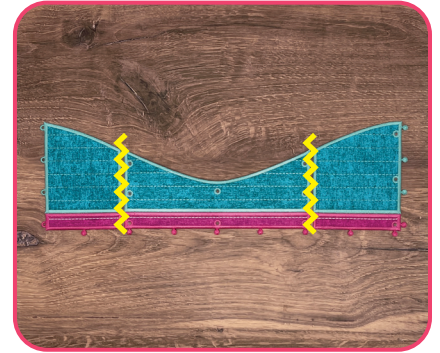

## Step 62

- Use steam to make the Organizer Walls more malleable and shape them into a cylinder shape.

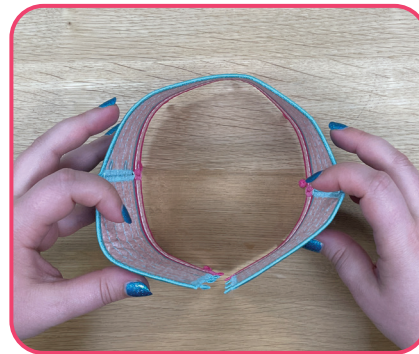
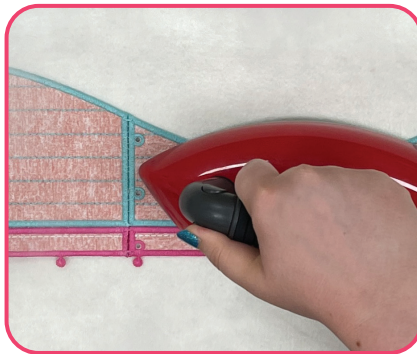

## Step 63

- Match the buttonettes on short side of the Organizer Divider 1 FSA (13043-04) to the middle eyelets on the Organizer Wall 2. The color of the buttonettes will match the color of the eyelets.
- Pull the buttonettes through the corresponding eyelets using Alligator Clamps.

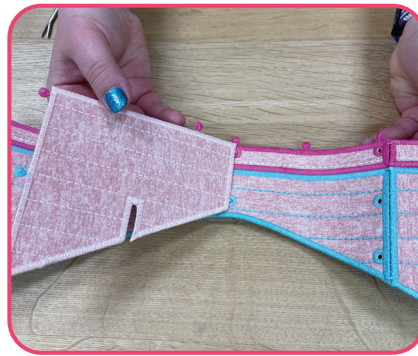
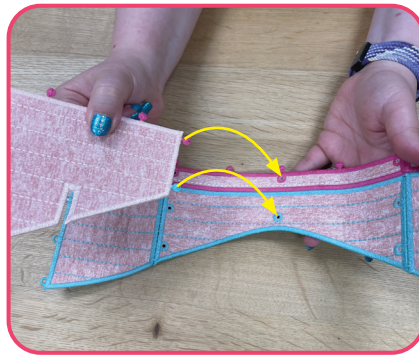

## Step 64

- Slide the Organizer Divider 2 FSA (13043-05) onto the Organizer Divider 1.

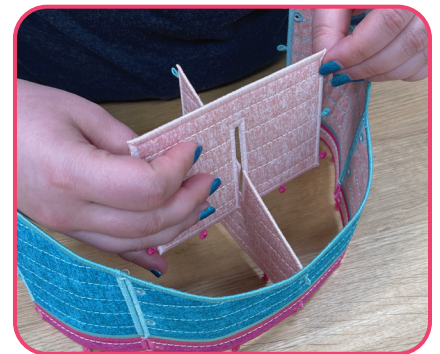

## Step 65

- Match the buttonettes on the left side of the Organizer Divider 2 to the left eyelets on the Organizer Wall 2. The color of the buttonettes will match the color of the eyelets.
- Pull the buttonettes through the corresponding eyelets.

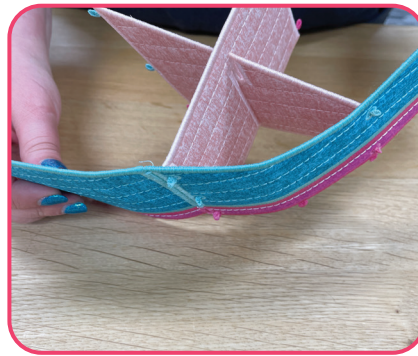
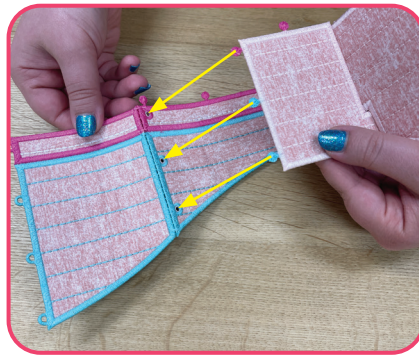

## Step 66

- Match the buttonettes on the right side of the Organizer Divider 2 to the right eyelets on the Organizer Wall 2. The color of the buttonettes will match the color of the eyelets.
- Pull the buttonettes through the corresponding eyelets.

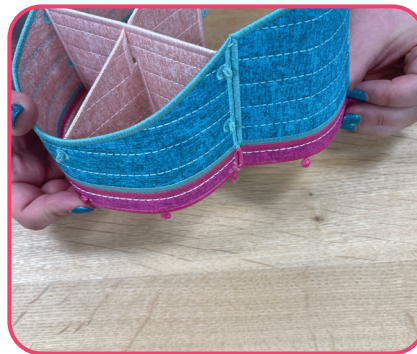
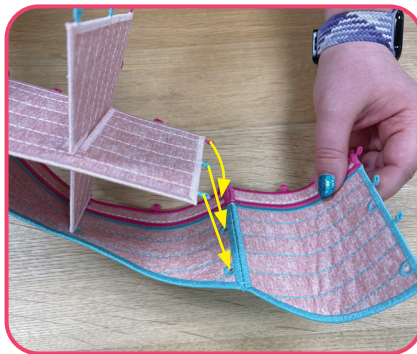

## Step 67

- Match the buttonettes on the tall side of the Organizer Divider 1 to the eyelets on the Organizer Wall 3. The color of the buttonettes will match the color of the eyelets.
- Pull the buttonettes through the corresponding eyelets.

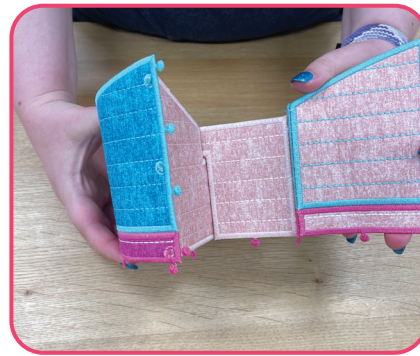
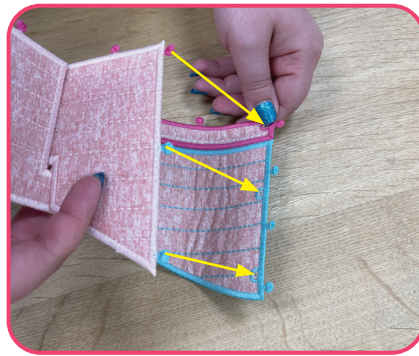

## Step 68

- Match the buttonettes on the Organizer Divider 3 to the eyelets on the Organizer Wall 1. The color of the buttonettes will match the color of the eyelets.
- Pull the buttonettes through the corresponding eyelets.

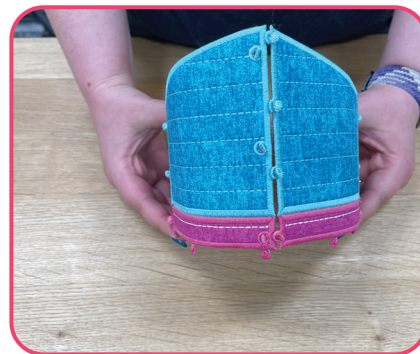
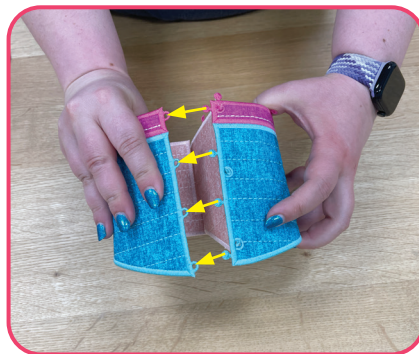

## Step 69

- Match the buttonettes on the Organizer to the eyelets on the Organizer Base FSA (13043-06). The color of the buttonettes will match the color of the eyelets.
- Pull the buttonettes through the corresponding eyelets.

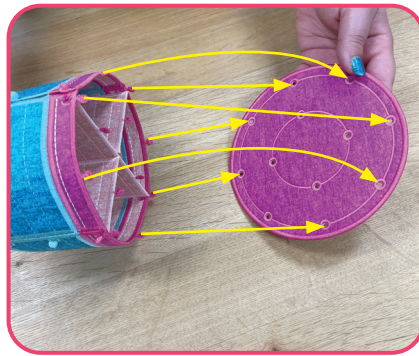

## Step 70

- The Organizer is complete.



## Step 71

- Line up Frame Front FSA (13043-07) and Frame Sides FSA (13043-08) to connect.
- Thread the sewing machine with matching thread on top and bobbin.
- Stitch together using a multi-step zigzag stitch.
- Back stitch at the beginning and end to secure.
- Trim thread tails.
- Set aside.



## Step 72

- Line up Frame Background FSA (13043-09) and Frame Back FSA (13043-10) to connect.
- Stitch together with a multi-step zigzag stitch.

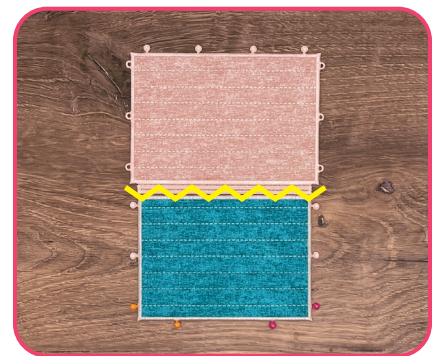

## Step 73

- Match the buttonettes on the Frame Background to the eyelets on the Frame Front. The color of the buttonettes will match the color of the eyelets.
- Pull the buttonettes through the corresponding eyelets using Alligator Clamps.

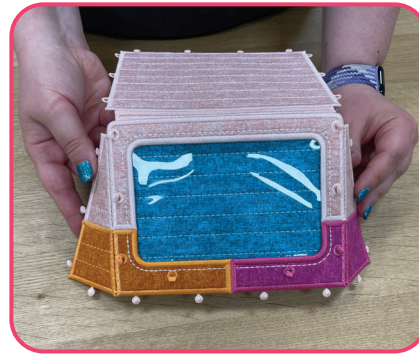
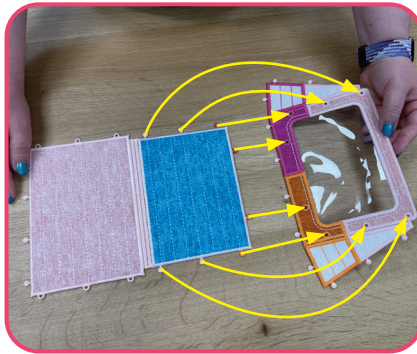

## Step 74

- Match the buttonettes on the Frame Back to the eyelets on the Frame Sides.
- Pull the buttonettes through the corresponding eyelets using Alligator Clamps.

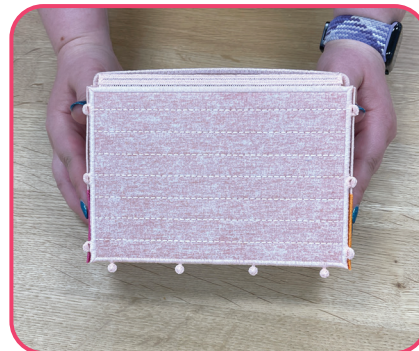
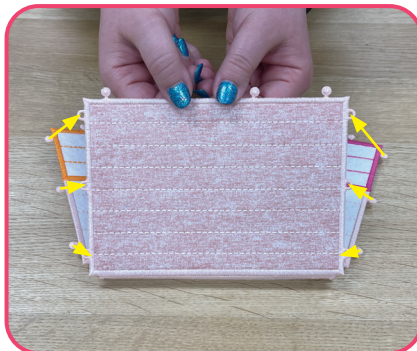

## Step 75

- Match the buttonettes on the Frame to the eyelets on the Frame Base FSA (13043-11).
- Pull the buttonettes through the corresponding eyelets using Alligator Clamps.

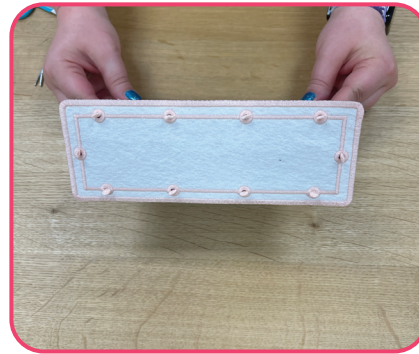
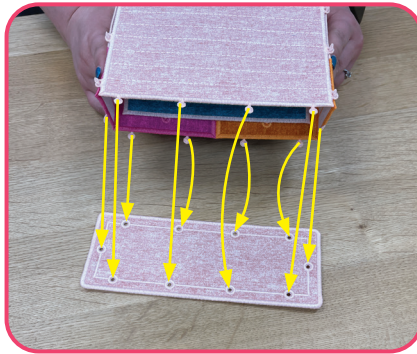

## Step 76

- The Frame is complete.



## Step 77

- Insert the tabs of the Business Card Holder Base & Shelf into the tab entries of the Business Card Holder Walls.

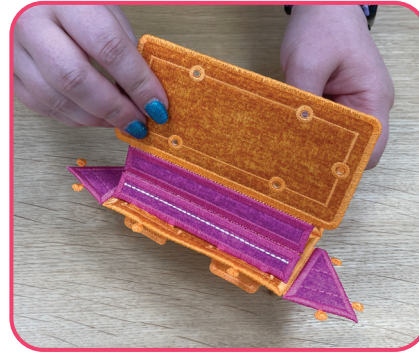
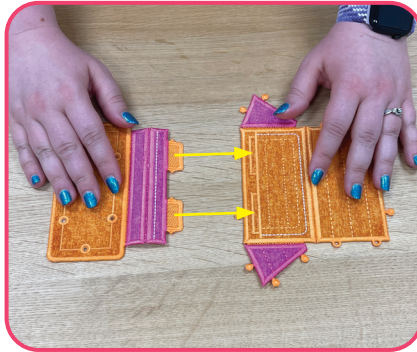

## Step 78

- Match the buttonettes on the front of the Business Card Holder Walls to the eyelets closest to the shelf on the Business Card Holder Base & Shelf.
- Pull the buttonettes through the corresponding eyelets using Alligator Clamps.

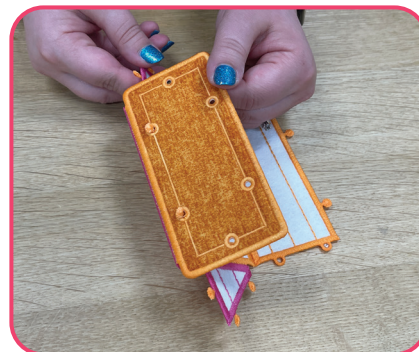
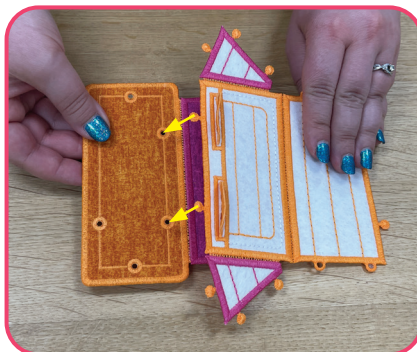

## Step 79

- Fold and match the buttonettes on the bottom sides of the Business Card Holder Walls to the eyelets on the Business Card Holder Base & Shelf.
- Pull the buttonettes through the corresponding eyelets.

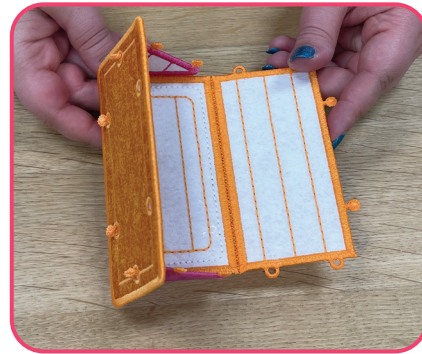
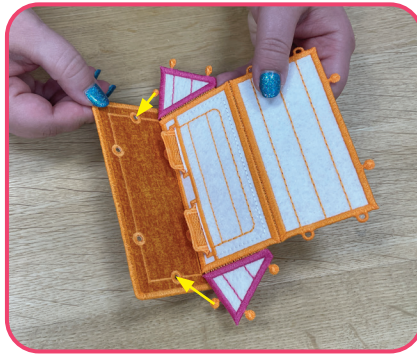

## Step 80

- Fold and match the buttonettes on the sides of the Business Card Holder Walls to the eyelets.
- Pull the buttonettes through the corresponding eyelets.

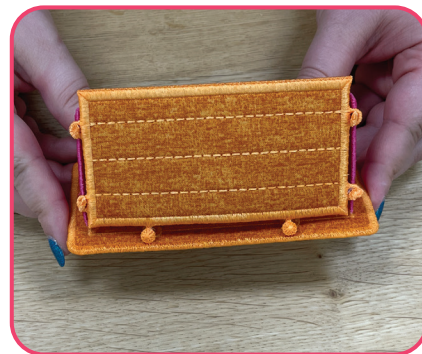
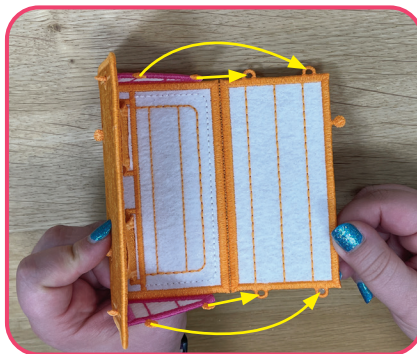

## Step 82

- Match the buttonettes on the bottom of the Business Card Holder Walls to the eyelets on the Business Card Holder Base & Shelf.
- Pull the buttonettes through the corresponding eyelets.

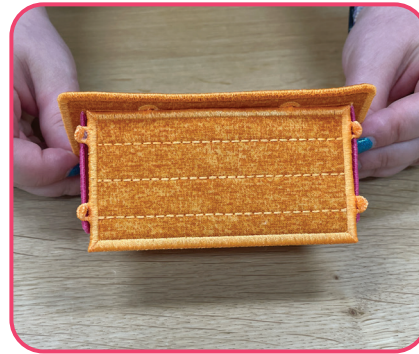
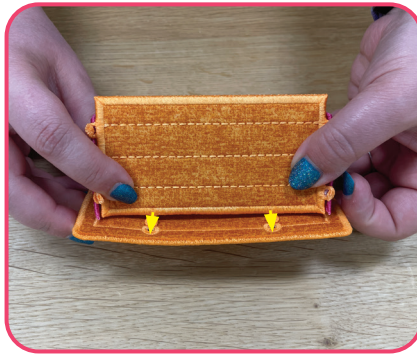

## Step 81

- The Business Card Holder is complete. Enjoy!

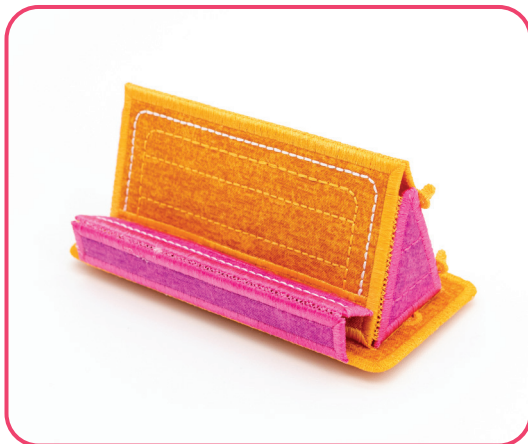

# PUNCH TOOL GUIDE

13043-02

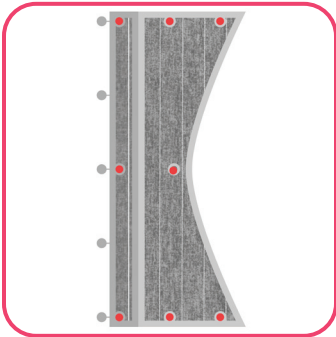

13043-03

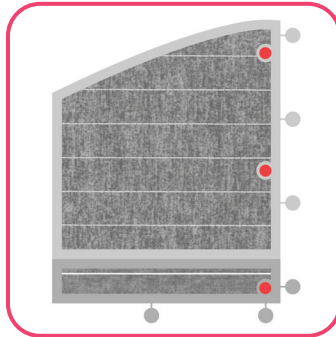

13043-06

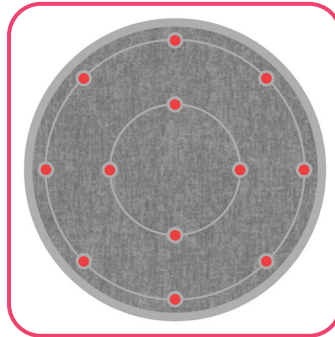

13043-07

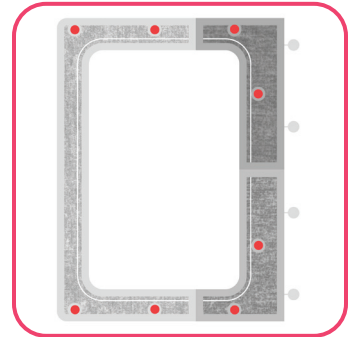

13043-11

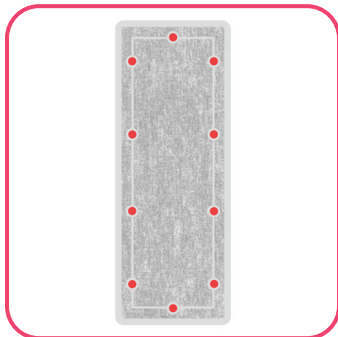

13043-12

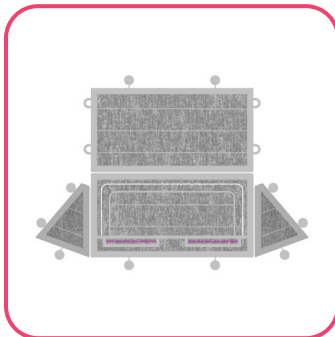

13043-13



= 2 MM

= 3 MM

= 4 MM

CRAFT KNIFE



## ATTENTION

When printing this document, any page scaling or page fitting options in your print dialog box must be turned OFF or set to NONE so that your files will print out at their actual size. Images not printed at actual size will not function as intended.

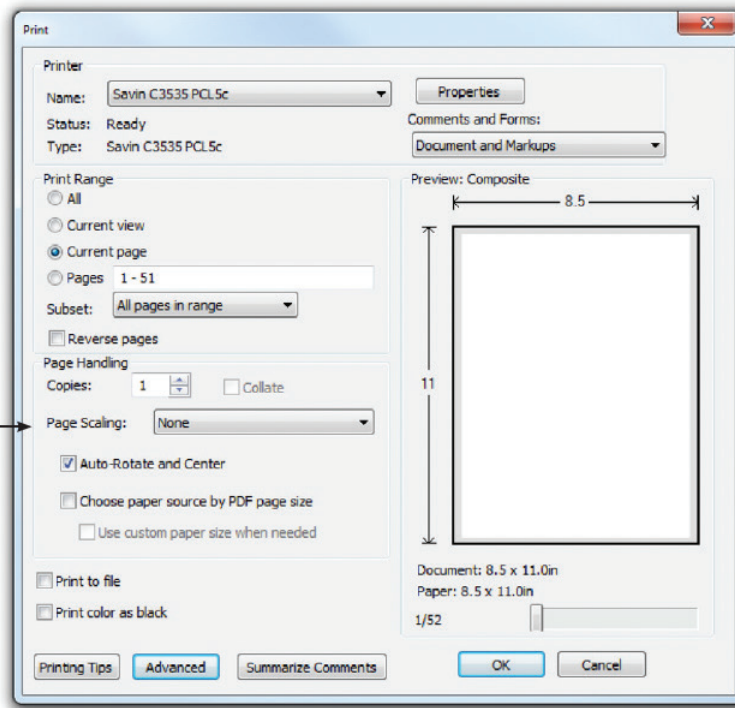

## TO SAVE PAPER

Only print the desired image by navigating to the image's page, go to File > Print and select "Current page" in the print dialog box. Repeat for each desired image.

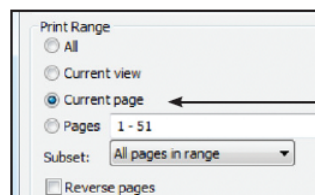

# APPLIQUE PATTERNS



Print at 100%. No scaling. This box measures 1" x 1". Use the box as an accuracy guide when printing templates.

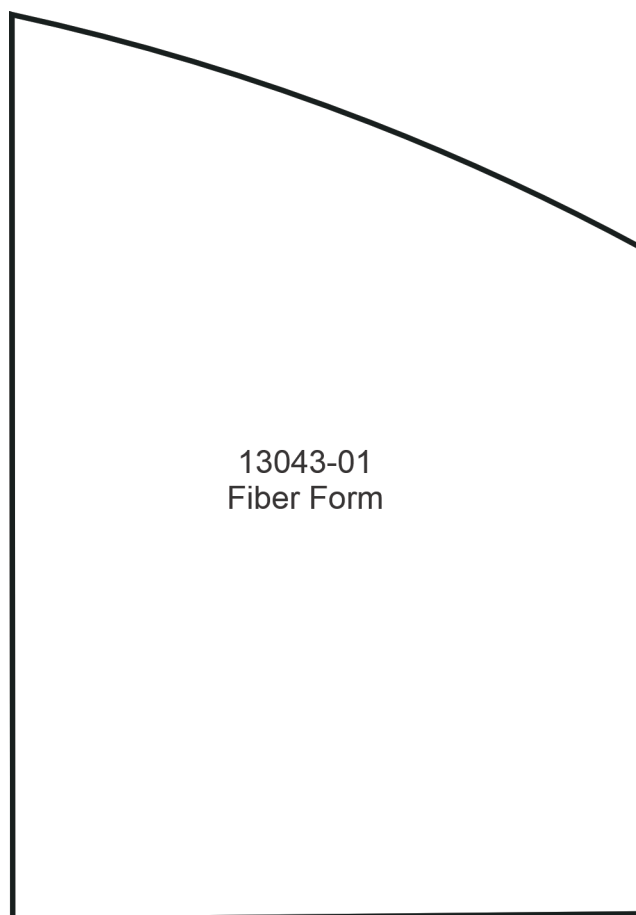

13043-01  
Fiber Form

# APPLIQUE PATTERNS



Print at 100%. No scaling. This box measures 1" x 1". Use the box as an accuracy guide when printing templates.

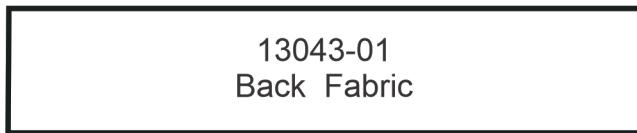
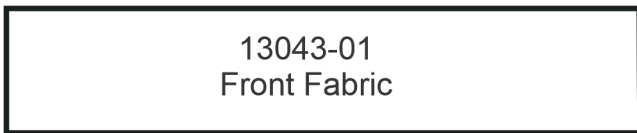
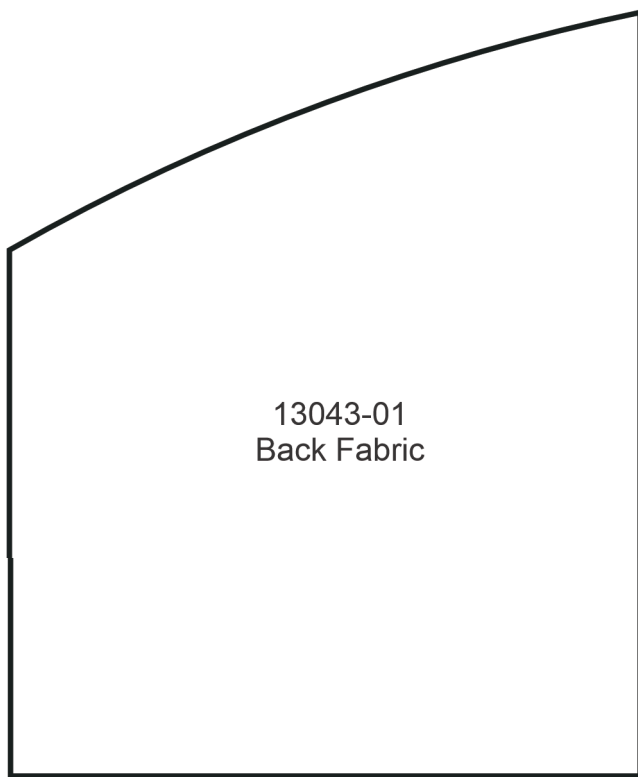
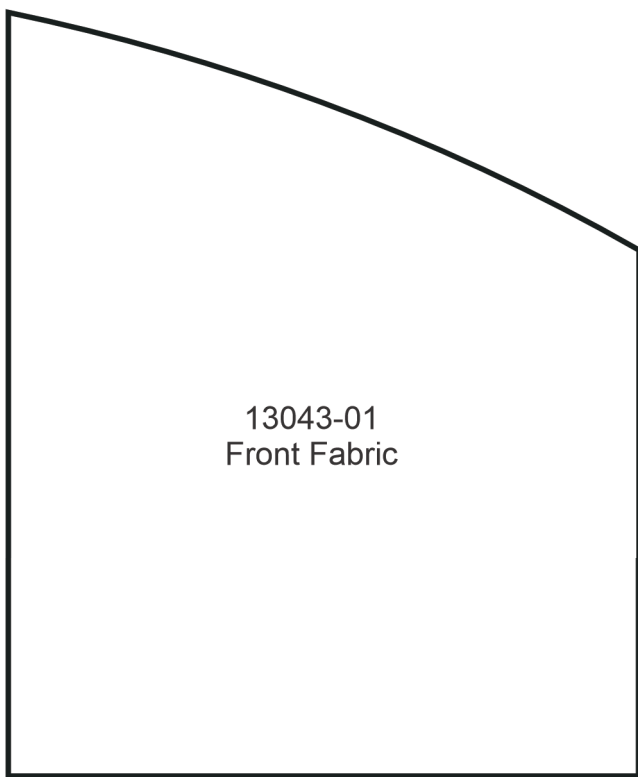

# APPLIQUE PATTERNS



Print at 100%. No scaling. This box measures 1" x 1". Use the box as an accuracy guide when printing templates.

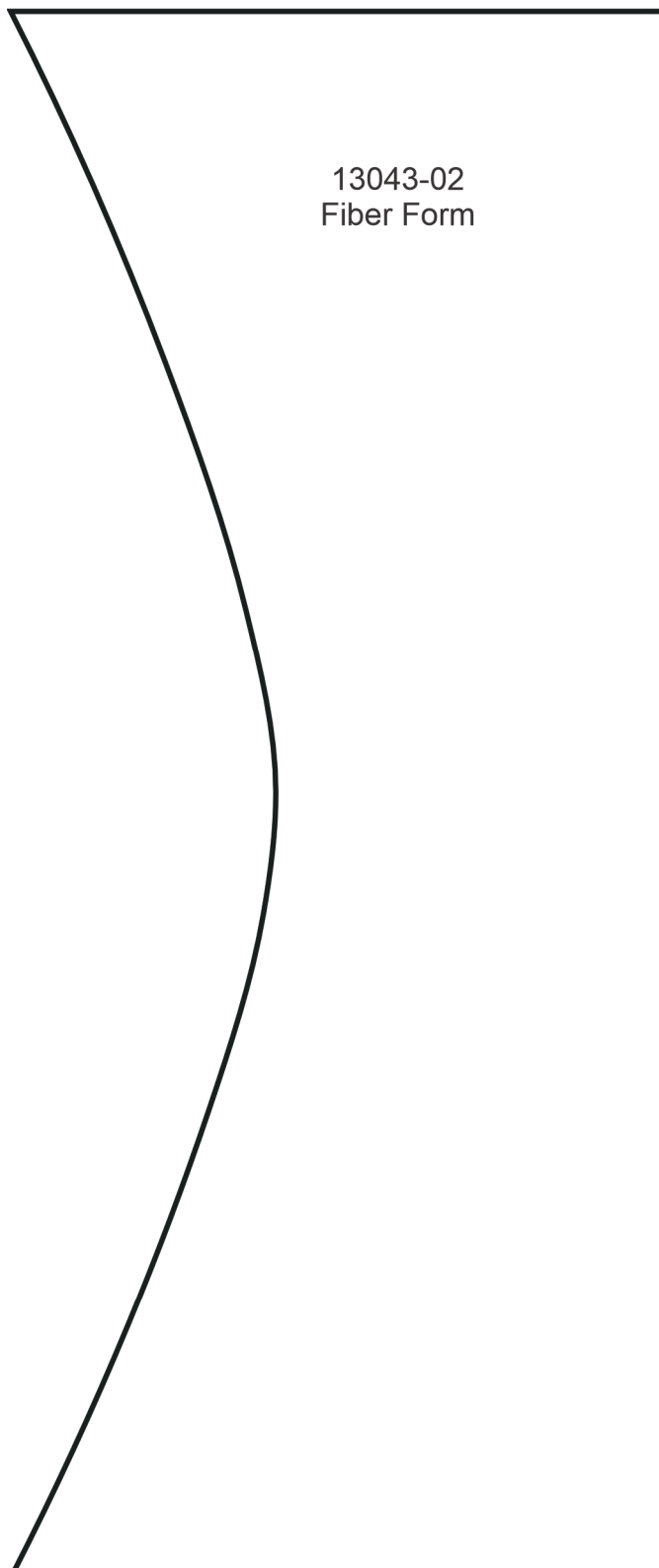

# APPLIQUE PATTERNS



Print at 100%. No scaling. This box measures 1" x 1". Use the box as an accuracy guide when printing templates.

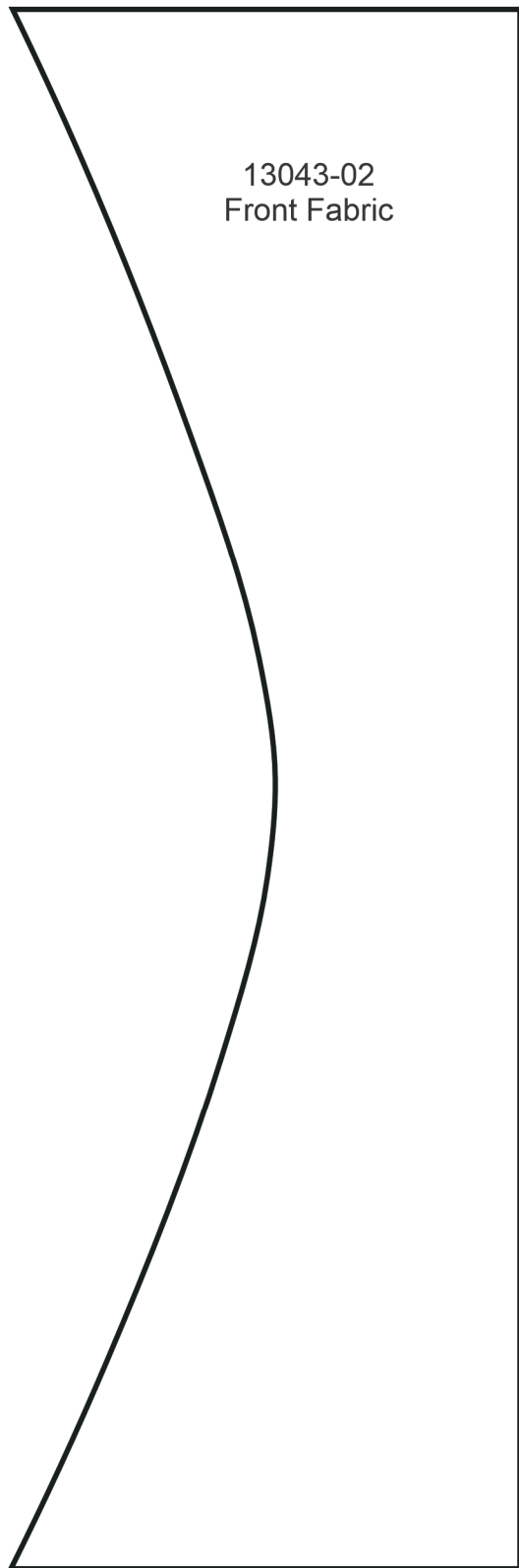

# APPLIQUE PATTERNS



Print at 100%. No scaling. This box measures 1" x 1". Use the box as an accuracy guide when printing templates.

13043-02  
Back Fabric

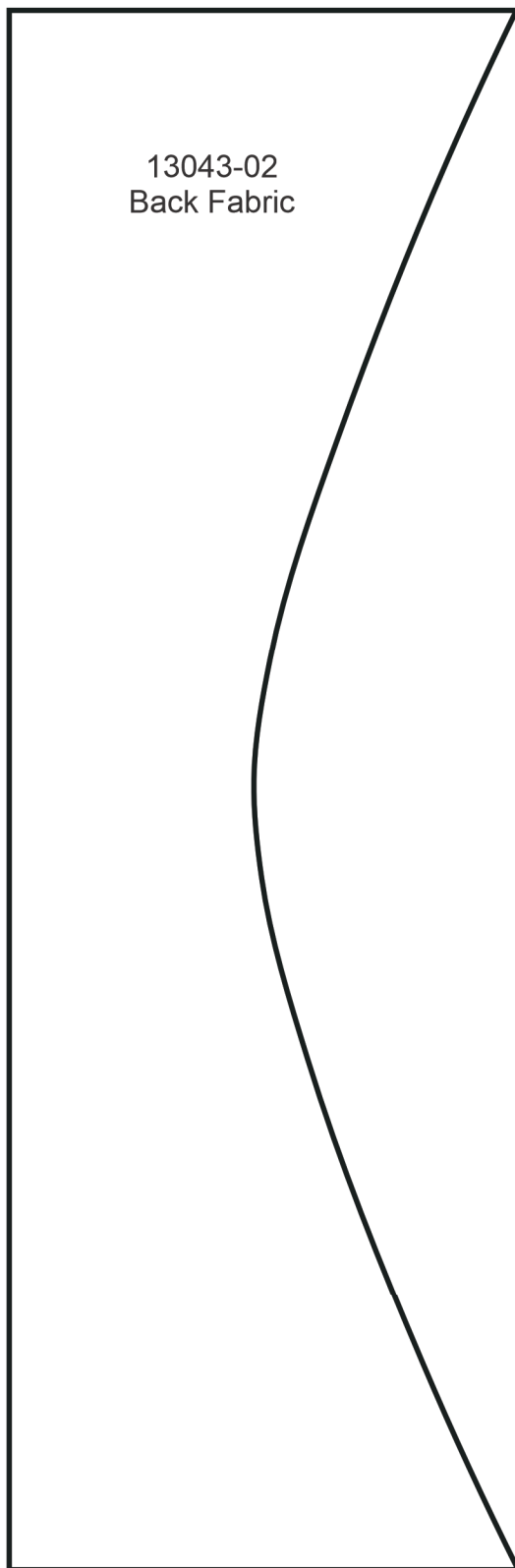

# APPLIQUE PATTERNS



Print at 100%. No scaling. This box measures 1" x 1". Use the box as an accuracy guide when printing templates.

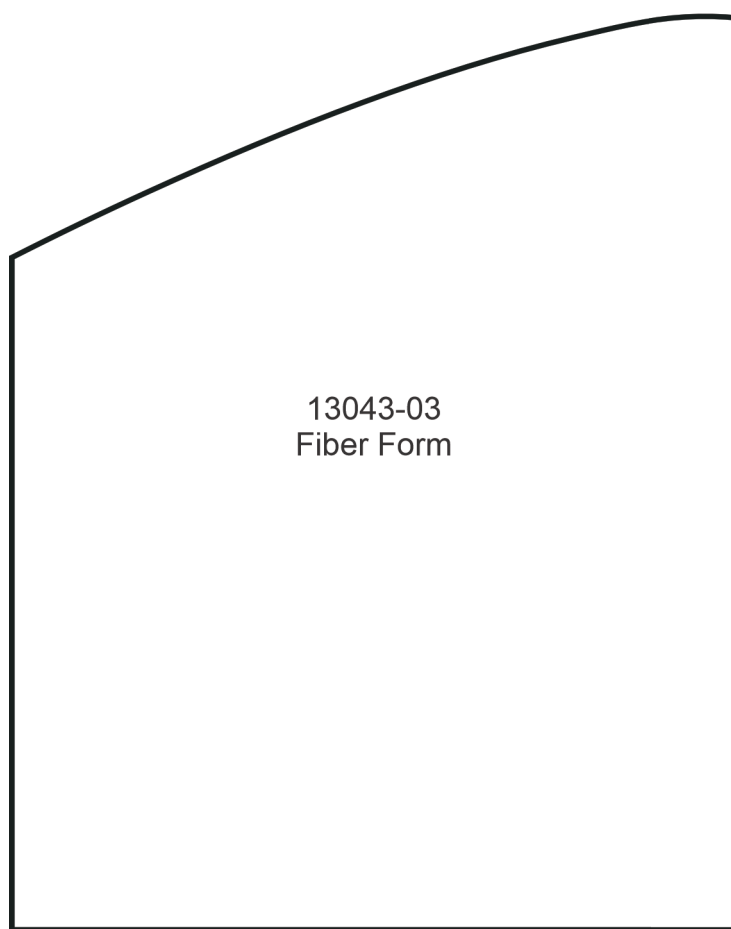

13043-03  
Fiber Form

# APPLIQUE PATTERNS



Print at 100%. No scaling. This box measures 1" x 1". Use the box as an accuracy guide when printing templates.

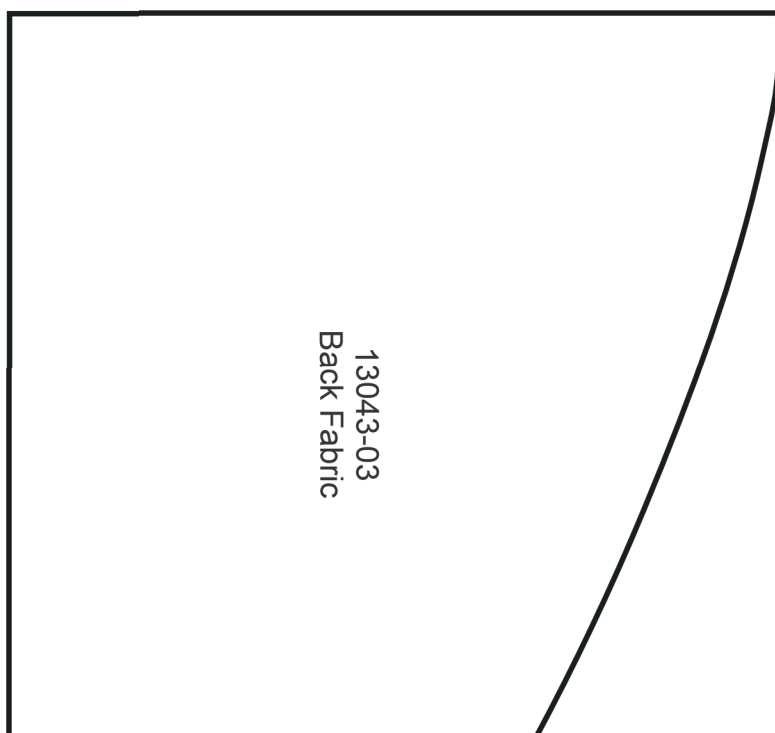
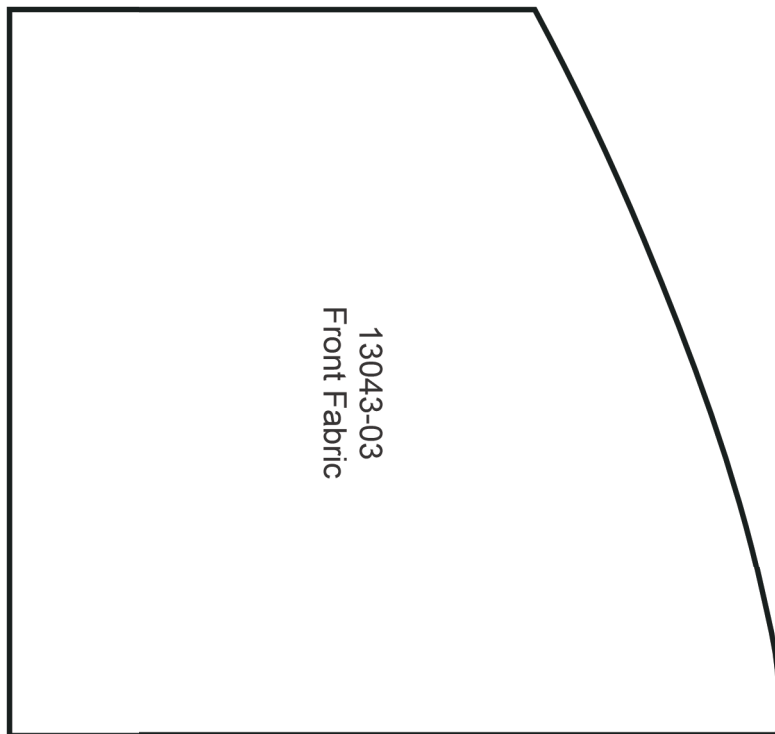

# APPLIQUE PATTERNS



Print at 100%. No scaling. This box measures 1" x 1". Use the box as an accuracy guide when printing templates.

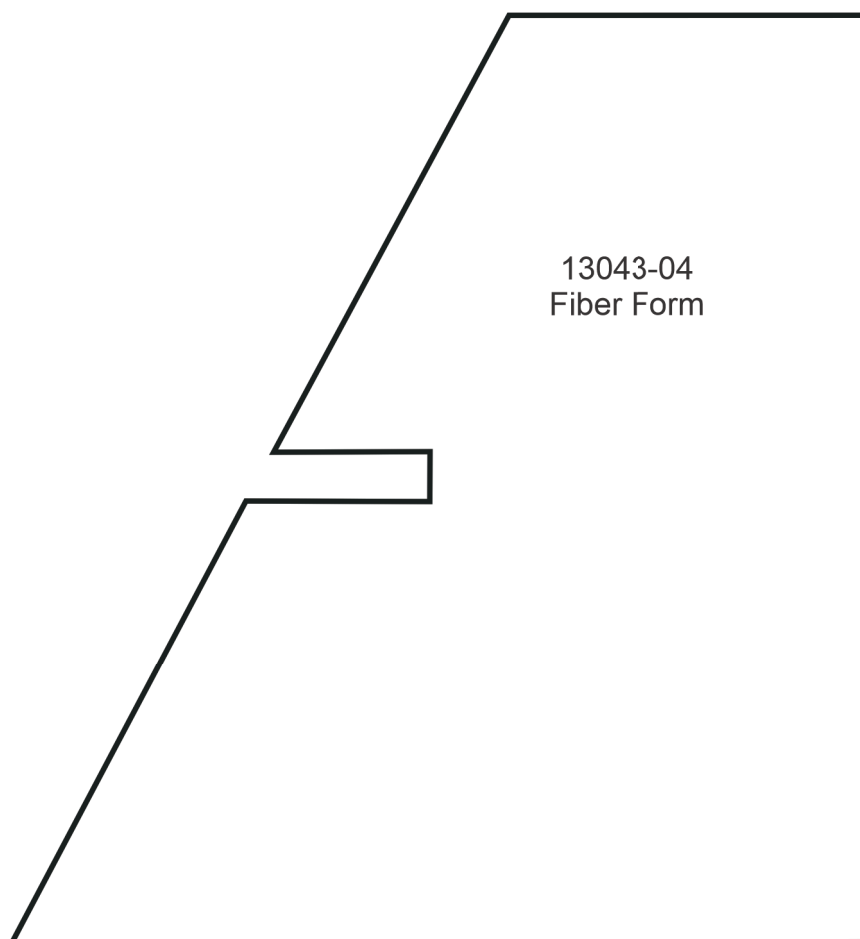

# APPLIQUE PATTERNS



Print at 100%. No scaling. This box measures 1" x 1". Use the box as an accuracy guide when printing templates.

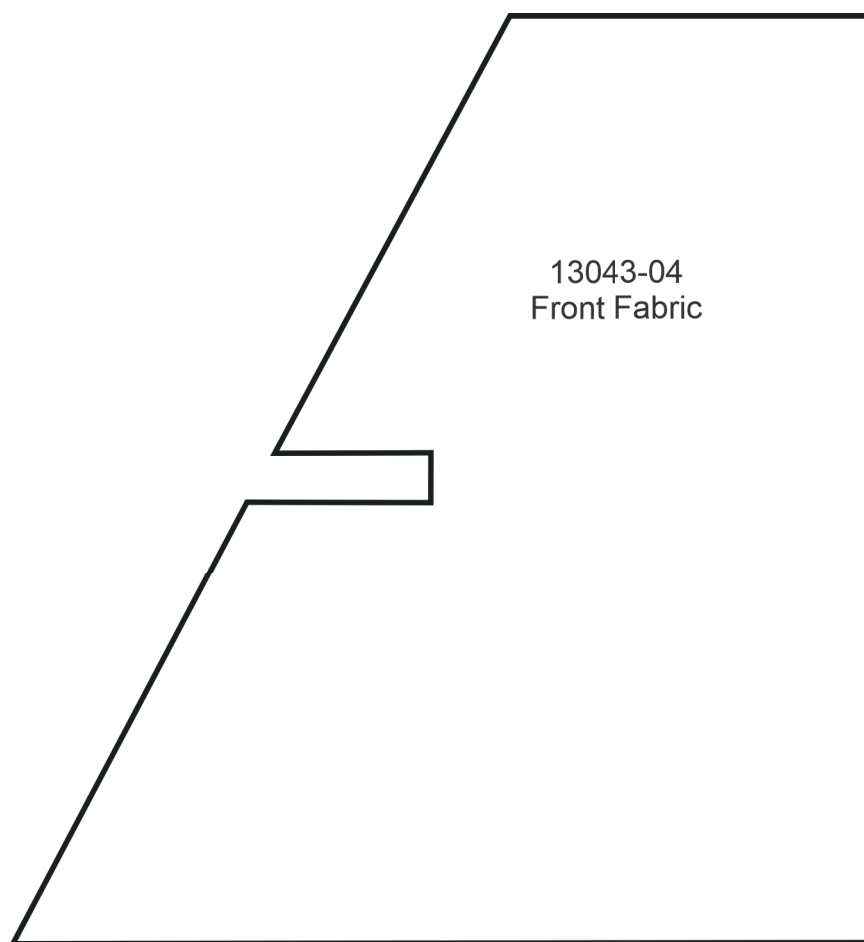

# APPLIQUE PATTERNS



Print at 100%. No scaling. This box measures 1" x 1". Use the box as an accuracy guide when printing templates.

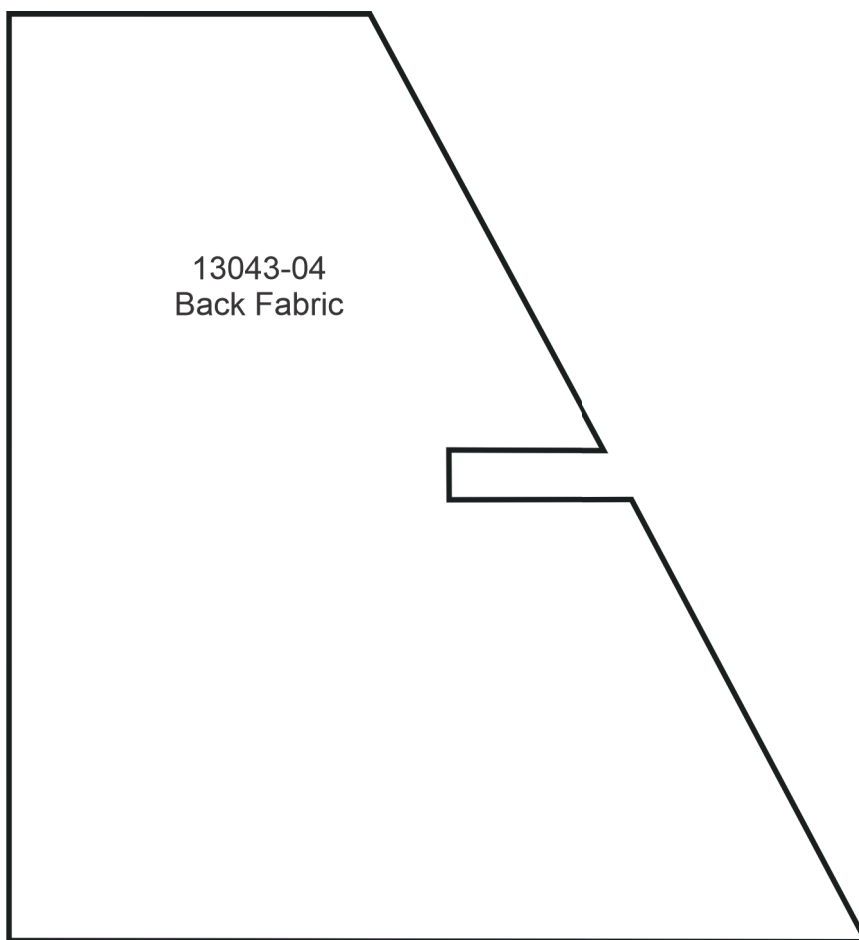

# APPLIQUE PATTERNS



Print at 100%. No scaling. This box measures 1" x 1". Use the box as an accuracy guide when printing templates.

13043-05  
Fiber Form

13043-05  
Front Fabric

# APPLIQUE PATTERNS



Print at 100%. No scaling. This box measures 1" x 1". Use the box as an accuracy guide when printing templates.

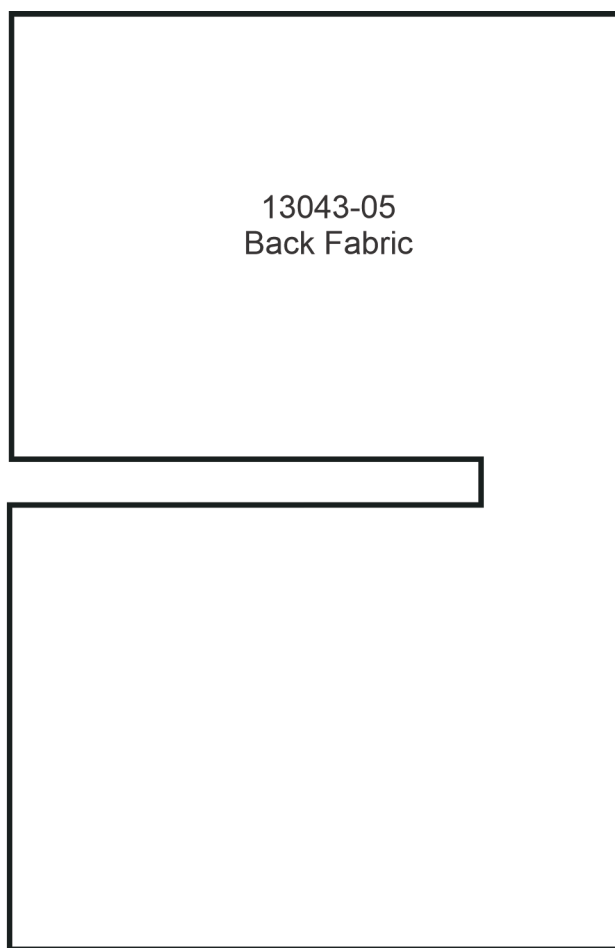

13043-05  
Back Fabric

# APPLIQUE PATTERNS



Print at 100%. No scaling. This box measures 1" x 1". Use the box as an accuracy guide when printing templates.

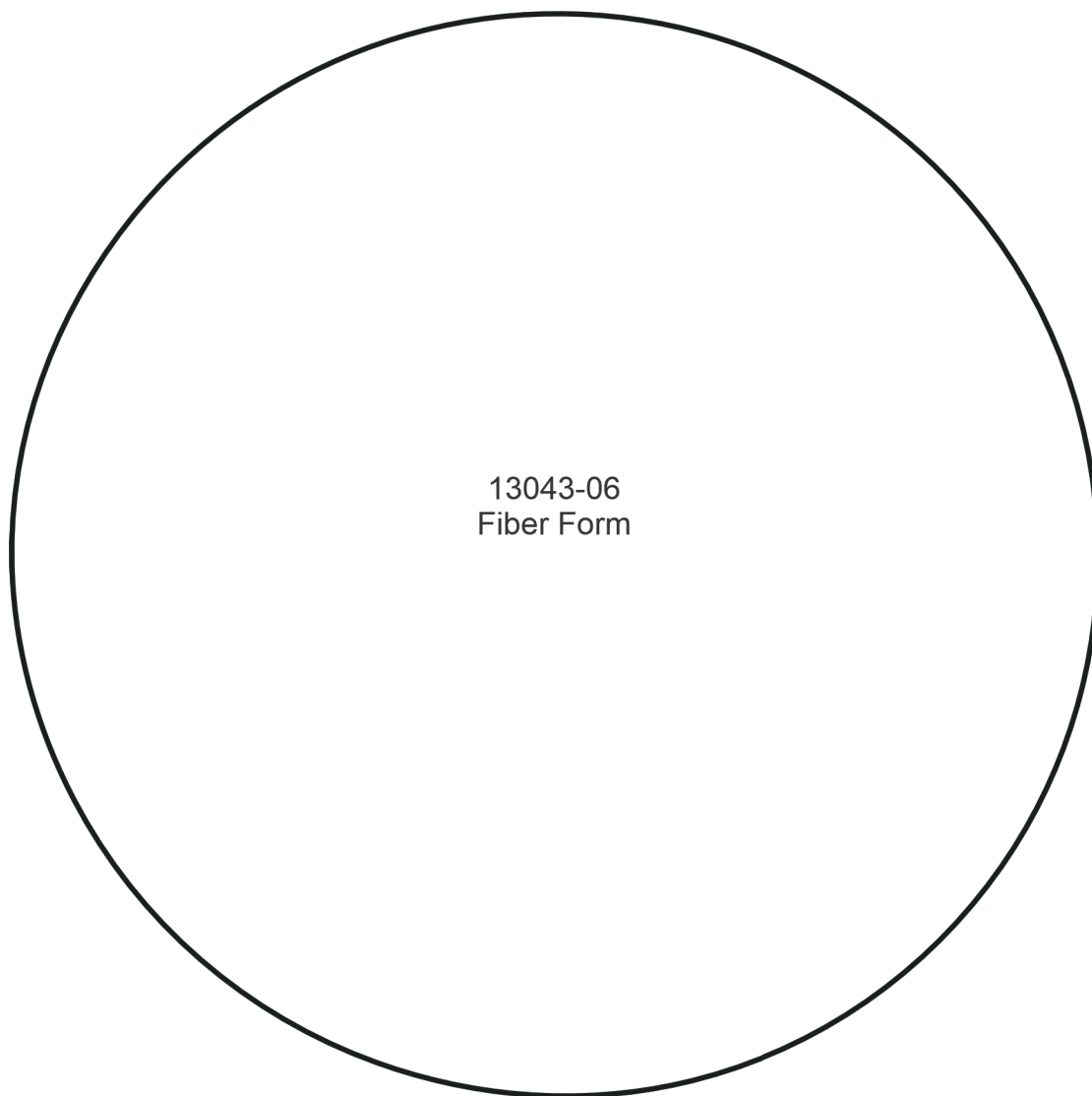

13043-06  
Fiber Form

# APPLIQUE PATTERNS



Print at 100%. No scaling. This box measures 1" x 1". Use the box as an accuracy guide when printing templates.

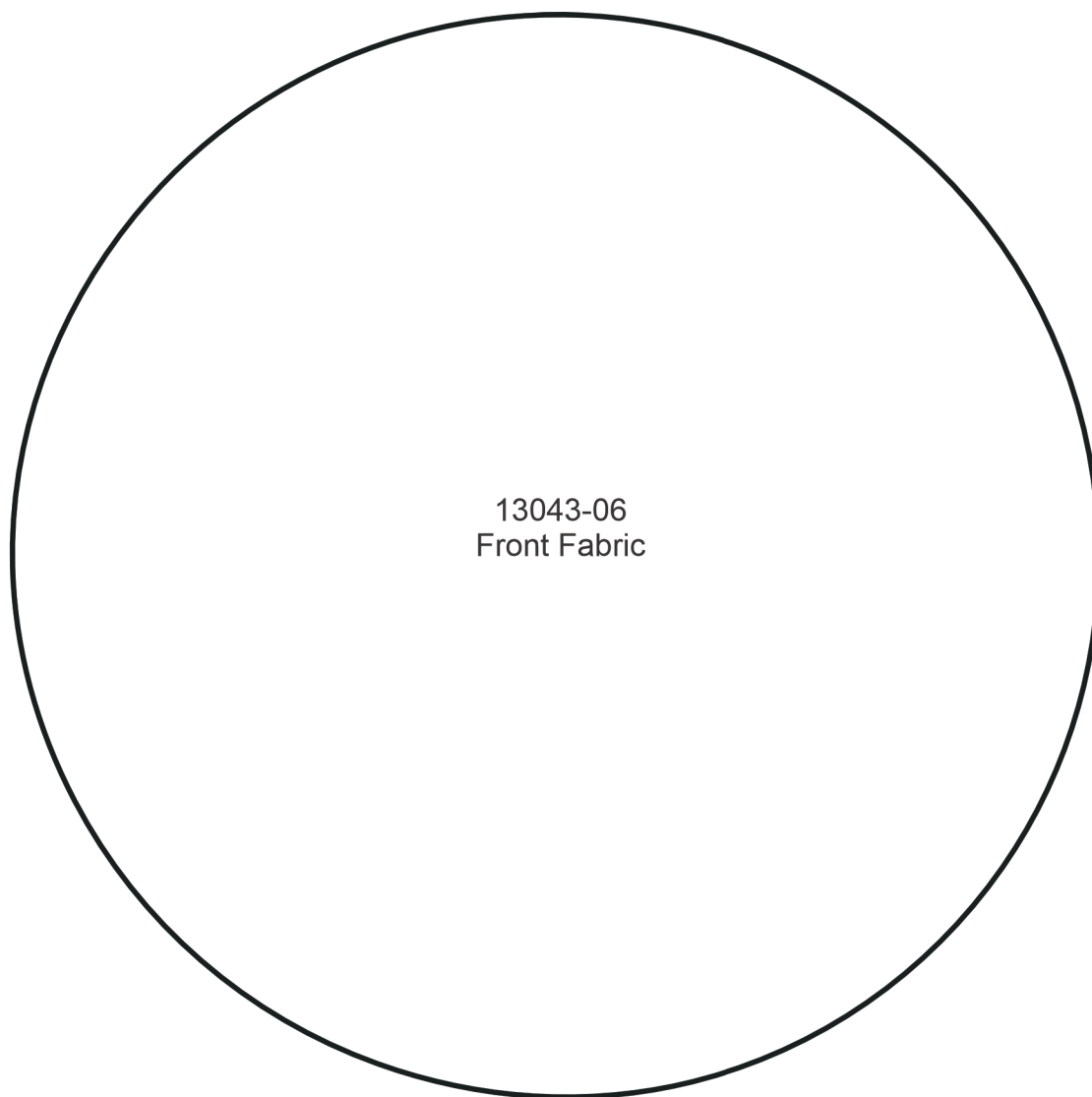

13043-06  
Front Fabric

# APPLIQUE PATTERNS



Print at 100%. No scaling. This box measures 1" x 1". Use the box as an accuracy guide when printing templates.

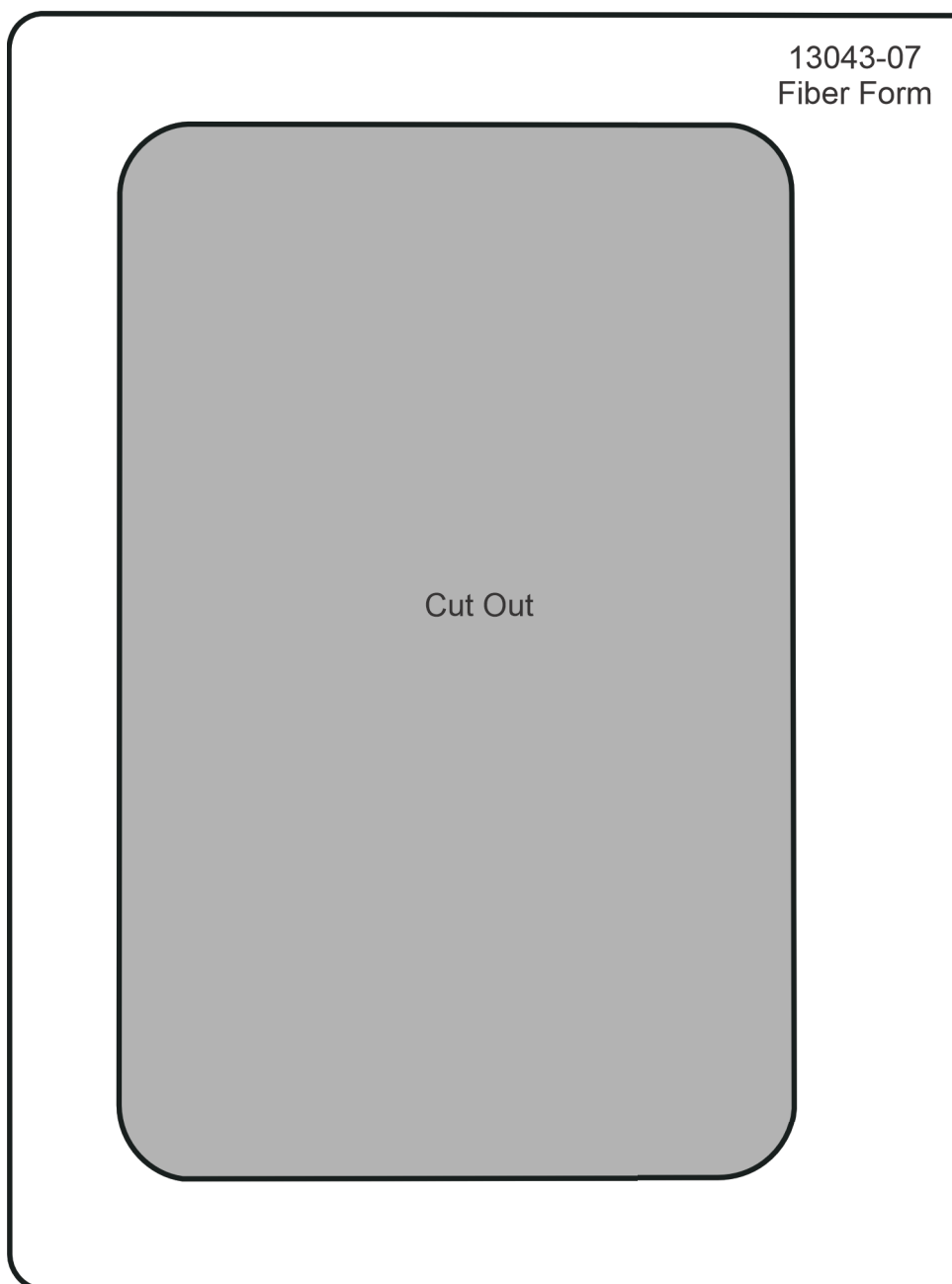

# APPLIQUE PATTERNS



Print at 100%. No scaling. This box measures 1" x 1". Use the box as an accuracy guide when printing templates.

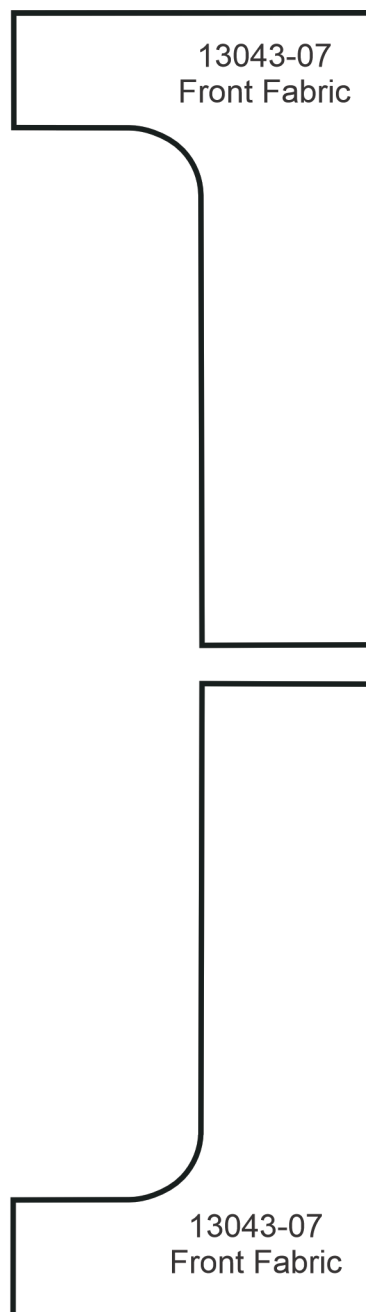

# APPLIQUE PATTERNS



Print at 100%. No scaling. This box measures 1" x 1". Use the box as an accuracy guide when printing templates.

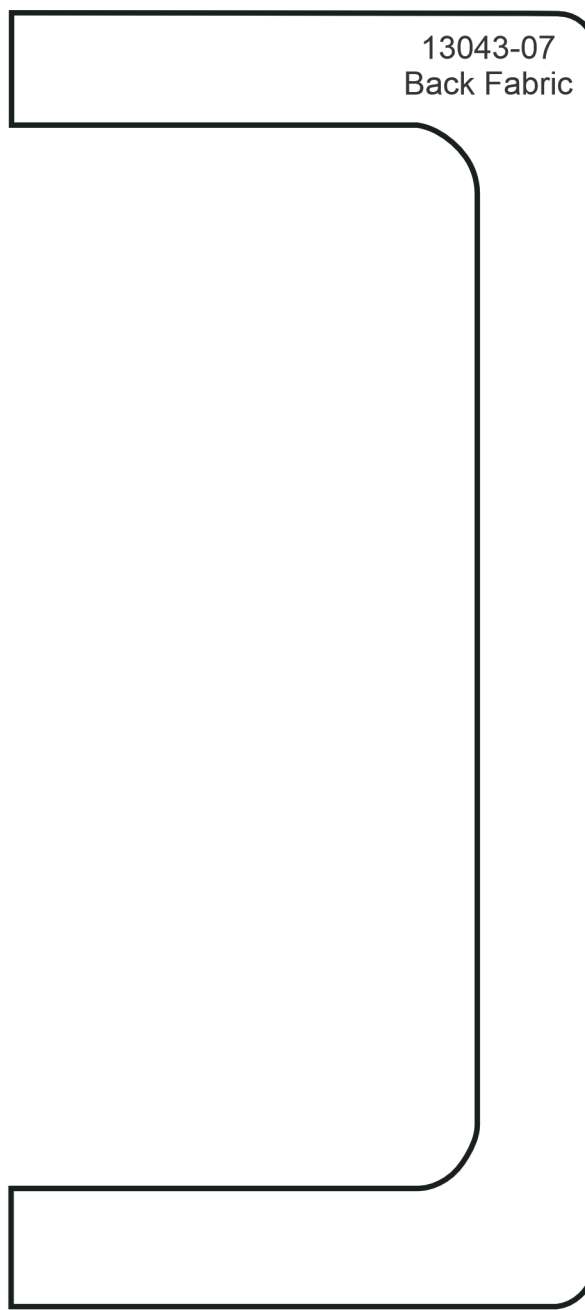
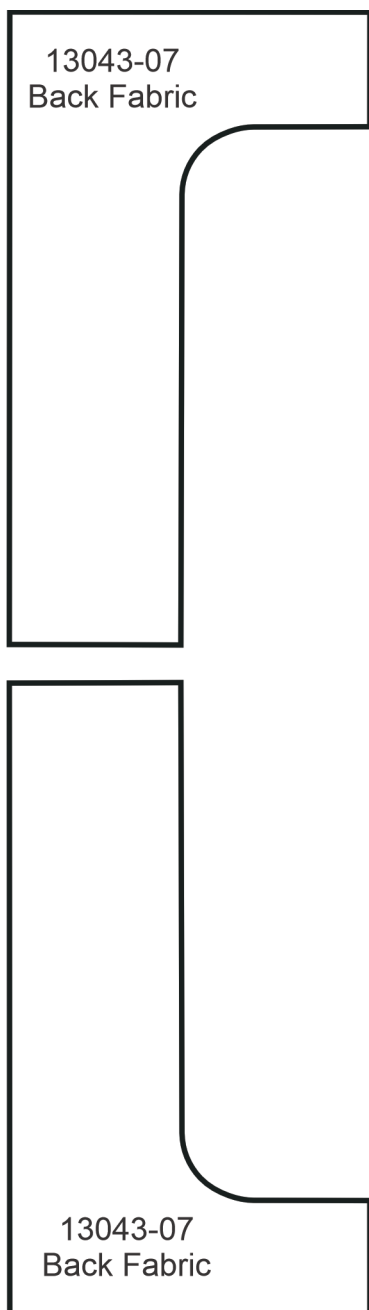

# APPLIQUE PATTERNS



Print at 100%. No scaling. This box measures 1" x 1". Use the box as an accuracy guide when printing templates.

13043-07  
Clear Vinyl

# APPLIQUE PATTERNS



Print at 100%. No scaling. This box measures 1" x 1". Use the box as an accuracy guide when printing templates.

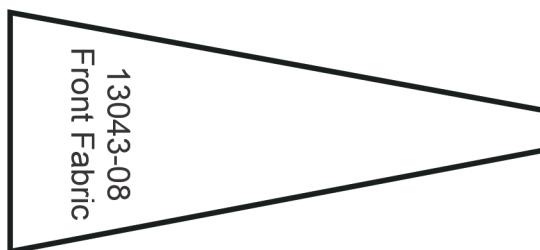
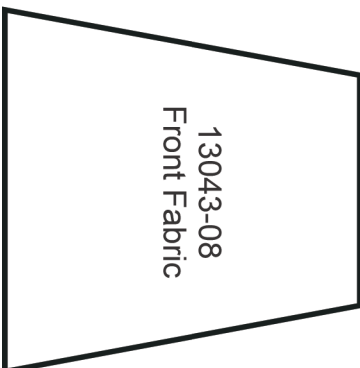
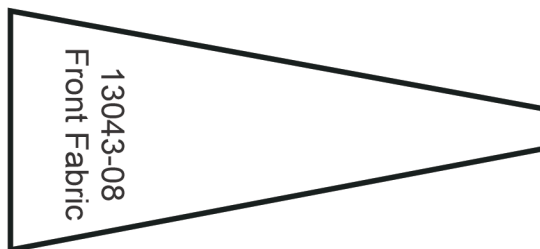
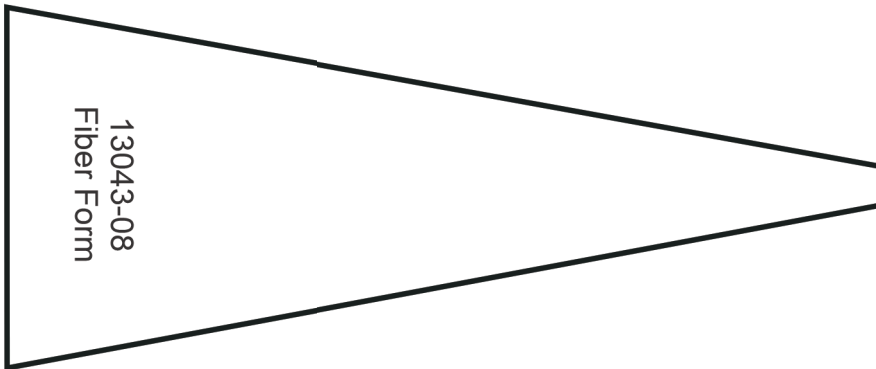
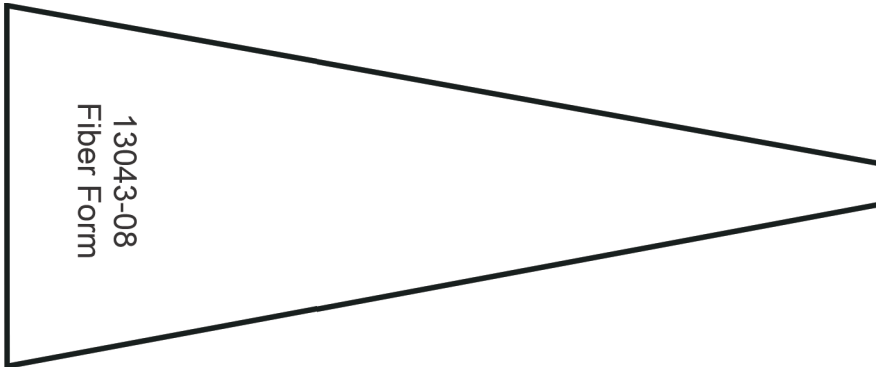

# APPLIQUE PATTERNS



Print at 100%. No scaling. This box measures 1" x 1". Use the box as an accuracy guide when printing templates.

13043-09  
Fiber Form

# APPLIQUE PATTERNS



Print at 100%. No scaling. This box measures 1" x 1". Use the box as an accuracy guide when printing templates.

13043-09  
Front Fabric

# APPLIQUE PATTERNS



Print at 100%. No scaling. This box measures 1" x 1". Use the box as an accuracy guide when printing templates.

13043-09  
Back Fabric

# APPLIQUE PATTERNS



Print at 100%. No scaling. This box measures 1" x 1". Use the box as an accuracy guide when printing templates.

13043-10  
Fiber Form

# APPLIQUE PATTERNS



Print at 100%. No scaling. This box measures 1" x 1". Use the box as an accuracy guide when printing templates.

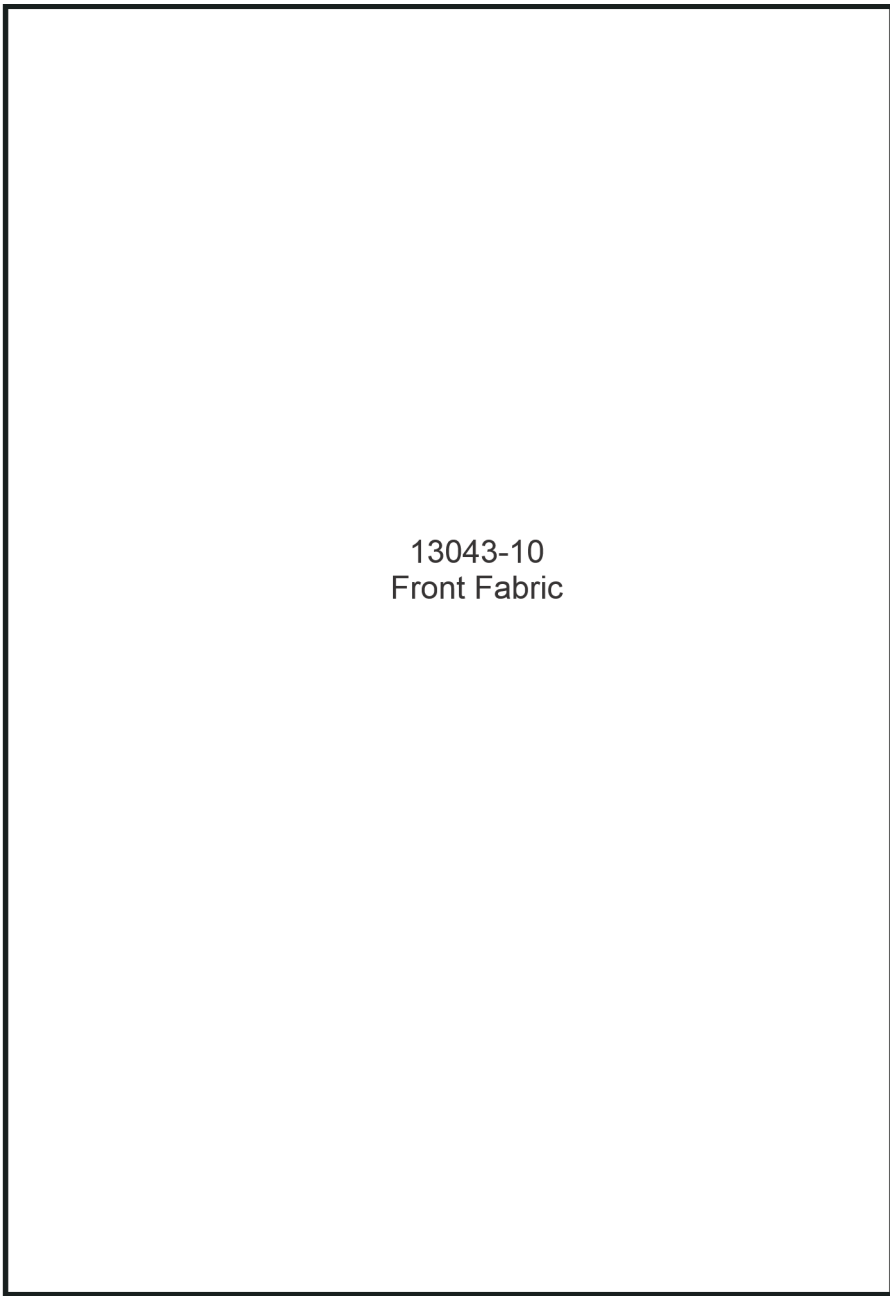

13043-10  
Front Fabric

# APPLIQUE PATTERNS



Print at 100%. No scaling. This box measures 1" x 1". Use the box as an accuracy guide when printing templates.

13043-11  
Fiber Form

13043-11  
Front Fabric

# APPLIQUE PATTERNS

Print at 100%. No scaling. This box measures 1" x 1". Use the box as an accuracy guide when printing templates.

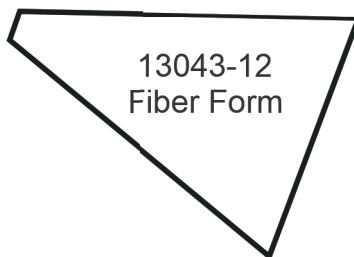
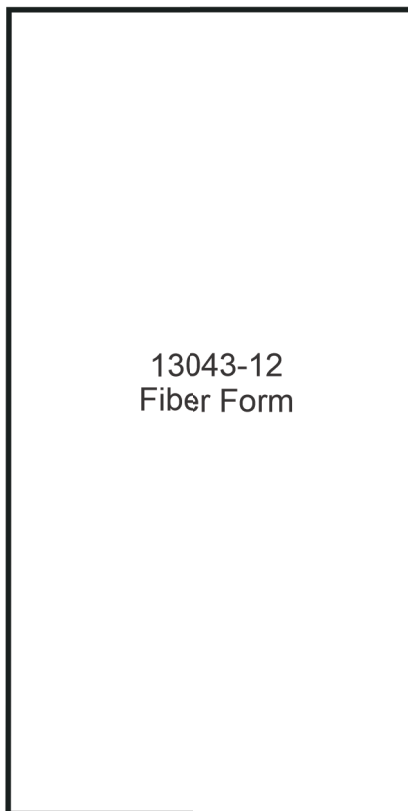
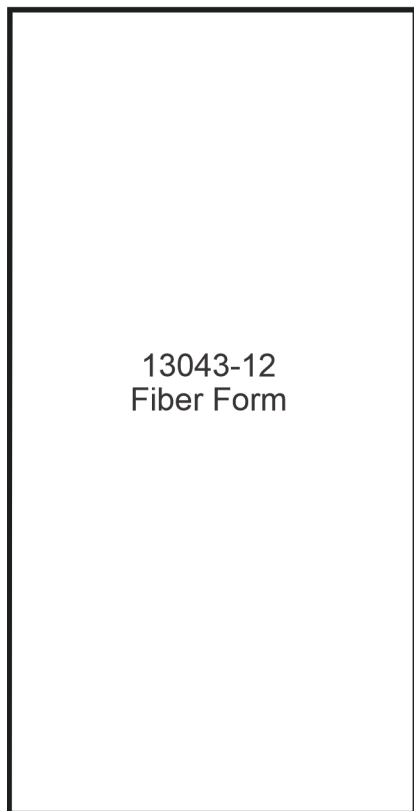
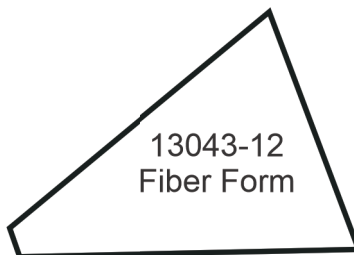

# APPLIQUE PATTERNS

Print at 100%. No scaling. This box measures 1" x 1". Use the box as an accuracy guide when printing templates.

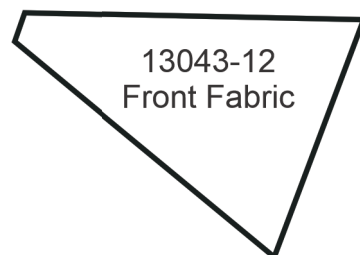
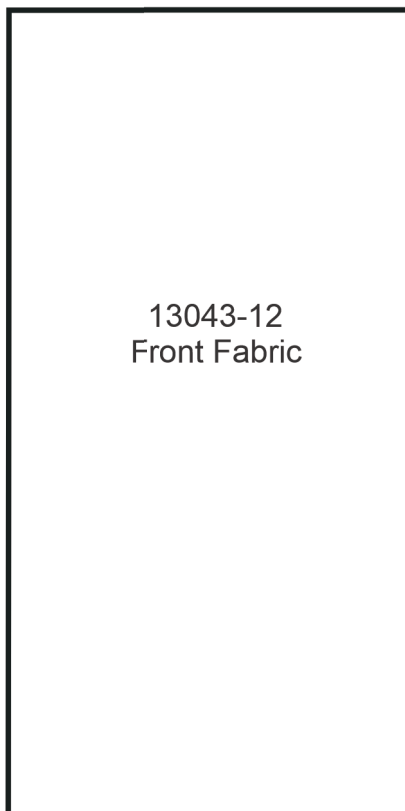
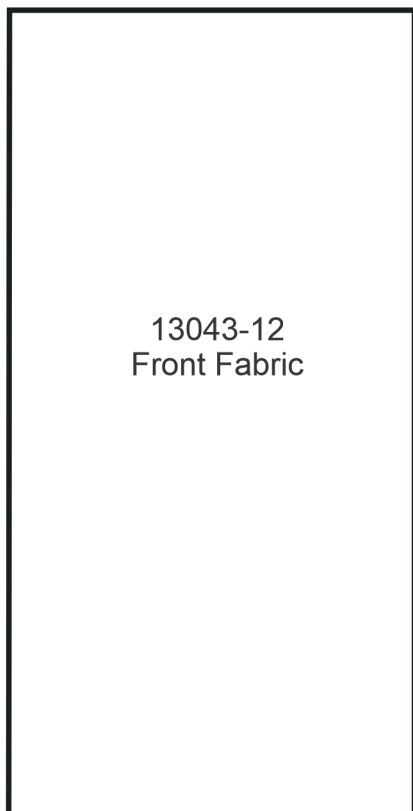
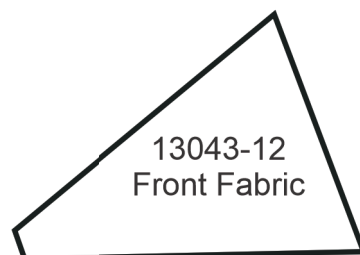

# APPLIQUE PATTERNS



Print at 100%. No scaling. This box measures 1" x 1". Use the box as an accuracy guide when printing templates.

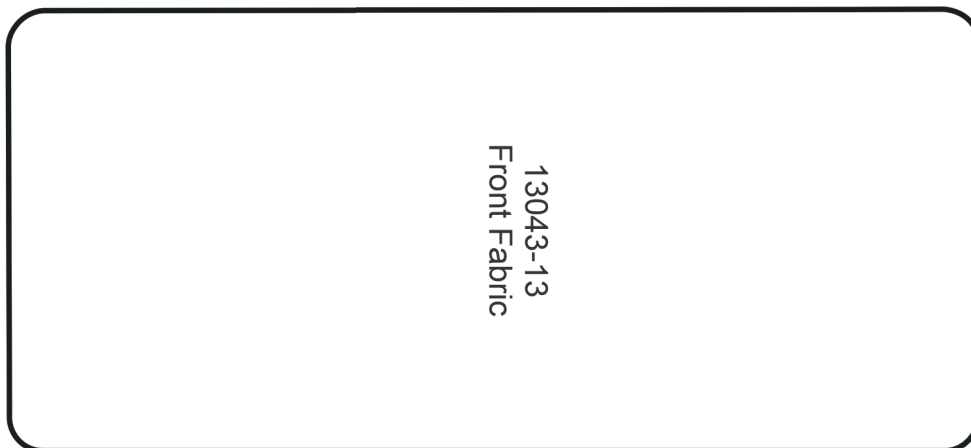
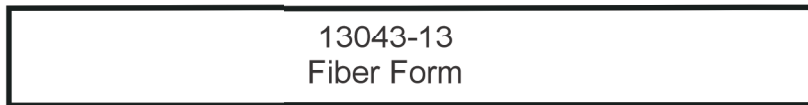
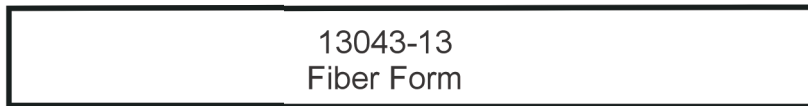
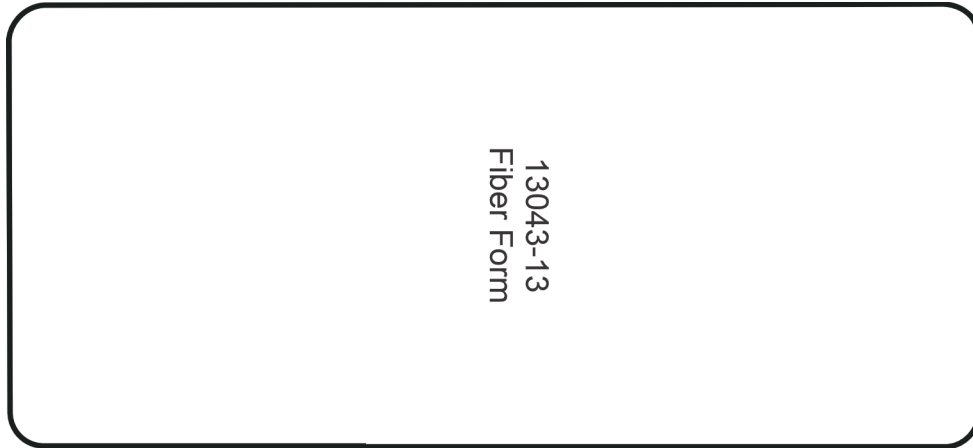

# APPLIQUE PATTERNS



Print at 100%. No scaling. This box measures 1" x 1". Use the box as an accuracy guide when printing templates.

13043-13  
Back Fabric

13043-13  
Back Fabric

13043-13  
Back Fabric

# MIRRORED PATTERNS



Print at 100%. No scaling. This box measures 1" x 1". Use the box as an accuracy guide when printing templates.

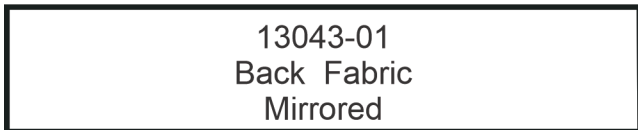
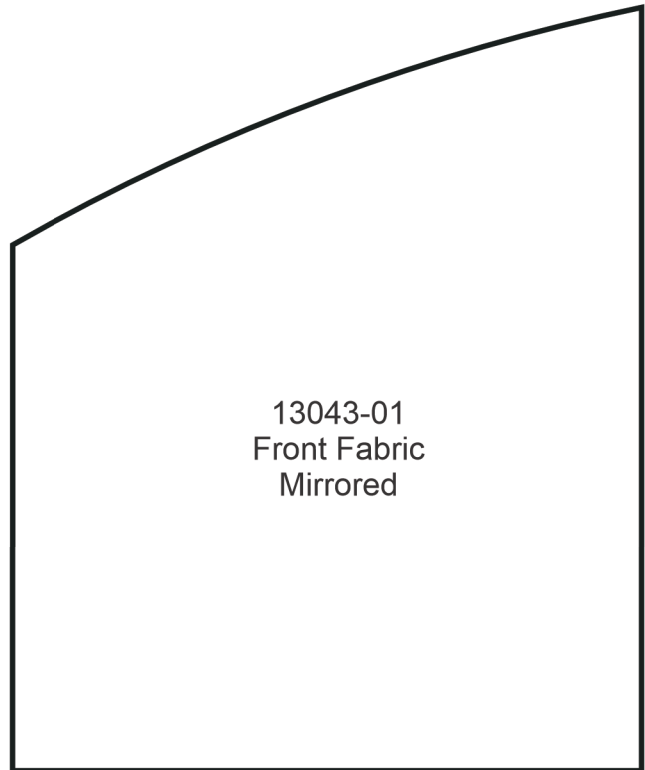
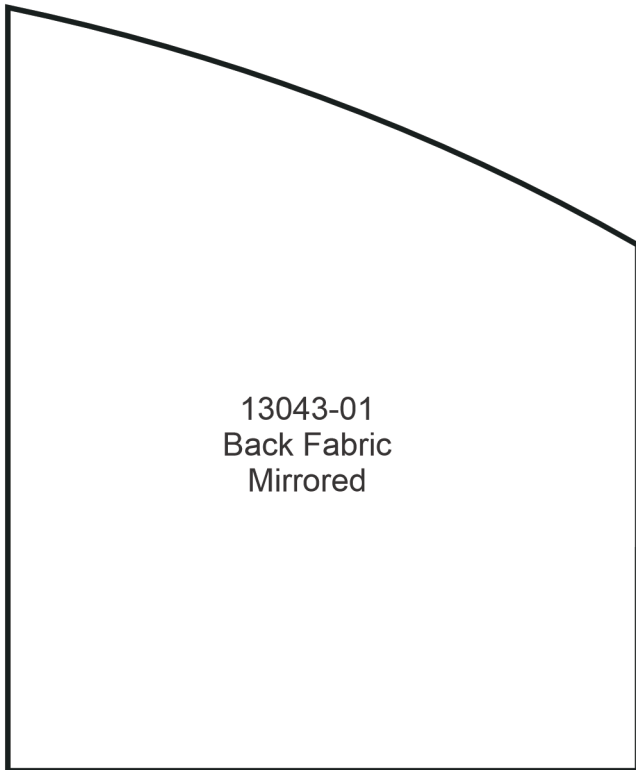

# MIRRORED PATTERNS



Print at 100%. No scaling. This box measures 1" x 1". Use the box as an accuracy guide when printing templates.

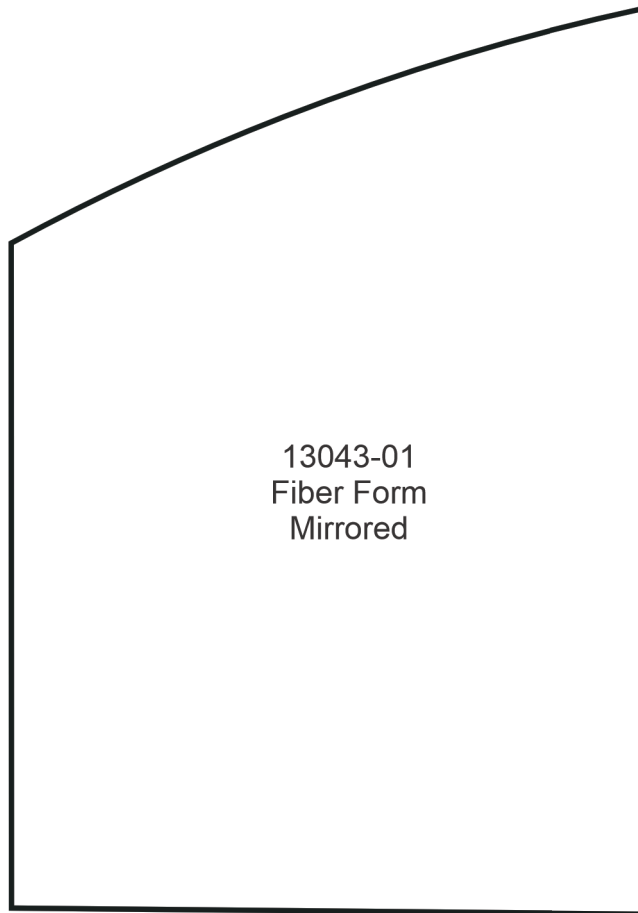

13043-01  
Fiber Form  
Mirrored

# MIRRORED PATTERNS



Print at 100%. No scaling. This box measures 1" x 1". Use the box as an accuracy guide when printing templates.

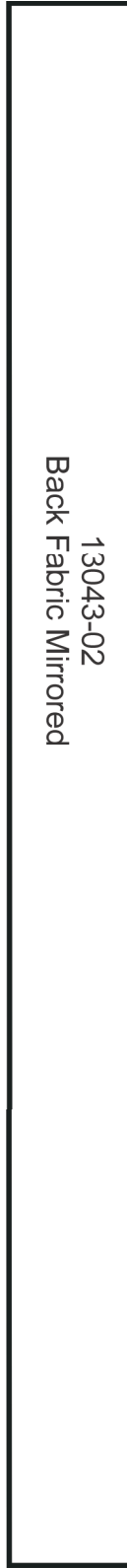
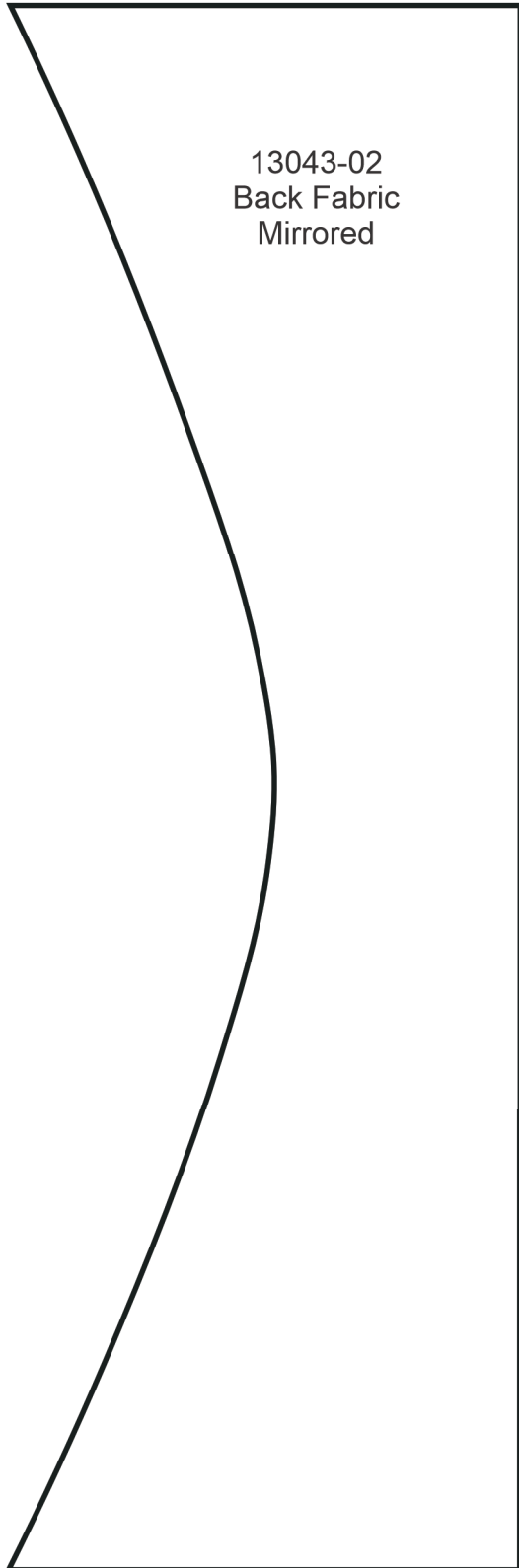

# MIRRORED PATTERNS



Print at 100%. No scaling. This box measures 1" x 1". Use the box as an accuracy guide when printing templates.

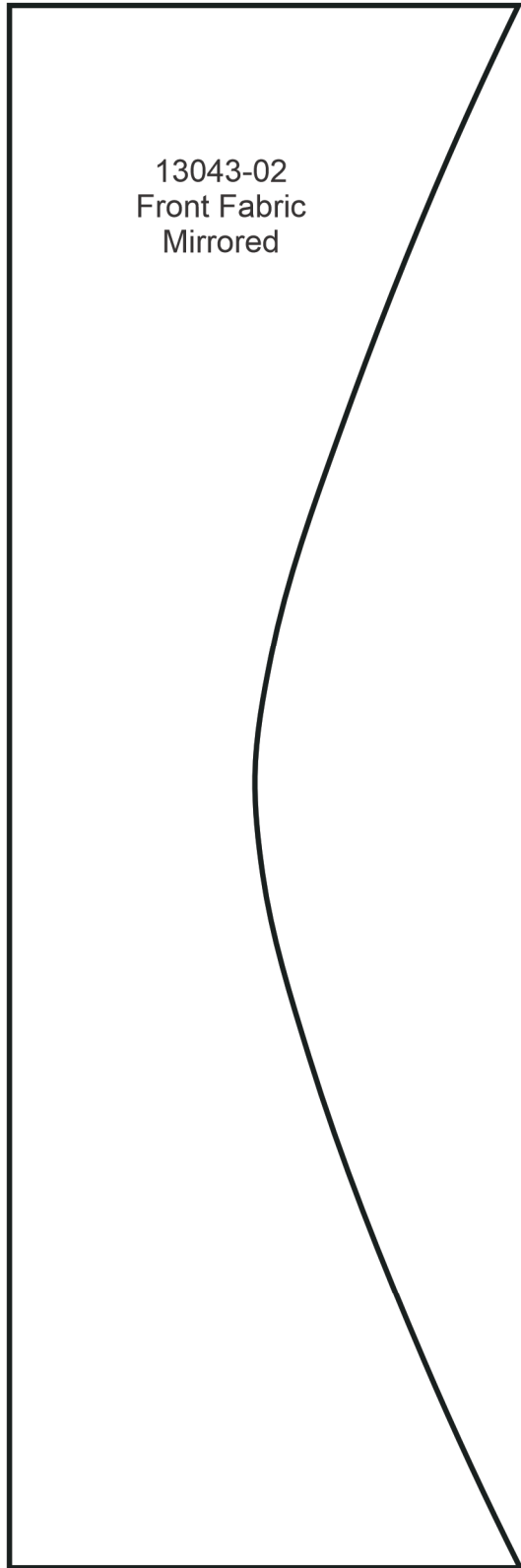

# MIRRORED PATTERNS



Print at 100%. No scaling. This box measures 1" x 1". Use the box as an accuracy guide when printing templates.

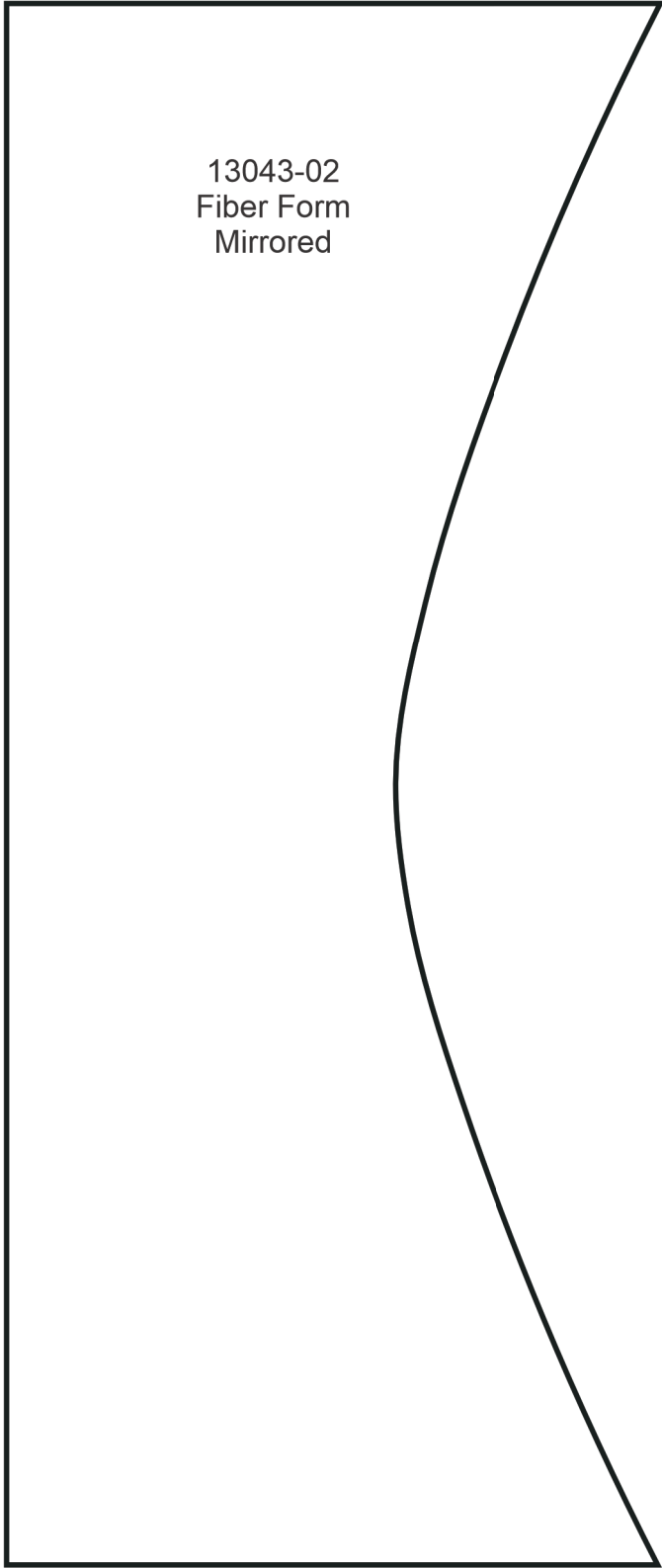

13043-02  
Fiber Form  
Mirrored

# MIRRORED PATTERNS



Print at 100%. No scaling. This box measures 1" x 1". Use the box as an accuracy guide when printing templates.

13043-03  
Back Fabric  
Mirrored

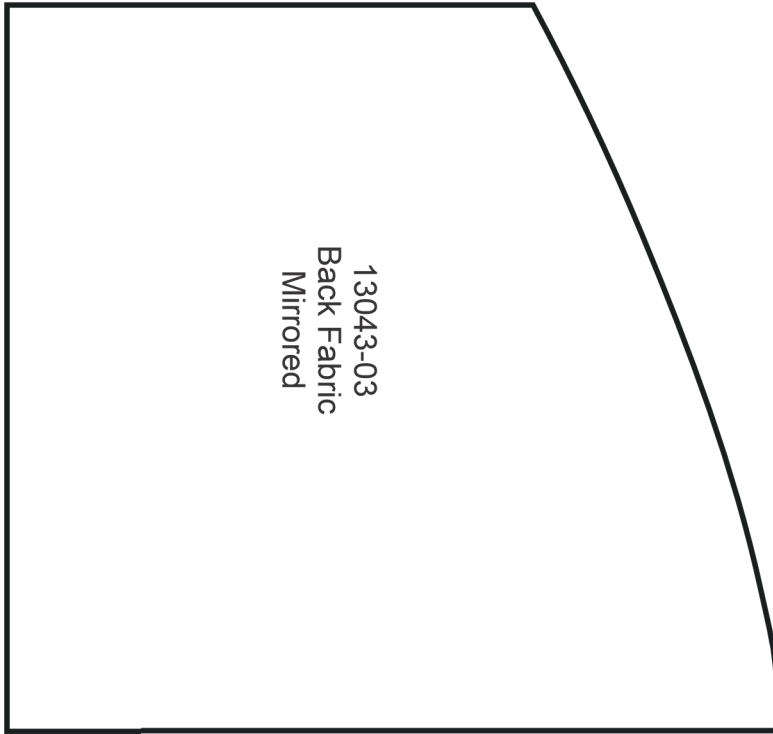

13043-03  
Back Fabric  
Mirrored

13043-03  
Front Fabric  
Mirrored

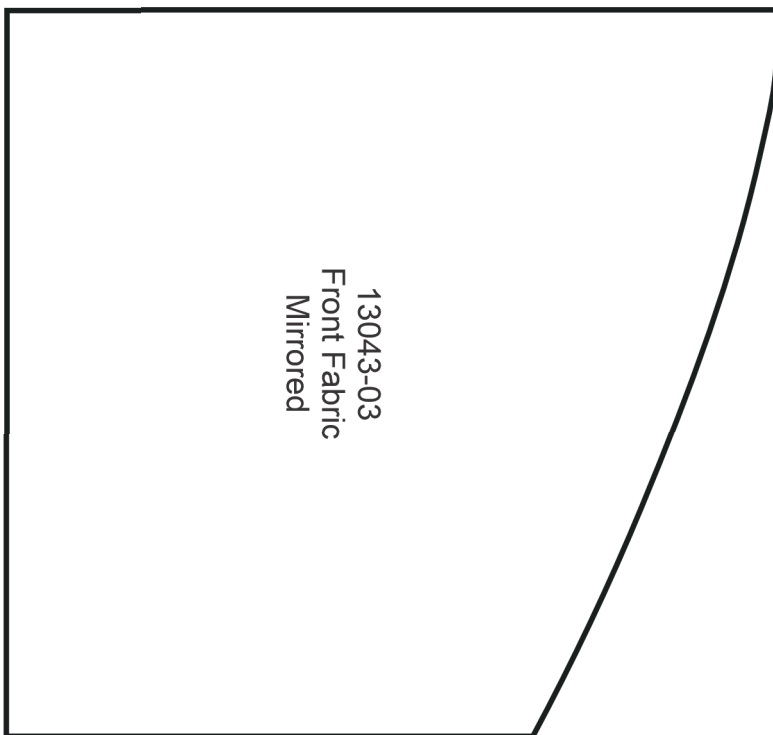

13043-03  
Front Fabric  
Mirrored

# MIRRORED PATTERNS



Print at 100%. No scaling. This box measures 1" x 1". Use the box as an accuracy guide when printing templates.

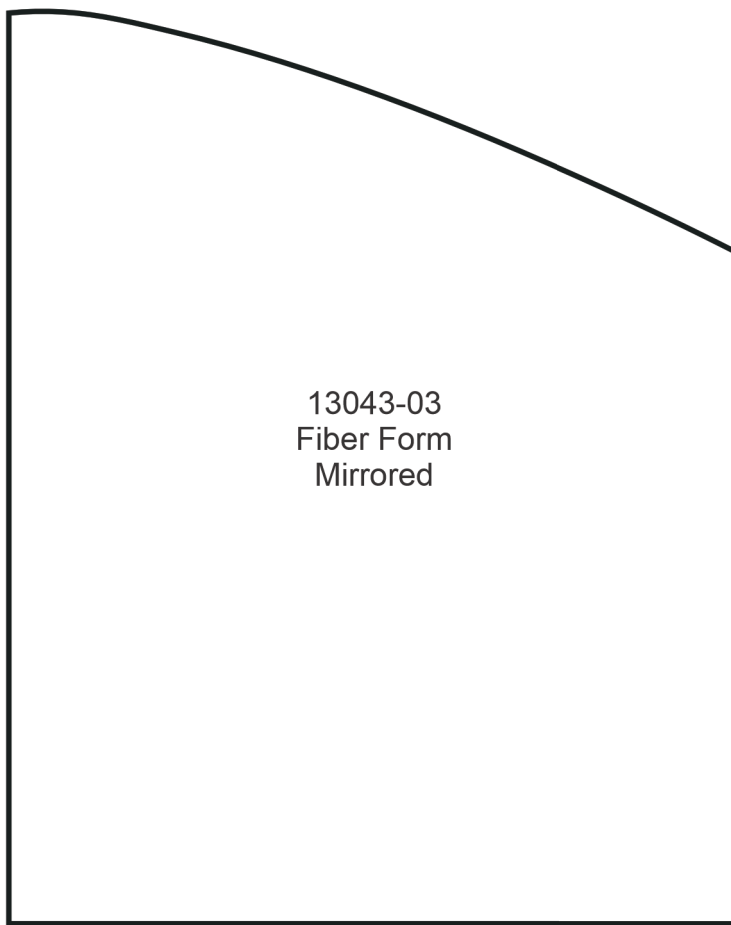

# MIRRORED PATTERNS



Print at 100%. No scaling. This box measures 1" x 1". Use the box as an accuracy guide when printing templates.

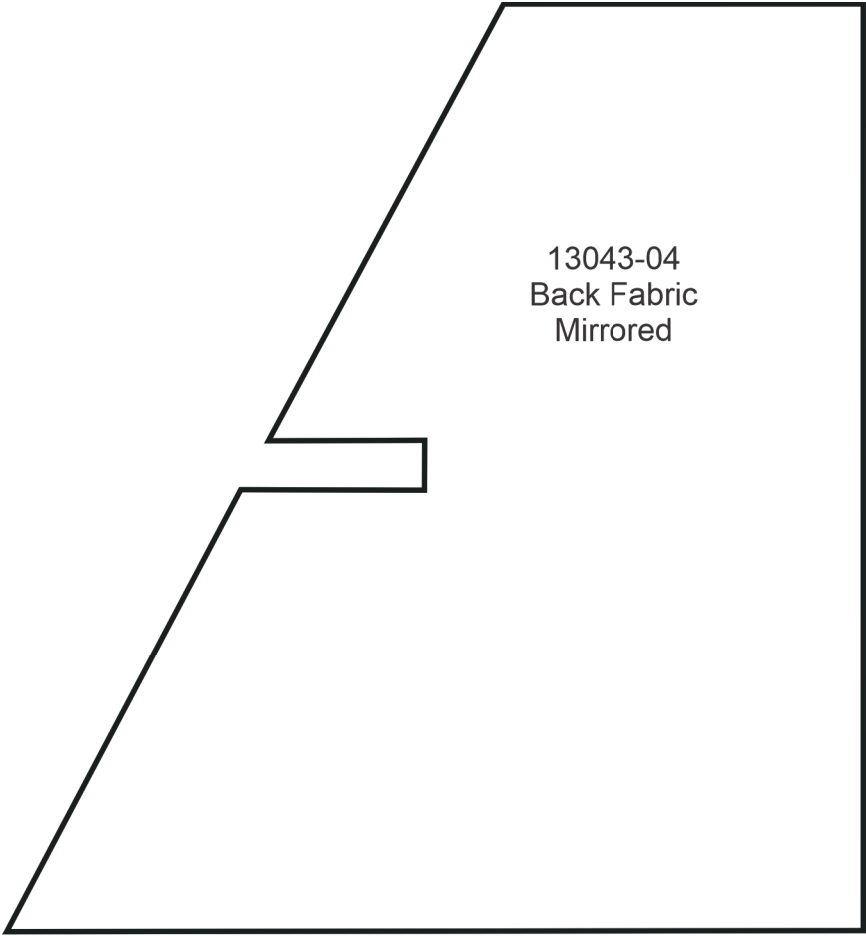

# MIRRORED PATTERNS



Print at 100%. No scaling. This box measures 1" x 1". Use the box as an accuracy guide when printing templates.

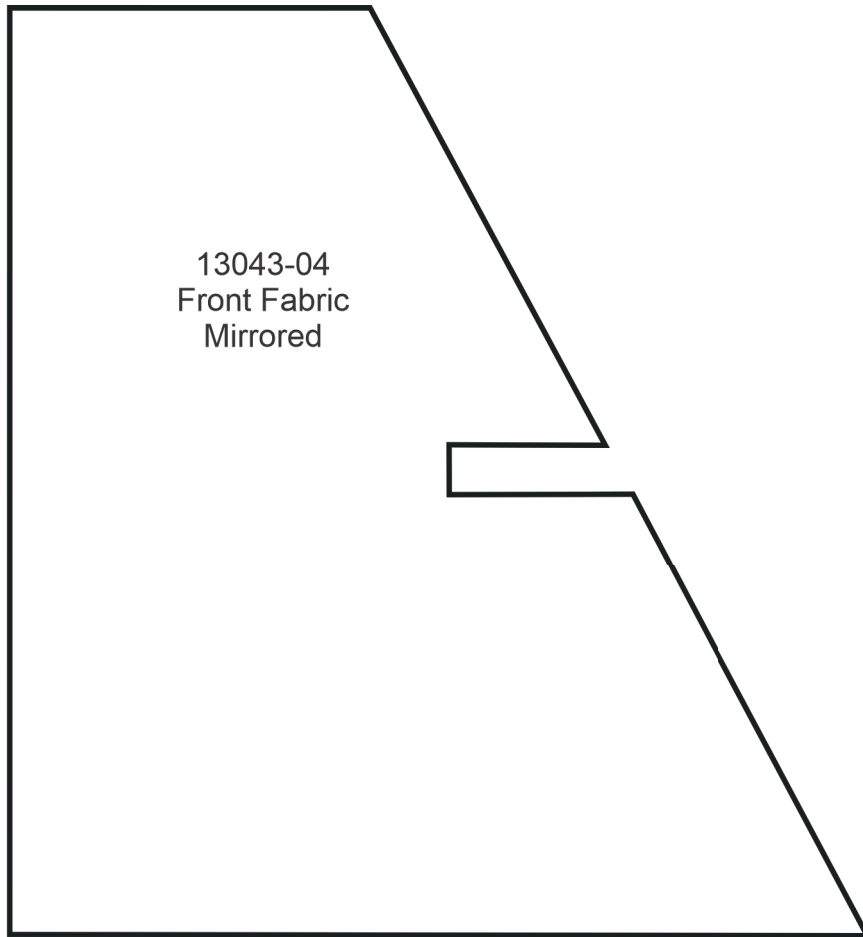

# MIRRORED PATTERNS



Print at 100%. No scaling. This box measures 1" x 1". Use the box as an accuracy guide when printing templates.

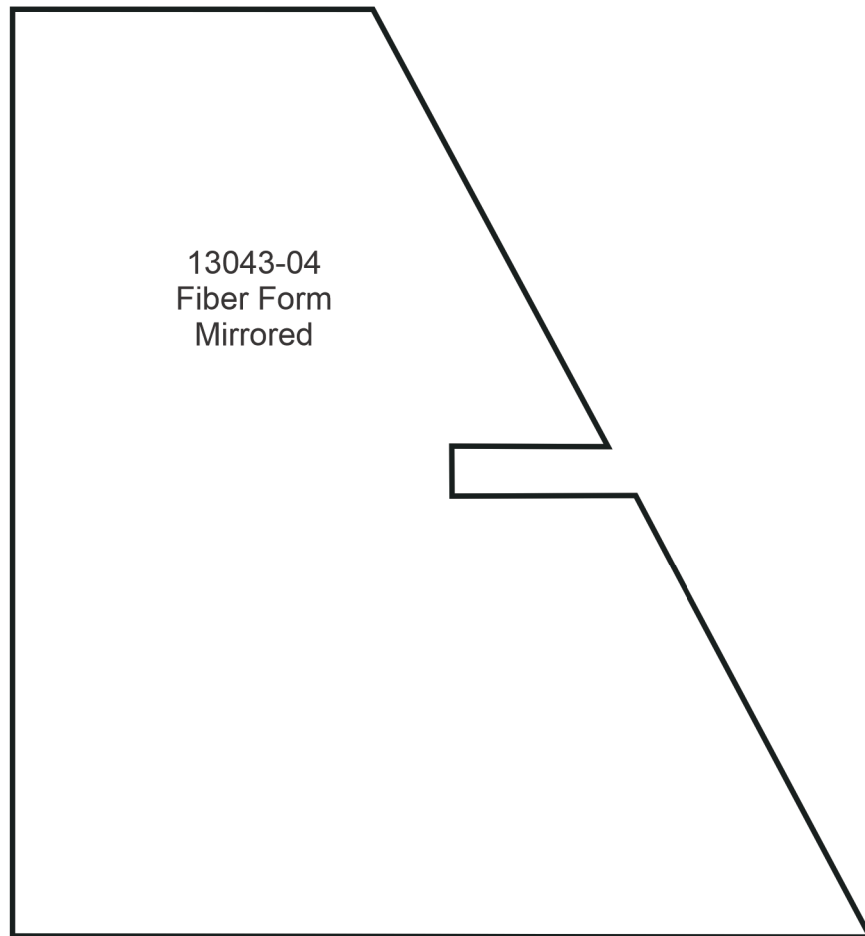

# MIRRORED PATTERNS



Print at 100%. No scaling. This box measures 1" x 1". Use the box as an accuracy guide when printing templates.

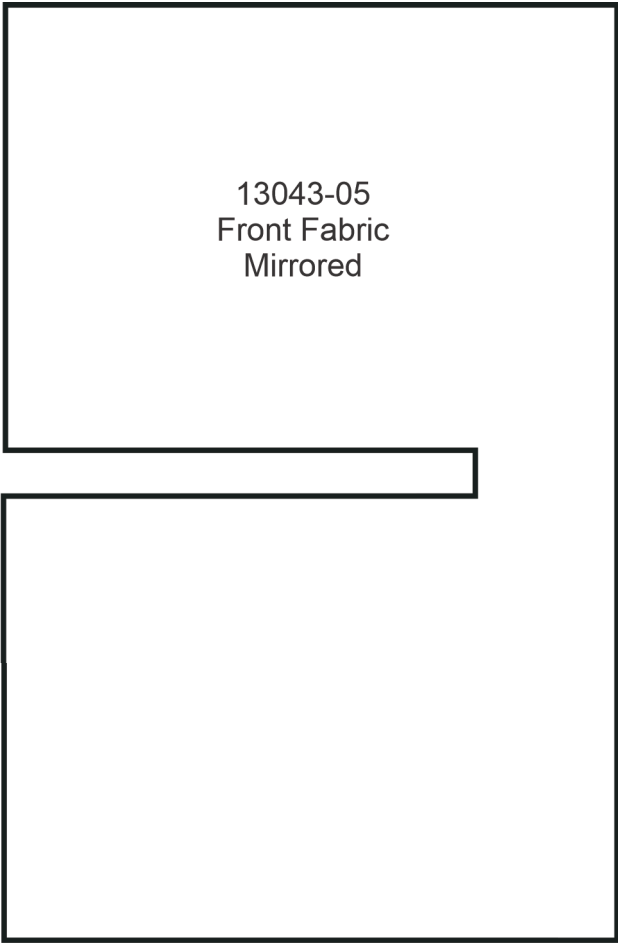
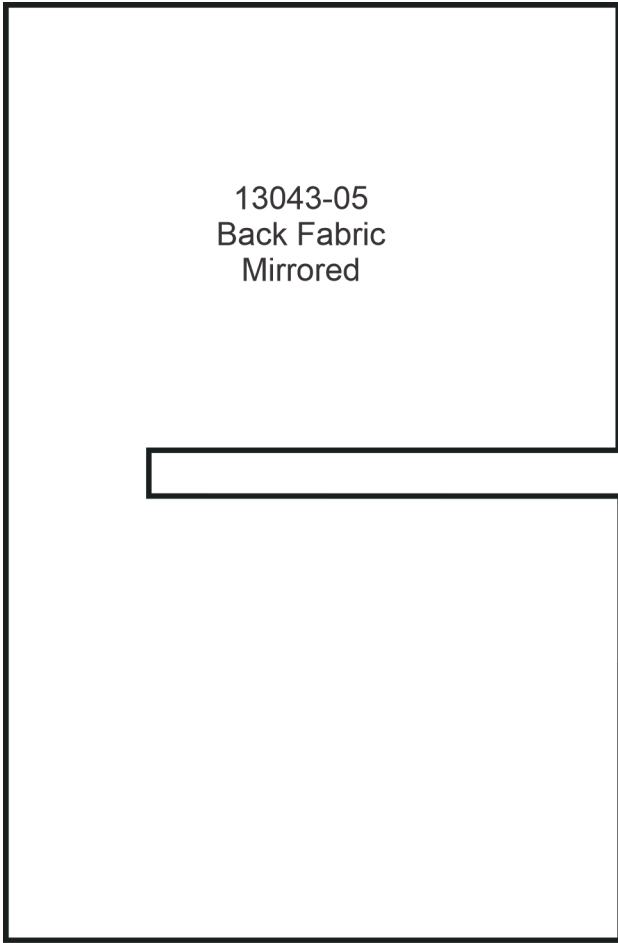

# MIRRORED PATTERNS



Print at 100%. No scaling. This box measures 1" x 1". Use the box as an accuracy guide when printing templates.

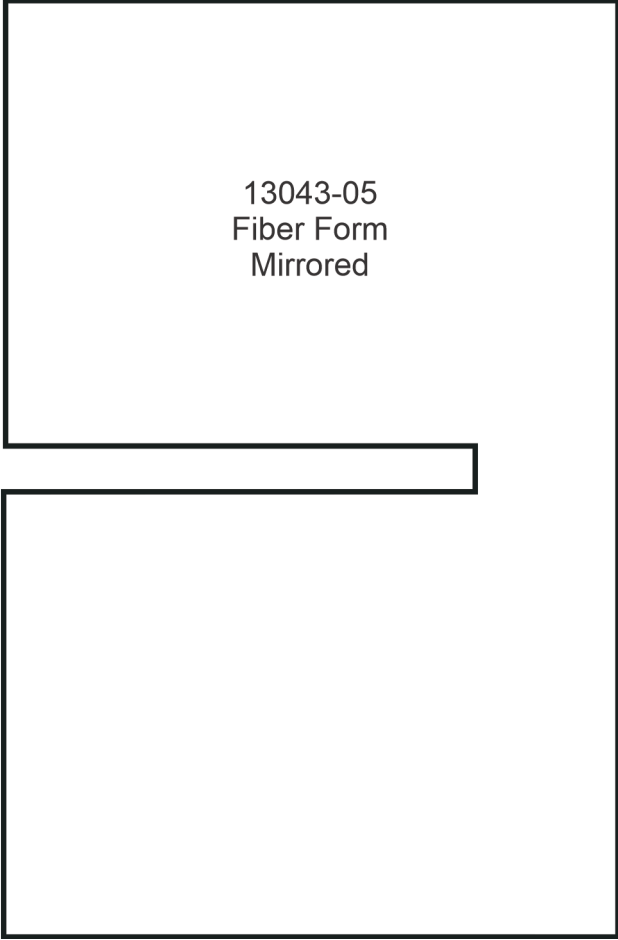

# MIRRORED PATTERNS



Print at 100%. No scaling. This box measures 1" x 1". Use the box as an accuracy guide when printing templates.

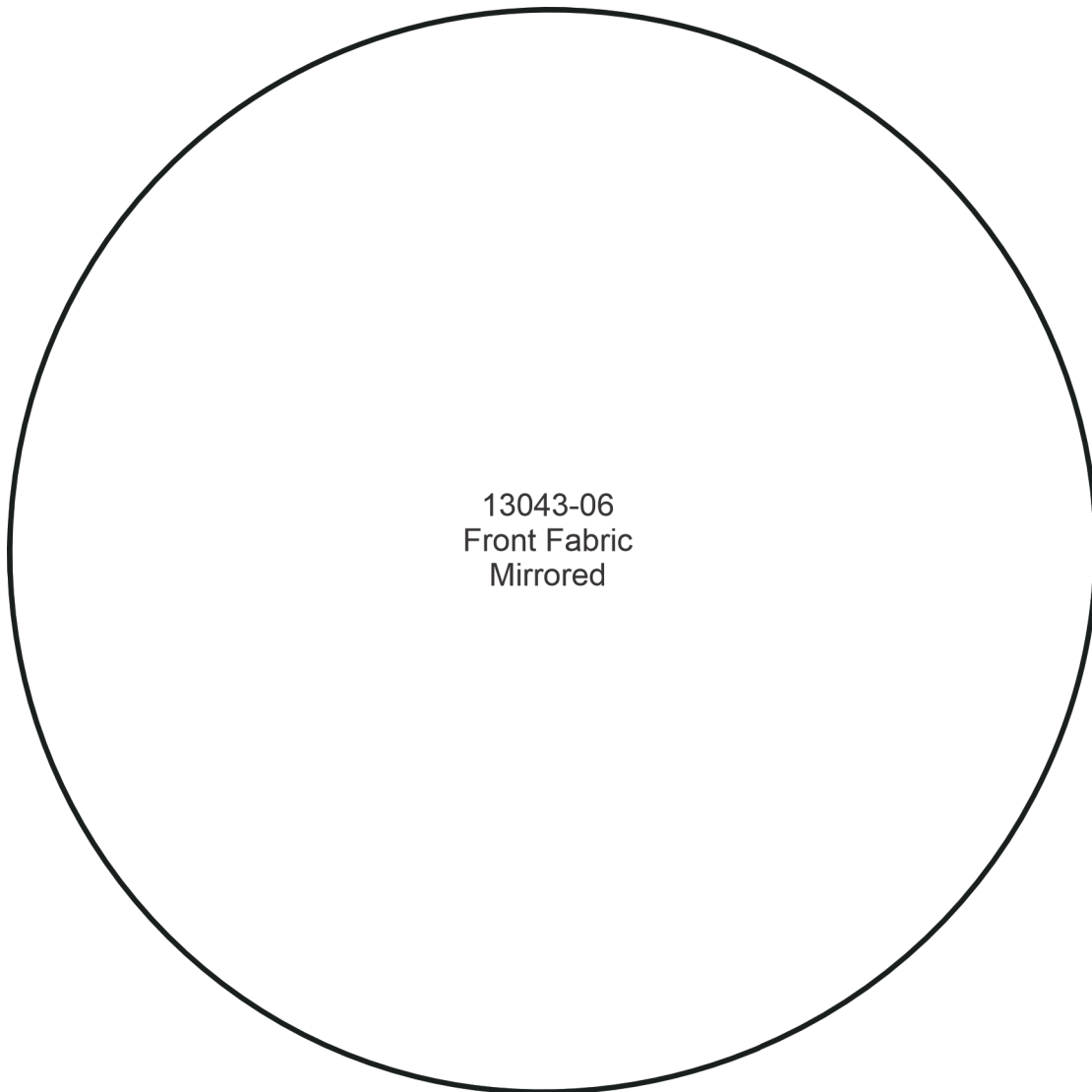

13043-06  
Front Fabric  
Mirrored

# MIRRORED PATTERNS



Print at 100%. No scaling. This box measures 1" x 1". Use the box as an accuracy guide when printing templates.

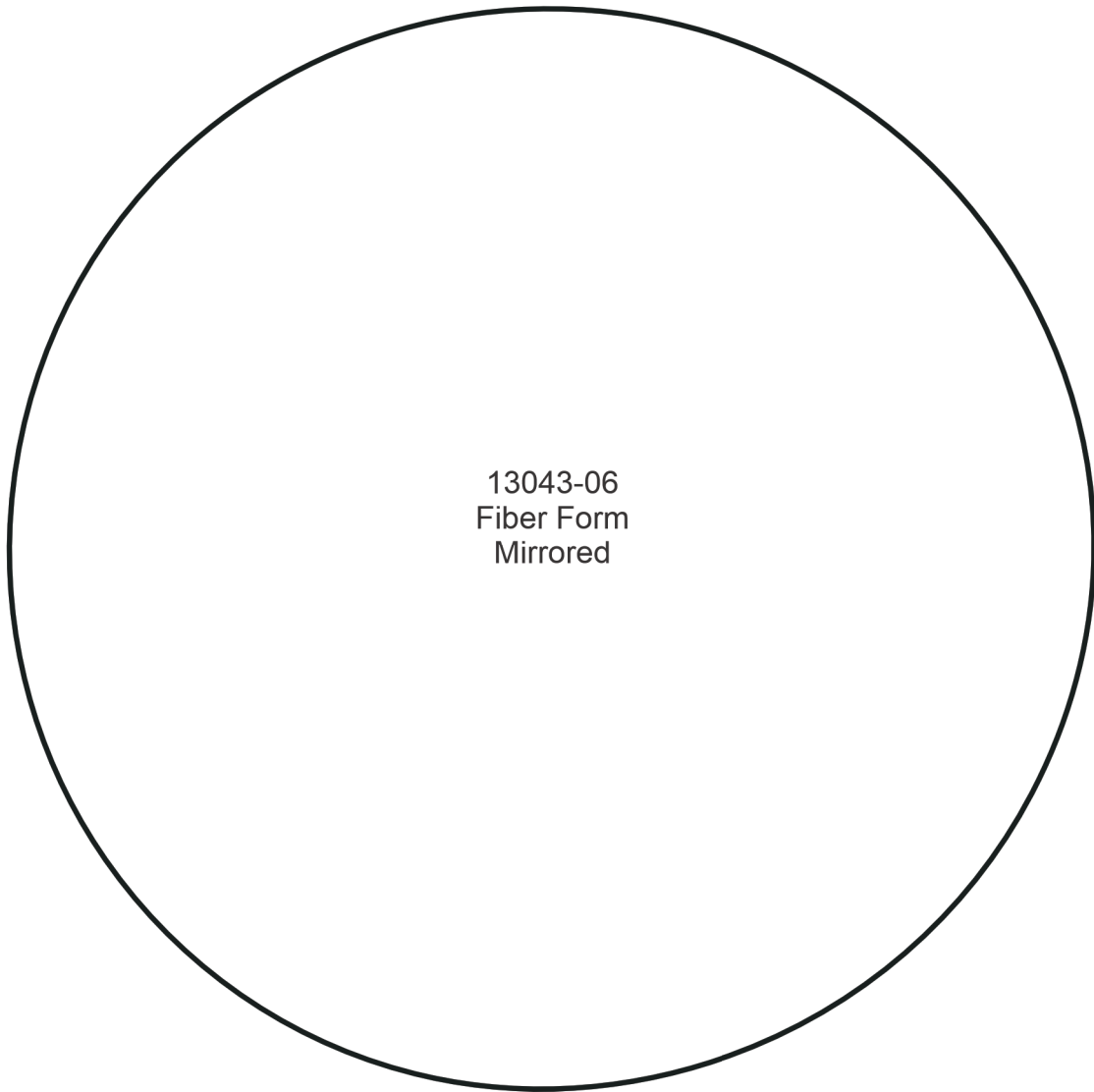

13043-06  
Fiber Form  
Mirrored

# MIRRORED PATTERNS



Print at 100%. No scaling. This box measures 1" x 1". Use the box as an accuracy guide when printing templates.

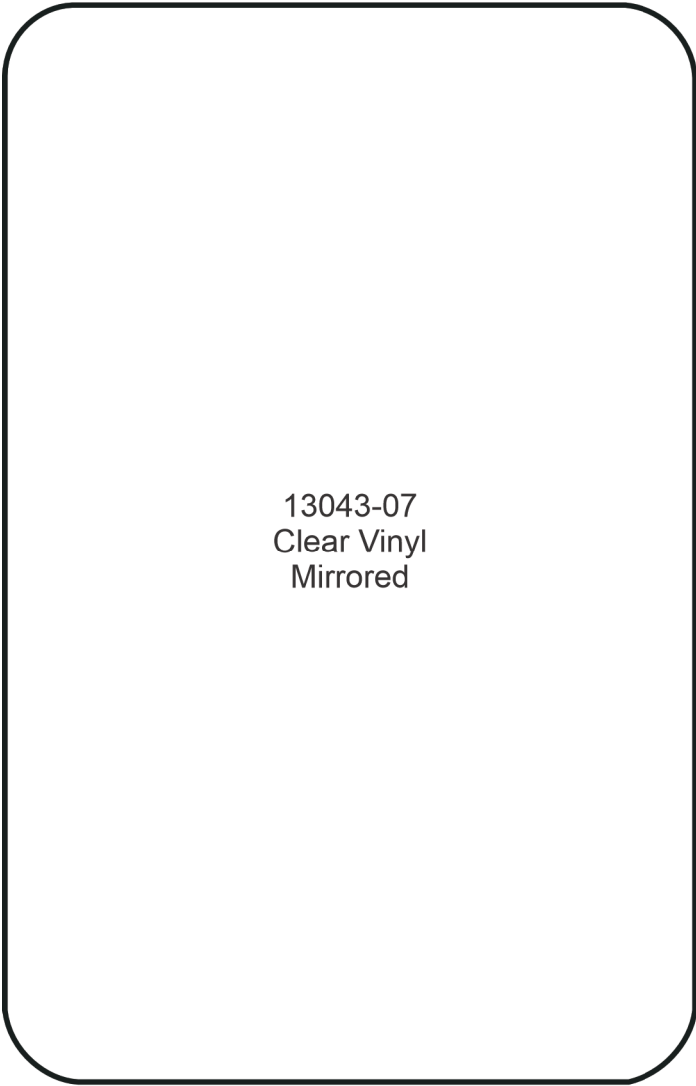

# MIRRORED PATTERNS



Print at 100%. No scaling. This box measures 1" x 1". Use the box as an accuracy guide when printing templates.

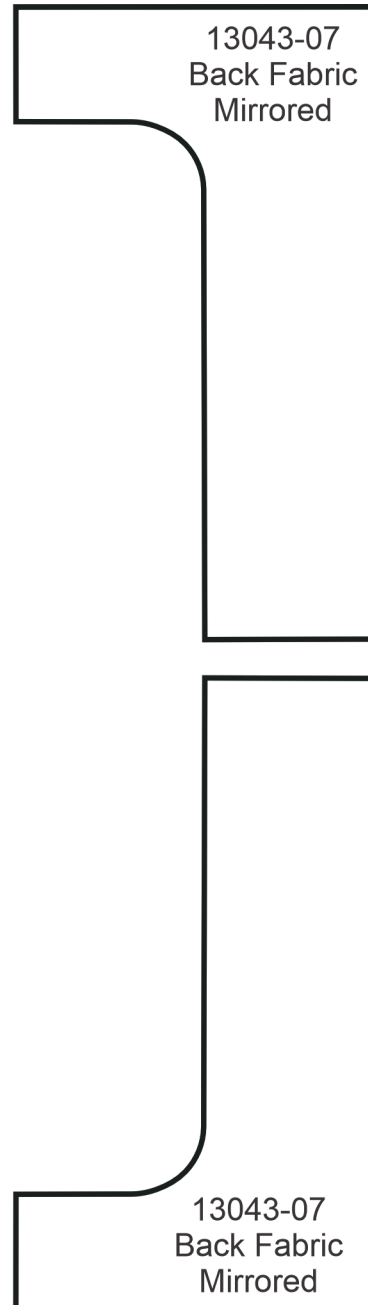

# MIRRORED PATTERNS



Print at 100%. No scaling. This box measures 1" x 1". Use the box as an accuracy guide when printing templates.

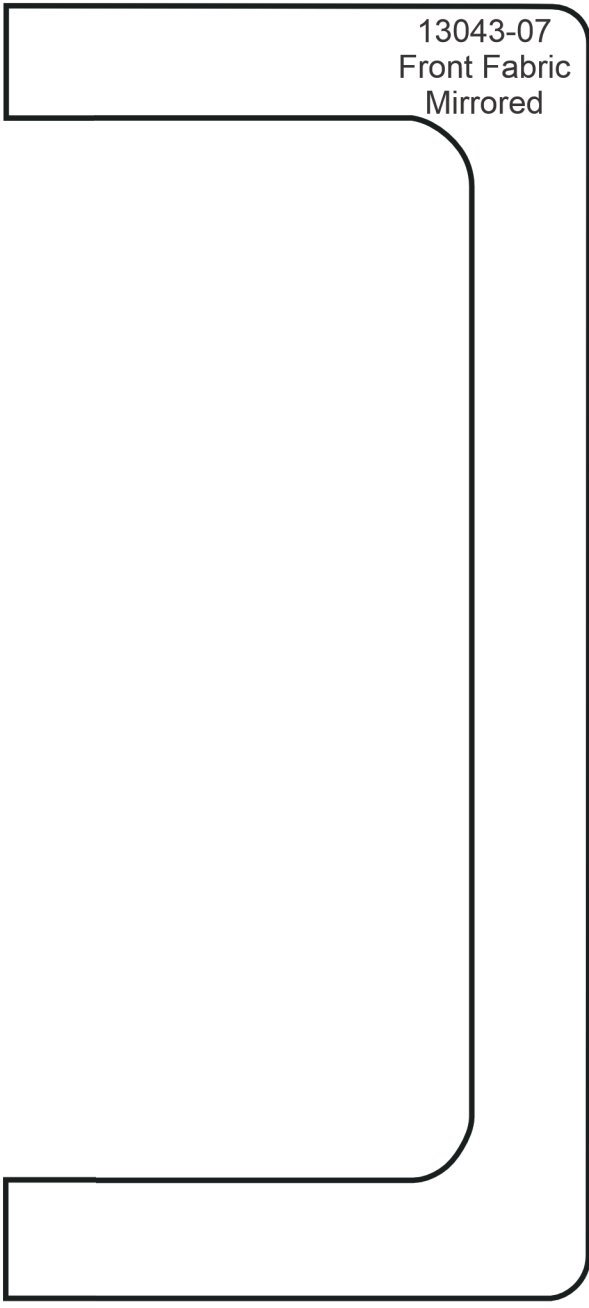
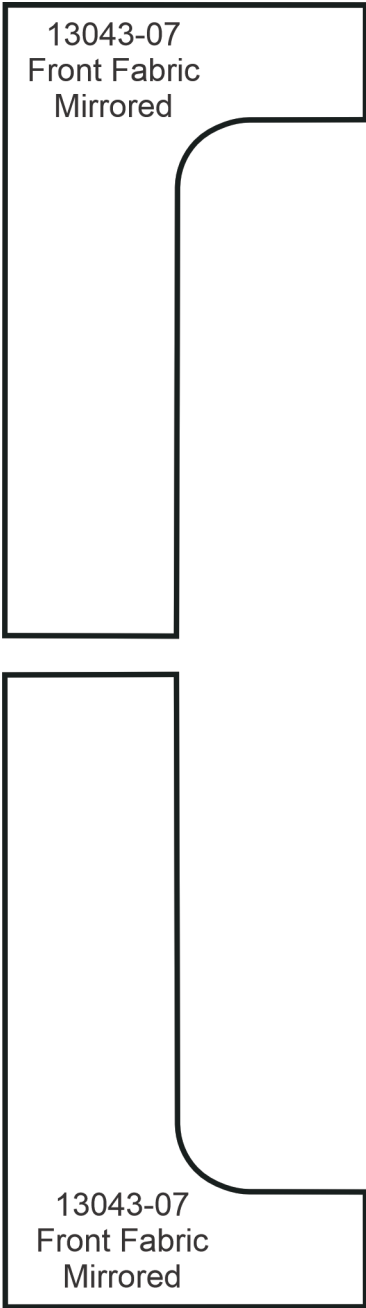

# MIRRORED PATTERNS



Print at 100%. No scaling. This box measures 1" x 1". Use the box as an accuracy guide when printing templates.

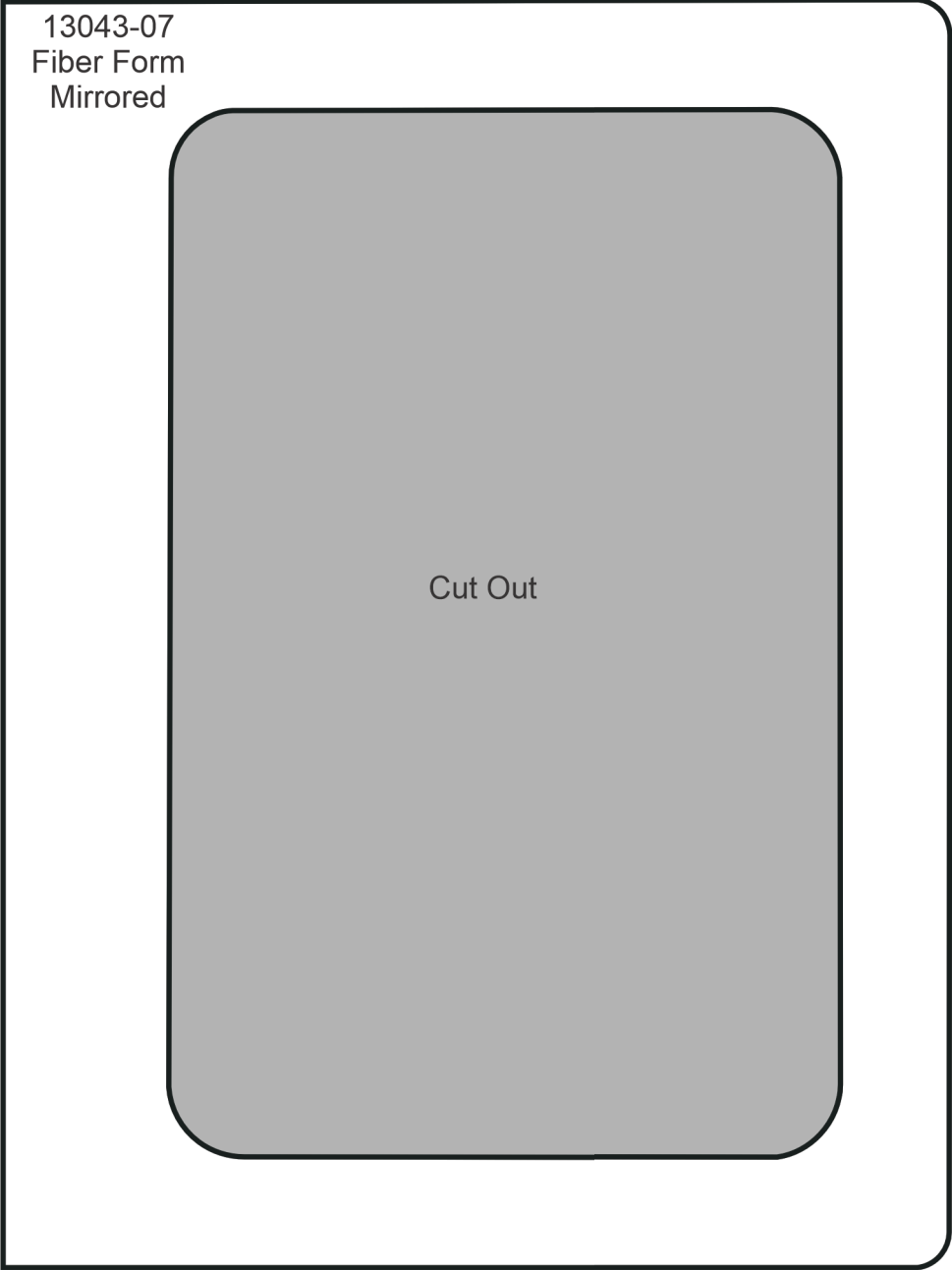

# MIRRORED PATTERNS

Print at 100%. No scaling. This box measures 1" x 1". Use the box as an accuracy guide when printing templates.

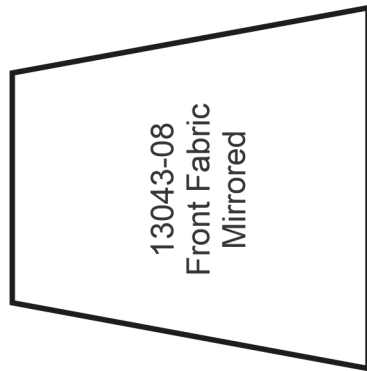
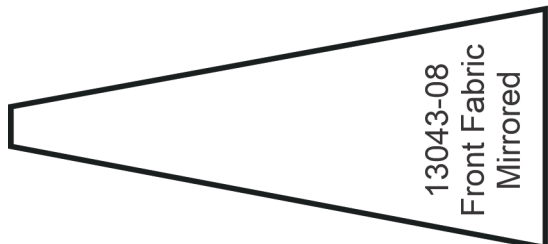
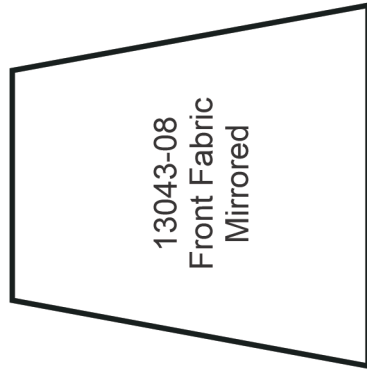
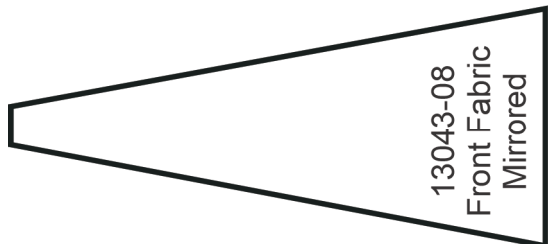
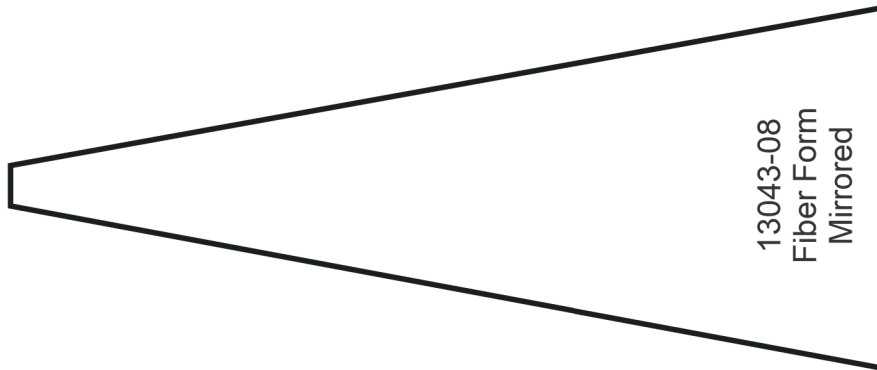
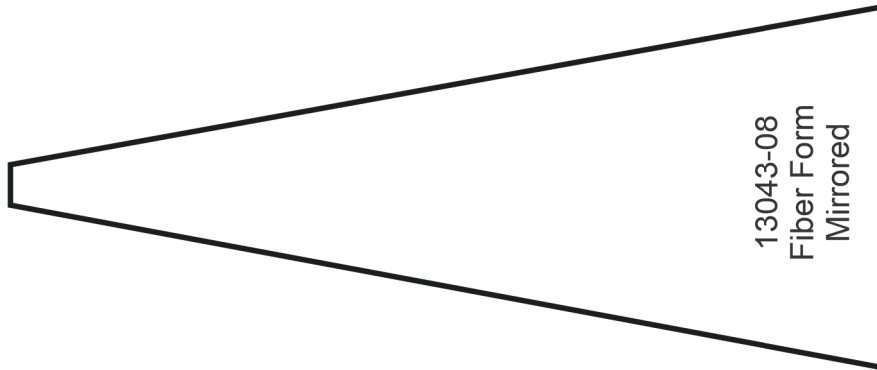

# MIRRORED PATTERNS



Print at 100%. No scaling. This box measures 1" x 1". Use the box as an accuracy guide when printing templates.

13043-09  
Back Fabric  
Mirrored

# MIRRORED PATTERNS



Print at 100%. No scaling. This box measures 1" x 1". Use the box as an accuracy guide when printing templates.

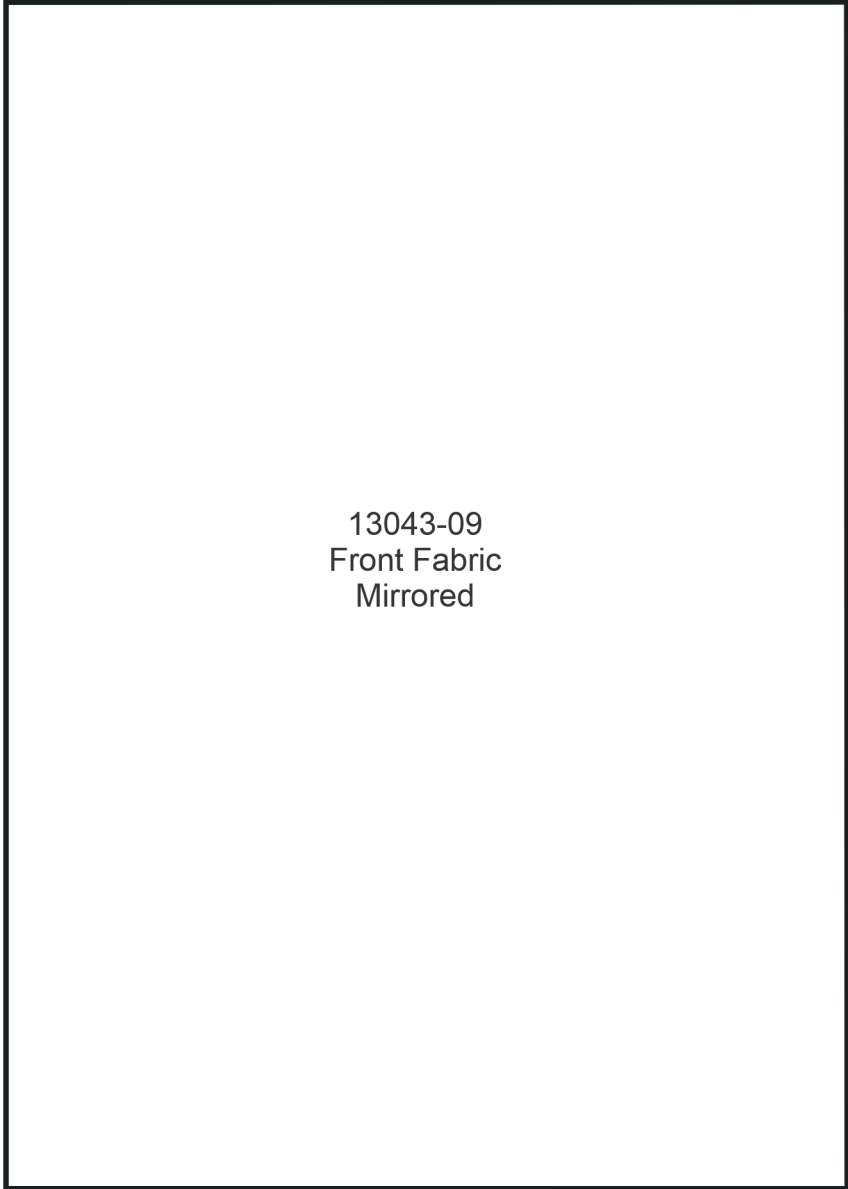

13043-09  
Front Fabric  
Mirrored

# MIRRORED PATTERNS



Print at 100%. No scaling. This box measures 1" x 1". Use the box as an accuracy guide when printing templates.

13043-09  
Fiber Form  
Mirrored

# MIRRORED PATTERNS



Print at 100%. No scaling. This box measures 1" x 1". Use the box as an accuracy guide when printing templates.

13043-10  
Front Fabric  
Mirrored

# MIRRORED PATTERNS



Print at 100%. No scaling. This box measures 1" x 1". Use the box as an accuracy guide when printing templates.

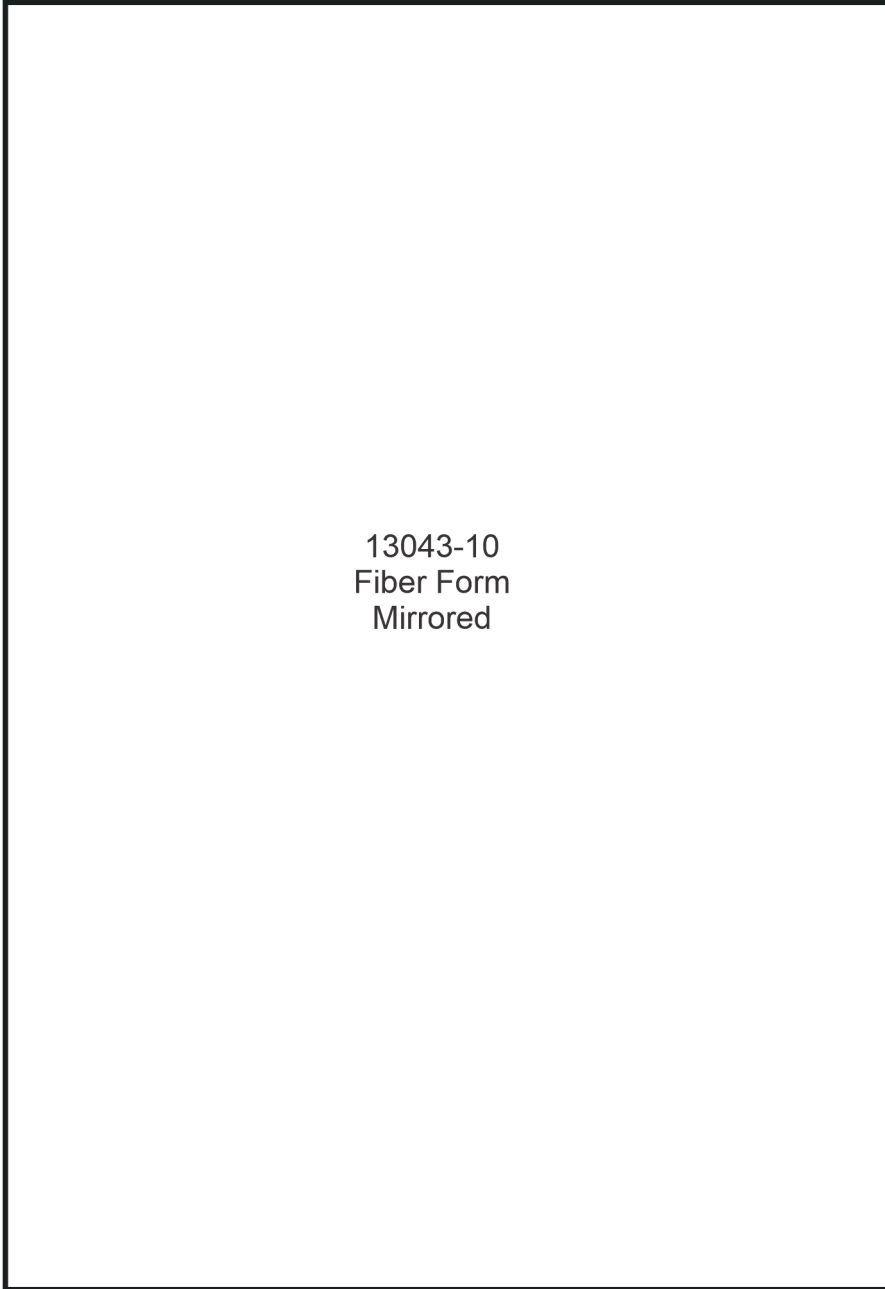

13043-10  
Fiber Form  
Mirrored

# MIRRORED PATTERNS



Print at 100%. No scaling. This box measures 1" x 1". Use the box as an accuracy guide when printing templates.

13043-11  
Front Fabric  
Mirrored

13043-11  
Fiber Form  
Mirrored

# MIRRORED PATTERNS



Print at 100%. No scaling. This box measures 1" x 1". Use the box as an accuracy guide when printing templates.

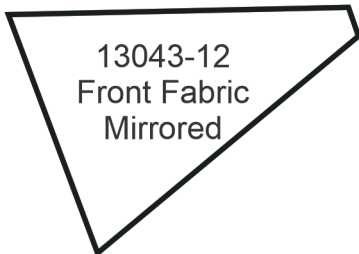
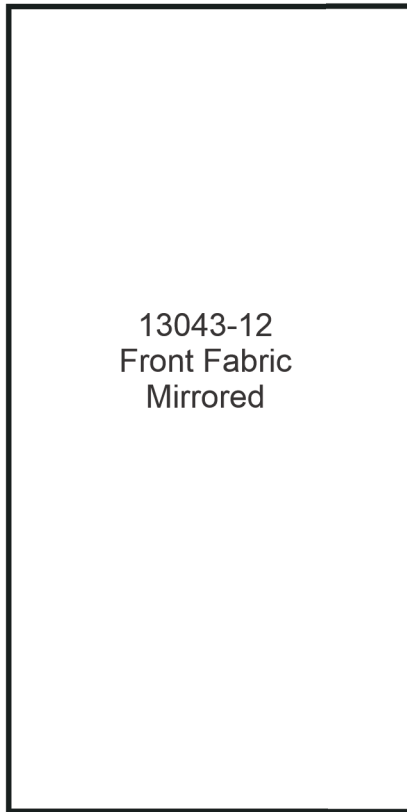
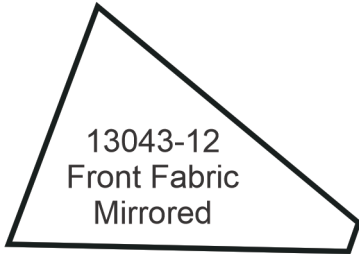

# MIRRORED PATTERNS



Print at 100%. No scaling. This box measures 1" x 1". Use the box as an accuracy guide when printing templates.

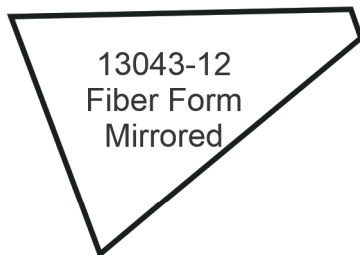
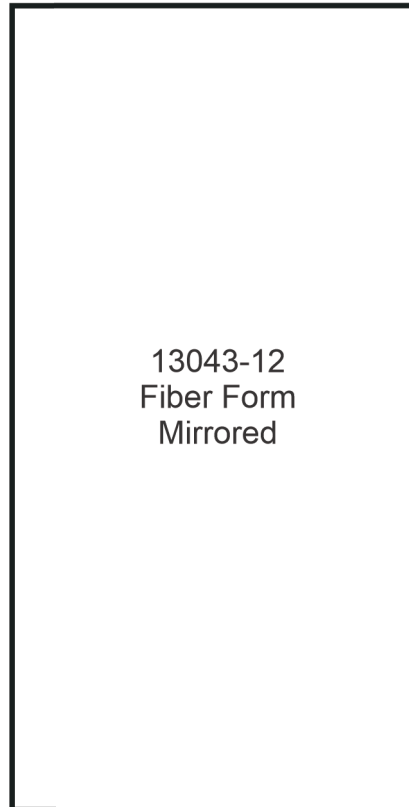
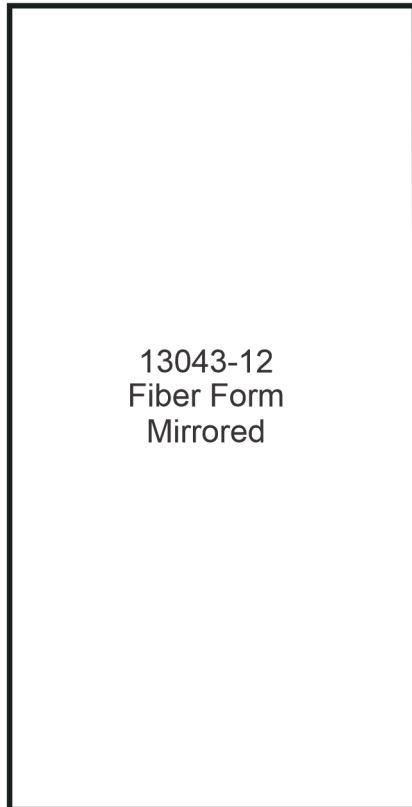
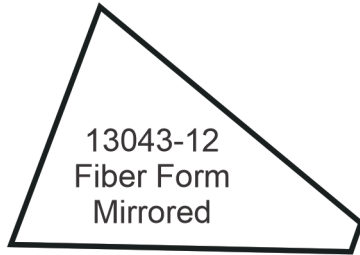

# MIRRORED PATTERNS



Print at 100%. No scaling. This box measures 1" x 1". Use the box as an accuracy guide when printing templates.

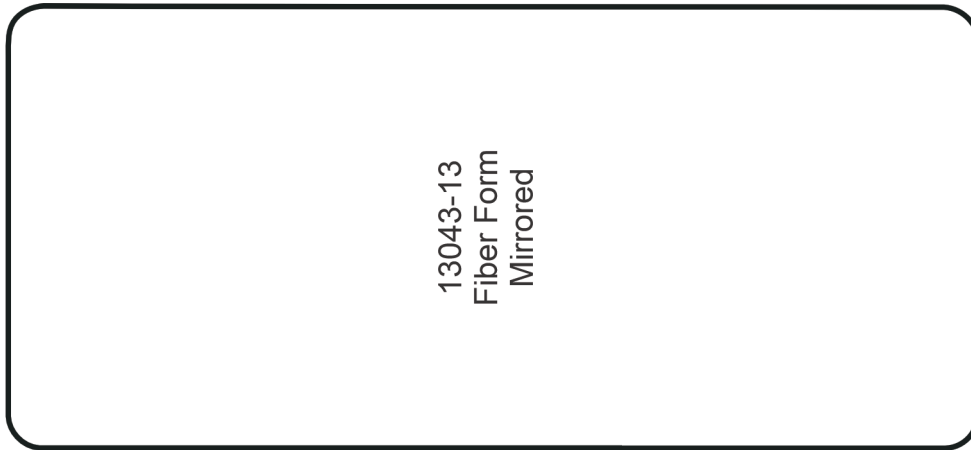

13043-13  
Fiber Form  
Mirrored

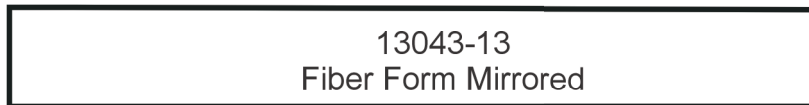

13043-13  
Fiber Form Mirrored

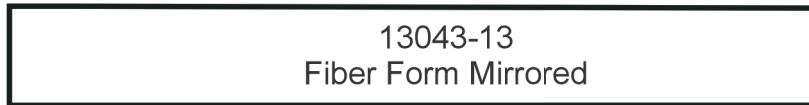

13043-13  
Fiber Form Mirrored

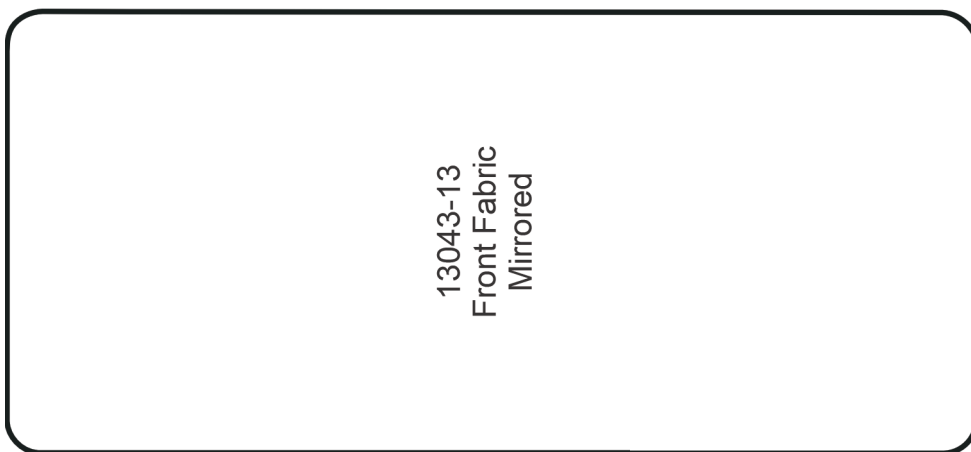

13043-13  
Front Fabric  
Mirrored



13043-13  
Front Fabric Mirrored



13043-13  
Front Fabric Mirrored

# MIRRORED PATTERNS



Print at 100%. No scaling. This box measures 1" x 1". Use the box as an accuracy guide when printing templates.

13043-13  
Back Fabric Mirrored

13043-13  
Back Fabric Mirrored

13043-13  
Back Fabric  
Mirrored