



Scissortail  
STITCHES

#51256  
2 DESIGNS



## FREESTANDING UMBRELLAS

It is a violation of Copyright law to make and distribute copies of electronic designs or artwork.  
Electronic designs are licensed to the original purchaser for use at one location. ©2021 OESD, LLC. All rights reserved.

# MATERIALS



## Isacord Thread Colors

3650 Ice Cap  
4740 Aquamarine  
5220 Silver Sage

**\*Project instructions included after design list**

# DESIGNS



Note: Some designs in this collection may have been created using unique special stitches and/or techniques. To preserve design integrity when rescaling or rotating designs in your software, always rescale or rotate designs using the handles directly on-screen.

## FABRIC REQUIRED

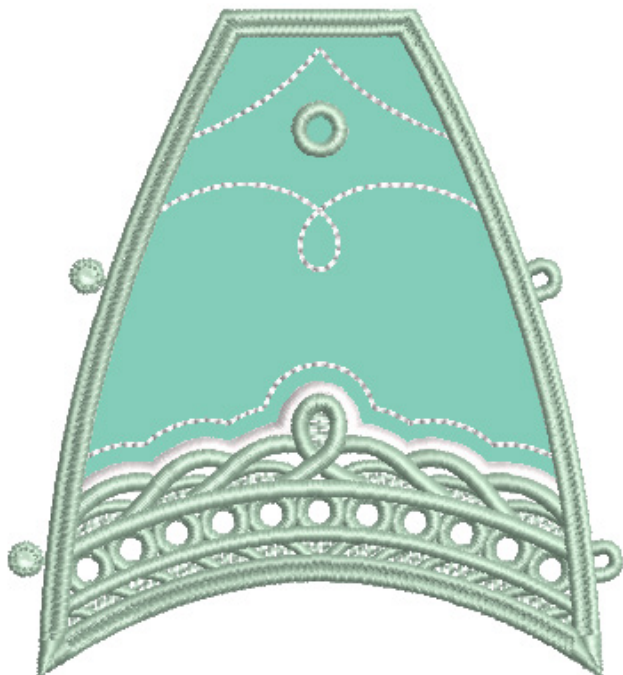

## 51256-01 Umbrella Section FSA

Size Inches:                      Size mm:                      Stitch Count:  
**4.38 X 4.04 in.    111.4 X 102.6 mm    14885 St.**

- 1. Front and Back Fabric Placement Stitch 3650
- 2. Cut Line and Tackdown..... 3650
- 3. Light Blue Detail..... 3650
- 4. Green Cover Stitch and Lace.....5220

## FABRIC REQUIRED



## 51256-02 Umbrella Top FSA

Size Inches:                      Size mm:                      Stitch Count:  
**2.19 X 2.52 in.    55.5 X 64.1 mm    3695 St.**

- 1. Front and Back Fabric Placement Stitch 3650
- 2. Cut Line and Tackdown..... 3650
- 3. Light Blue Detail..... 3650
- 4. Green Cover Stitch.....5220



# DESIGNS



Note: Some designs in this collection may have been created using unique special stitches and/or techniques. To preserve design integrity when rescaling or rotating designs in your software, always rescale or rotate designs using the handles directly on-screen.

## FABRIC REQUIRED

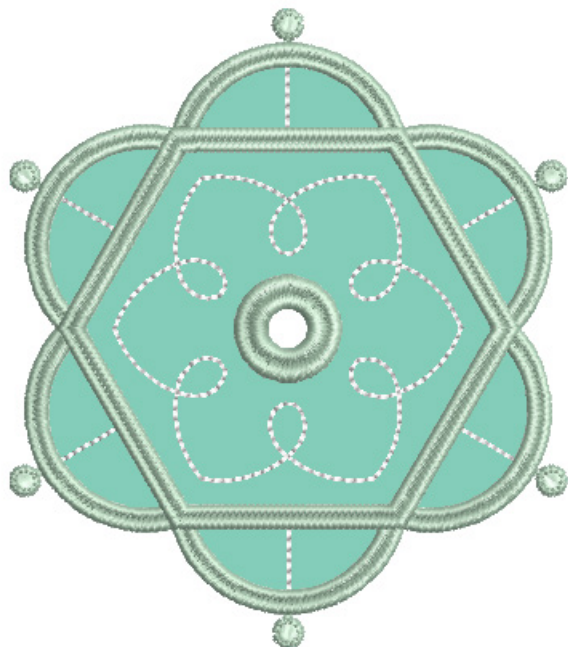

### 51256-03 Umbrella Brace FSA

Size Inches:                      Size mm:                      Stitch Count:  
**4.67 X 4.08 in.    118.6 X 103.5 mm    10341 St.**

- 1. Front and Back Fabric Placement Stitch 3650
- 2. Cut Line and Tackdown..... 3650
- 3. Light Blue Detail..... 3650
- 4. Green Cover Stitch.....5220

## FABRIC REQUIRED

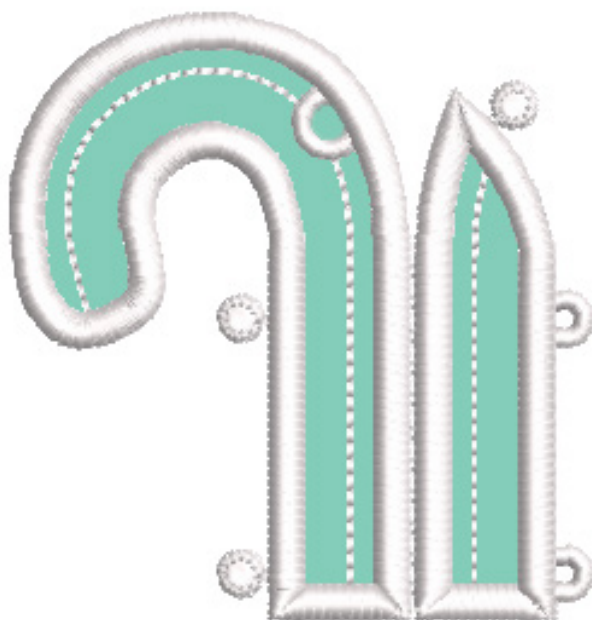

### 51256-04 Umbrella Handle FSA

Size Inches:                      Size mm:                      Stitch Count:  
**2.96 X 2.84 in.    75.1 X 72.2 mm    5068 St.**

- 1. Front and Back Fabric Placement Stitch 3650
- 2. Cut Line and Tackdown..... 3650
- 3. Light Blue Cover Stitch ..... 3650

# DESIGNS



Note: Some designs in this collection may have been created using unique special stitches and/or techniques. To preserve design integrity when rescaling or rotating designs in your software, always rescale or rotate designs using the handles directly on-screen.

## 51256-05 Umbrella Section FSL

Size Inches:                      Size mm:                      Stitch Count:  
**4.38 X 4.04 in.    111.4 X 102.6 mm    31061 St.**

- 1. Light Blue Lace ..... 3650
- 2. Light Green Lace .....4740
- 3. Dark Green Lace.....5220

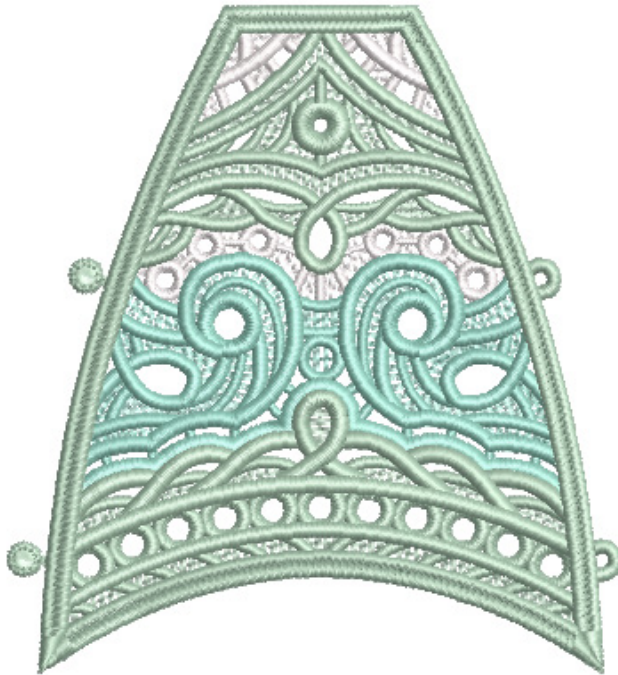

## 51256-06 Umbrella Top FSL

Size Inches:                      Size mm:                      Stitch Count:  
**2.19 X 2.52 in.    55.5 X 64.1 mm    10230 St.**

- 1. Light Blue Lace ..... 3650
- 2. Dark Green Lace.....5220



# DESIGNS



Note: Some designs in this collection may have been created using unique special stitches and/or techniques. To preserve design integrity when rescaling or rotating designs in your software, always rescale or rotate designs using the handles directly on-screen.

## 51256-07 Umbrella Brace FSL

Size Inches:                      Size mm:                      Stitch Count:  
**4.67 X 4.08 in.    118.6 X 103.5 mm    32801 St.**



- 1. Light Blue Lace ..... 3650
- 2. Light Green Lace ..... 4740
- 3. Dark Green Lace ..... 5220

## 51256-08 Umbrella Handle FSL

Size Inches:                      Size mm:                      Stitch Count:  
**2.96 X 2.84 in.    75.2 X 72.1 mm    10991 St.**



- 1. Single Color Design ..... 3650

# MATERIALS



## Stabilizer

- OESD AquaMesh
- OESD BadgeMaster
- OESD StabilStick CutAway

## Fabrics/Textiles

Fabrics/Textiles shown in instructions:

- Solid Light Blue Fabric for outer 3 sections and Handle - ¼ yd
- Solid Light Green Fabric for outer 3 sections and Top - ¼ yd
- Polka Dot Light Blue Fabric for inner 3 sections - ¼ yd
- Polka Dot Light Green Fabric for inner 3 sections and Brace - ¼ yd
- Sewing in one fabric color - 1/3 yd
- **Note:** Fabric sizes are estimates and may result in overage.

Cut Fabrics:

- Each Applique piece is double sided.
- 4.5" x 4.5" Umbrella sections 12 required
- 3" x 3" Umbrella Top 2 required
- 5" x 5" Umbrella Brace 2 required
- 3.5" x 3.5" Umbrella Handle 2 required

## Notion/Tools

- OESD Alligator Clamps
- OESD Button Clips
- OESD Expert Embroidery Tape WashAway
- OESD Expert Point and Press Tool
- OESD Expert Punch Tool
- OESD Perfect Embroidery Press Cloth
- 5/16" Dowel cut to 8" long
- Organ Titanium Sharp Needle 75/11

## Isacord Thread Colors

- As per thread chart
- Match bobbin thread to top thread
- No design requires more than one spool.



# SUMMARY



## FREESTANDING APPLIQUE UMBRELLA

51256-01

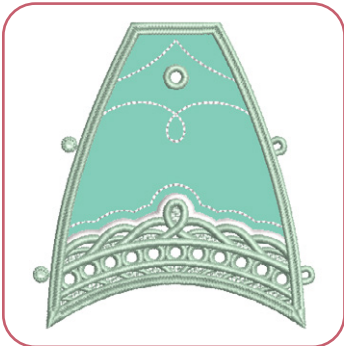

Requires 6 Designs

51256-02

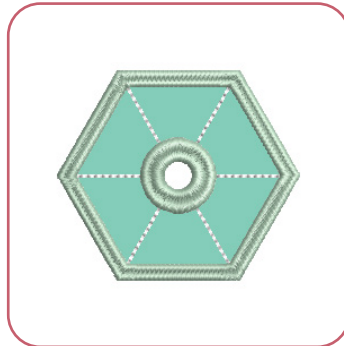

Requires 1 Design

51256-03

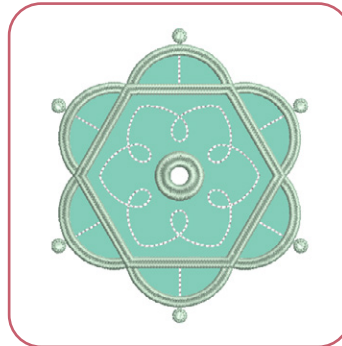

Requires 1 Design

51256-04



Requires 1 Design

## FREESTANDING LACE UMBRELLA

51256-05



Requires 6 Designs

51256-06

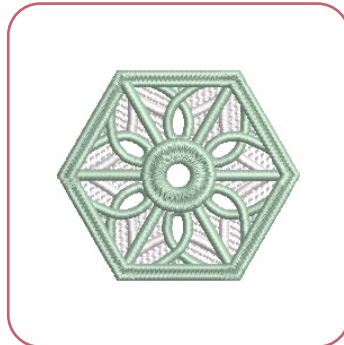

Requires 1 Design

51256-07



Requires 1 Design

51256-08



Requires 1 Design

**\*The applique instructions included in the design pack are general instructions for the collection. For demonstration purposes, a sample design that best represents the entire collection is shown. Fabric and thread requirements will vary by design, but the general technique will be the same.**



# GENERAL FREESTANDING LACE GUIDE



## Stabilizer

- OESD AquaMesh
- OESD BadgeMaster

## Notion/Tools

- 80/12 Embroidery Ballpoint Titanium needle for extended needle life
- OESD Alligator Clamps
- OESD Button Clips
- OESD Perfect Point and Press Tool

## Isacord Thread Colors

- All OESD designs are digitized with Isacord 40 wt. polyester thread as the top thread and in the bobbin.
- Refer to the thread chart for color specifications.
- Match bobbin thread color to the top thread.

## Instructions

### Step 1 - Hoop

For FSL structures, hoop one layer of OESD AquaMesh and one layer of OESD BadgeMaster. BadgeMaster contains more starch so, combined with the AquaMesh, the lace is more rigid.

For other FSL, where a softer lace is desired, hoop two layers of AquaMesh.

### Step 2 - Embroider

Stitch the design per the thread chart with matching thread in the bobbin at each color change.

When complete, remove from the hoop and trim away excess stabilizer about 1/4"-1/2" from the stitching.

### Step 3 - Rinse

Rinse remaining stabilizer out in warm running water.

For stiffer lace and FSL structures, DO NOT rinse away all of the stabilizer. The lace should be just slightly tacky.

For softer lace, rinse until all traces of the stabilizer is removed.

### Step 4 - Dry

Lay right side down flat on a non-stick surface, such as a cookie rack, parchment paper or Teflon sheet. This minimizes the tendency for the lace to curl.

Let the pieces dry completely before proceeding with any assembly.

### Step 5 - Press

Once completely dry, press right side down on a OESD Perfect Embroidery Press Cloth.

### Step 6 - Assemble Structure

Note: Specific assembly instructions for a design/collection may be found in the thread chart pdf following the individual design color charts.

Lace must be COMPLETELY DRY before assembly. Wetting the buttonettes or eyelets to assemble is not recommended and may result in them stretching and coming "unbuttoned" when dry.

Use a pair of OESD Alligator Clamps to insert the buttonettes into the eyelets. Insert the tip of the OESD Alligator Clamps into the eyelet, grasp the buttonette and pull through the eyelet. Alternatively, use a stiletto or tweezers to push the buttonette through the eyelet.

## Helpful Tips

### Limp Lace

If the design is not stiff enough, press the lace pieces on the wrong side while applying spray starch. After ironing, spray again with starch and allow to dry completely. This will stiffen the lace pieces nicely and aid in construction. Or easily re-stiffen by diluting some stabilizer scraps in water (or use liquid starch) and dipping the item in the solution. Lay flat to dry.

### Eyelets Too Small

If any of the eyelets appear closed or too small to penetrate with Alligator Clamps, they may be stretched by inserting the small end of the OESD Perfect Point and Press Tool into the eyelet opening and stretching it open wide enough to accommodate the OESD Alligator Clamps.

### Button Clips

During the assembly process, some structures pull on buttonettes that have already been inserted and could pull them out altogether. Putting a Button Clip on the assembled buttonette will keep it in position during the assembly process.

Remove the Button Clips when the assembly is complete.

### Alternative Construction Option

In some cases, the buttonettes may be pulled to the inside of a project, instead of being visible on the outside.

Insert the OESD Alligator Clamps through the eyelet from the wrong, or inside, of the lace and grasp the corresponding buttonette. Pull the buttonette to the wrong side of the lace.

Pulling the buttonettes to the inside may cause stress on the ones already done. Button clips may be placed on the completed buttonette(s) to prevent them from pulling out of the eyelet.

# EMBROIDERY



## Step 1

- The project includes freestanding applique designs and freestanding lace designs.
- All applique designs are stitched the same as shown in the instructions.
- All designs are stitched with matching thread in the top and bobbin.
- Hoop one layer of AquaMesh and one layer of BadgeMaster in the hoop for all designs.



## Step 2

- Prep the front and back applique fabrics with one layer of StabilStick CutAway.

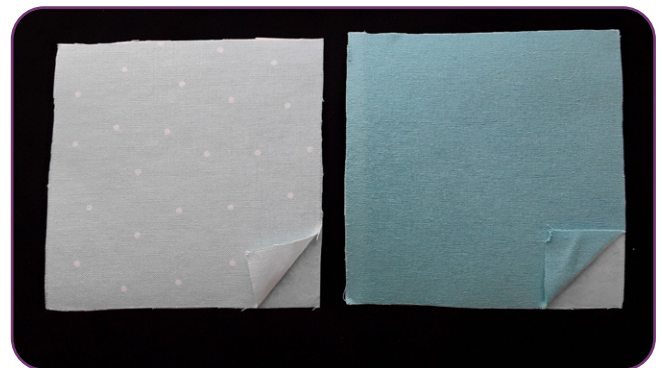

## Step 3

- Stitch Machine Step 1, Front and Back Placement Stitch.



# EMBROIDERY



## Step 4

- Remove the hoop from the machine, but NOT the project from the hoop.
- Lay the hoop on a flat surface.
- Cut a piece of prepared fabric slightly larger than the placement line.
- Place the prepared fabric right side up covering the placement line completely.
- Tape with OESD Expert Embroidery Tape WashAway to secure.

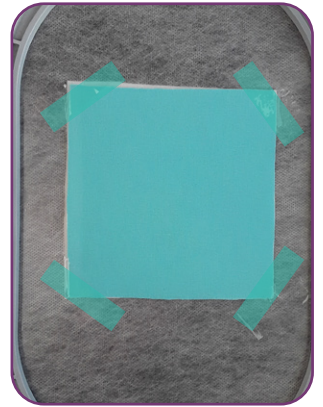

## Step 5

- Turn the hoop over and place the back prepared fabric right side up covering the placement stitch completely.
- Tape to secure with OESD Expert Embroidery Tape WashAway. Avoid pushing too hard on the stabilizer to prevent it from dislodging from the hoop.



## Step 6

- Return the hoop to the machine.
- Stitch Machine Step 2, Cut Line and Tackdown.

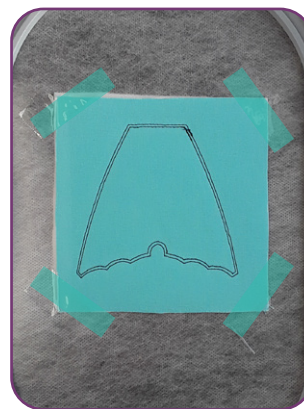



# EMBROIDERY



## Step 7

- Remove the hoop from the machine, but NOT the project from the hoop.
- Trim the excess fabric as close to the tackdown stitching as possible. If the outermost stitches are cut, the inner stitches will still hold the applique in place.



## Step 8

- When stitching Top 02 and Brace 03, after Machine Step 2, cut out the center completely. Use OESD Expert Embroidery WashAway tape to patch the hole.



# EMBROIDERY



## Step 9

- Return the hoop to the machine and stitch the remaining machine steps according to the thread chart.
- Match the bobbin thread to the upper thread colors.



## Step 10

- When design is complete, remove the project from the hoop and trim the stabilizer 1/4" - 1/2" outside the design.



# ASSEMBLY



## Step 1

- Rinse each piece in warm running water until the design is only slightly sticky.
- Lay face down on a non-stick surface to dry. Parchment paper or a cooling rack work well. This prevents the piece from curling.

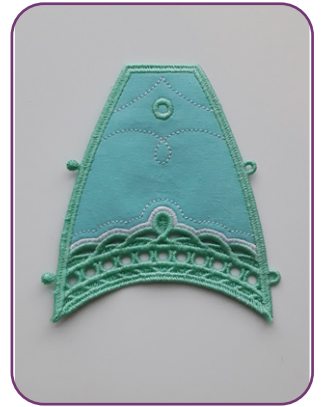

## Step 2

- Press each piece with a dry iron, right side down, on an OESD Perfect Embroidery Press Cloth.



## Step 3

- Place embroidered pieces onto cutting mat. Using the 3mm attachment with the punch tool, punch holes in the eyelets. Refer to the punch tool guides on page 18 for hole placement.





# ASSEMBLY



## Step 4

- Line up the pieces to sew as shown face up, alternating the blue and green sections and the Umbrella Top in the center.
- Load the sewing machine with matching thread in the top and bobbin. An open toe presser foot is helpful in this step.
- Stitch together using a multi-step zigzag stitch. Backstitch at the beginning and end to secure. Trim thread tails.

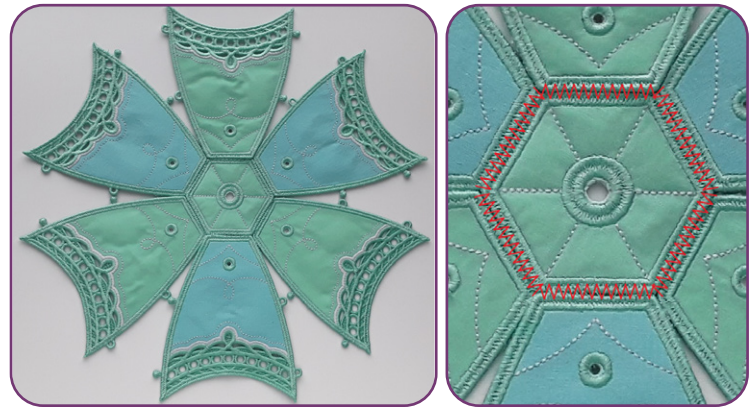

## Step 5

- Match the eyelets and buttonettes as shown on the Umbrella sections.
- Pull each buttonette through the corresponding eyelet, using button clips to temporarily hold them in place, as needed.

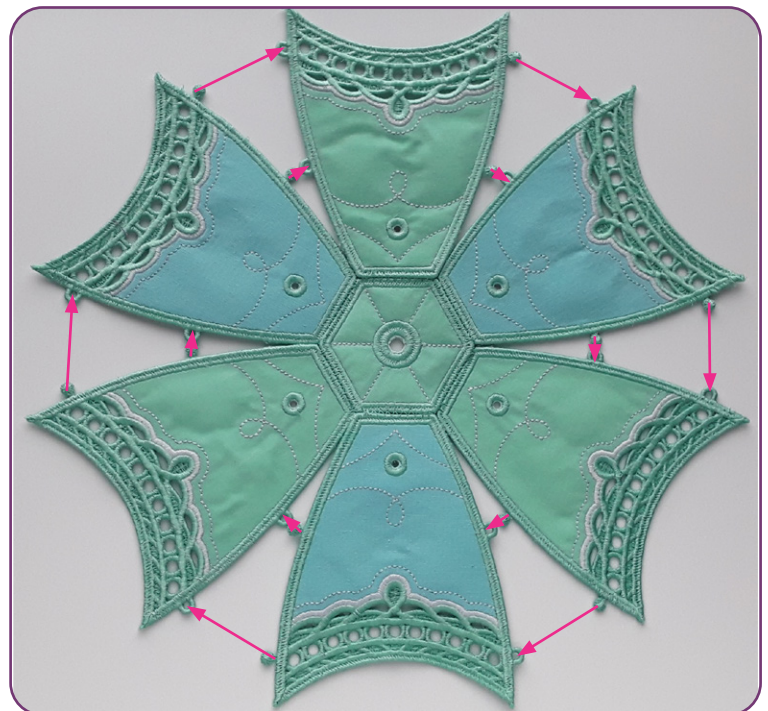

# ASSEMBLY



## Step 6

- Match the eyelets and buttonettes as shown for the Umbrella Brace.
- Bend the side flaps as needed.
- Pull each buttonette through the corresponding eyelet, using button clips to temporarily hold them in place, as needed.

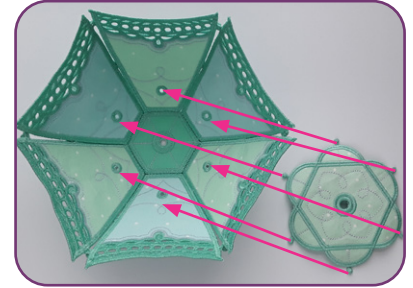

## Step 7

- Match the eyelets and buttonettes for the Umbrella Handle.
- Pull each buttonette through the corresponding eyelet, using button clips to temporarily hold them in place, as needed.



## Step 8

- Insert the 5/16" dowel into the hole of the Brace and through to the Umbrella Top.

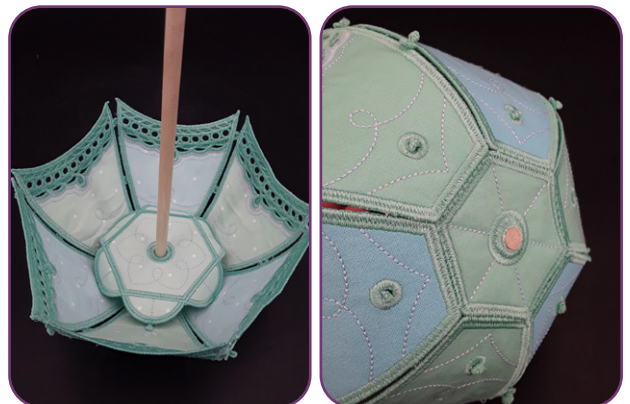

# ASSEMBLY



## Step

- Insert the opening of the handle on the other end of the dowel.



## Step 10

- The umbrella is complete. Enjoy.





# PUNCH TOOL GUIDES



51256-01

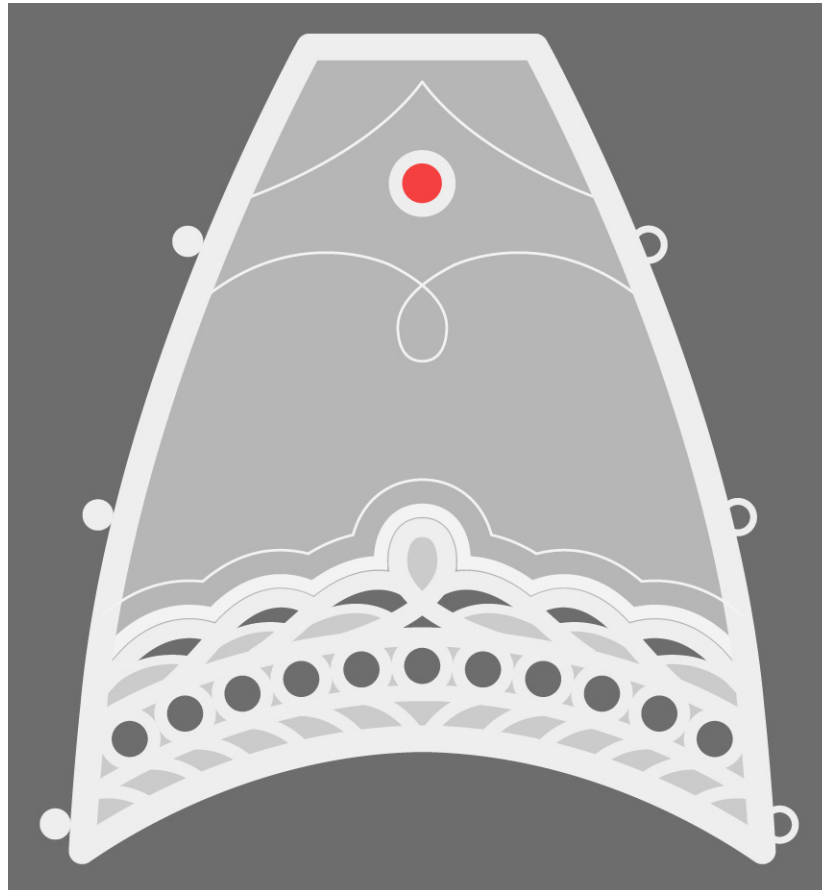

51256-04

-  = 2 MM
-  = 3 MM
-  = 4 MM

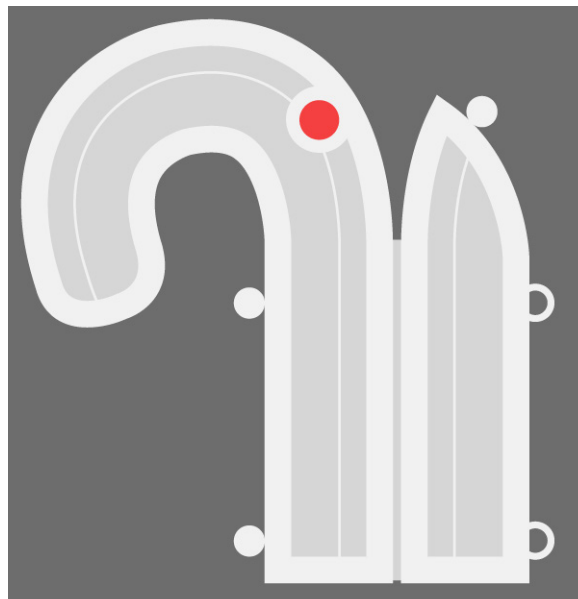

# PRINTING INSTRUCTIONS



## ATTENTION

When printing this document, any page scaling or page fitting options in your print dialog box must be turned OFF or set to NONE so that your files will print out at their actual size. Images not printed at actual size will not function as intended.

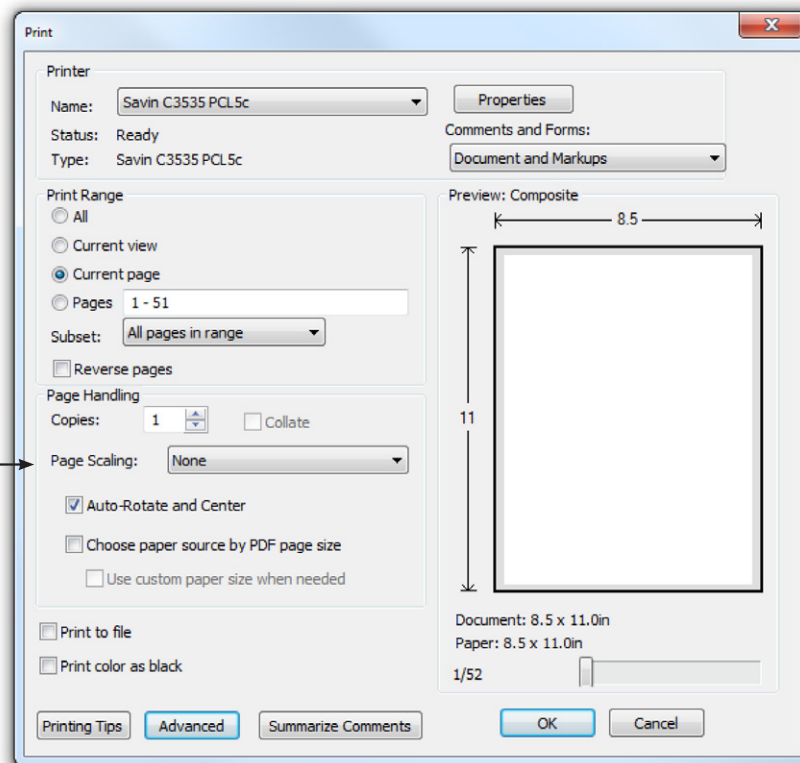

## TO SAVE PAPER

Only print the desired image by navigating to the image's page, go to File > Print and select "Current page" in the print dialog box. Repeat for each desired image.

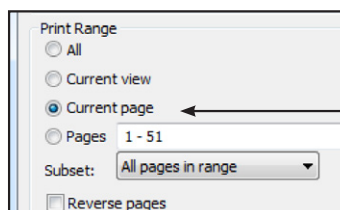

# APPLIQUE PATTERNS



Print at 100%. No scaling. This box measures 1" x 1". Use the box as an accuracy guide when printing templates.

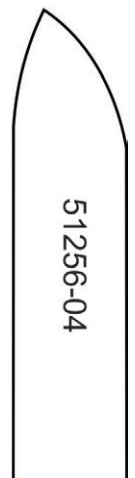
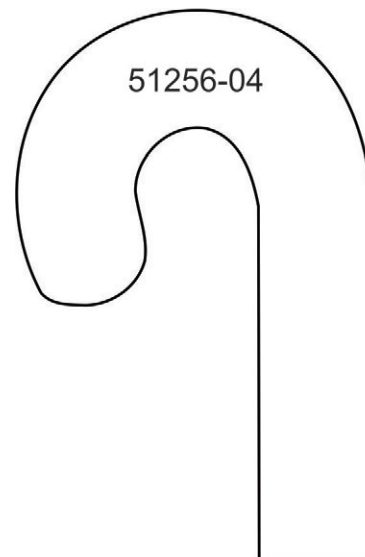
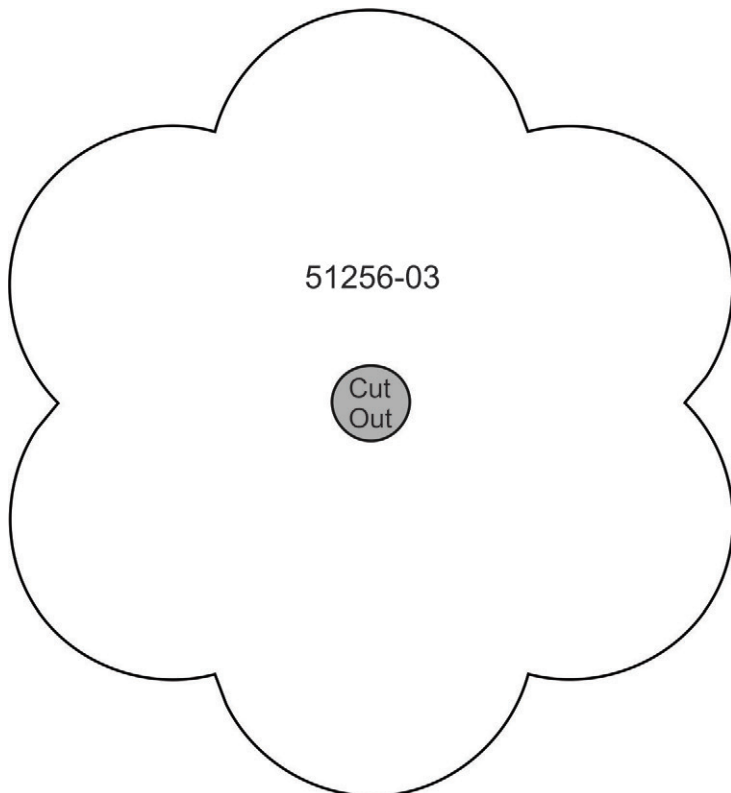
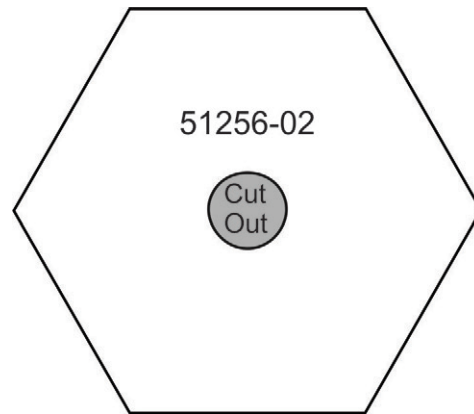
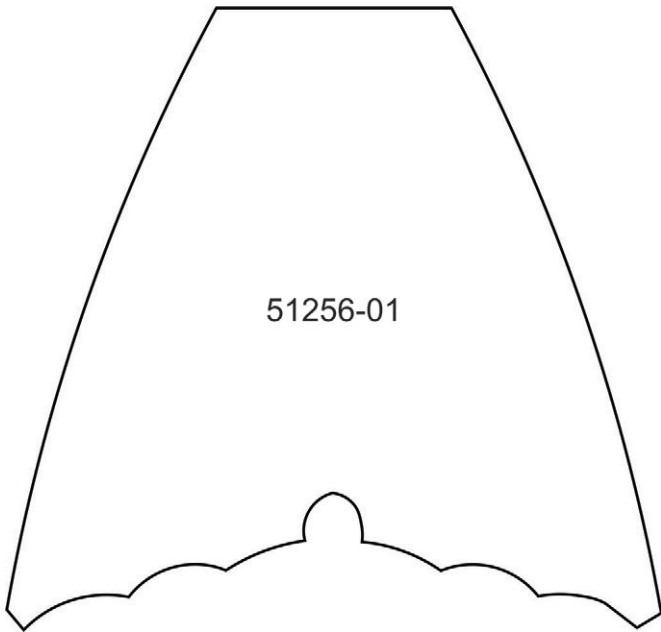



# MIRRORED PATTERNS



Print at 100%. No scaling. This box measures 1" x 1". Use the box as an accuracy guide when printing templates.

