



#51264  
26 DESIGNS



## FREESTANDING LIGHTED LETTERS

It is a violation of Copyright law to make and distribute copies of electronic designs or artwork.  
Electronic designs are licensed to the original purchaser for use at one location. ©2021 OESD, LLC. All rights reserved.

# MATERIALS



## Isacord Thread Colors

0108 Cobblestone  
0630 Buttercup  
1840 Corsage  
2550 Soft Pink  
4740 Aquamarine

**\*Project instructions included after design list**



# DESIGNS



Note: Some designs in this collection may have been created using unique special stitches and/or techniques. To preserve design integrity when rescaling or rotating designs in your software, always rescale or rotate designs using the handles directly on-screen.

## FABRIC REQUIRED



### 51264-01 A Square FSA

Size Inches:                      Size mm:                      Stitch Count:  
**6.19 X 6.34 in. 157.3 X 161.0 mm 15205 St.**

- 1. Fiber Form/Front & Back Black Fabric Placement Stitch.....0108
- 2. Cut Line and Tackdown.....0108
- 3. Gray Cover Stitch.....0108
- 4. Red Fabric Placement Stitch.....1840
- 5. Cut Line and Tackdown.....1840
- 6. Pink Cover Stitch.....1840

## FABRIC REQUIRED



### 51264-02 B Square FSA

Size Inches:                      Size mm:                      Stitch Count:  
**6.19 X 6.34 in. 157.3 X 161.0 mm 16903 St.**

- 1. Fiber Form/Front & Back Black Fabric Placement Stitch.....0108
- 2. Cut Line and Tackdown.....0108
- 3. Gray Cover Stitch.....0108
- 4. Pink Fabric Placement Stitch.....2550
- 5. Cut Line and Tackdown.....2550
- 6. Hot Pink Cover Stitch.....2550

# DESIGNS



Note: Some designs in this collection may have been created using unique special stitches and/or techniques. To preserve design integrity when rescaling or rotating designs in your software, always rescale or rotate designs using the handles directly on-screen.

## FABRIC REQUIRED



### 51264-03 C Square FSA

Size Inches:                      Size mm:                      Stitch Count:  
**6.19 X 6.34 in. 157.3 X 161.0 mm 14910 St.**

- 1. Fiber Form/Front & Back Black Fabric Placement Stitch.....0108
- 2. Cut Line and Tackdown.....0108
- 3. Gray Cover Stitch.....0108
- 4. Blue Fabric Placement Stitch.....4740
- 5. Cut Line and Tackdown.....4740
- 6. Blue Cover Stitch.....4740

## FABRIC REQUIRED



### 51264-04 D Square FSA

Size Inches:                      Size mm:                      Stitch Count:  
**6.19 X 6.34 in. 157.3 X 161.0 mm 15517 St.**

- 1. Fiber Form/Front & Back Black Fabric Placement Stitch.....0108
- 2. Cut Line and Tackdown.....0108
- 3. Gray Cover Stitch.....0108
- 4. Yellow Fabric Placement Stitch .....0630
- 5. Cut Line and Tackdown.....0630
- 6. Yellow Cover Stitch .....0630



# DESIGNS



Note: Some designs in this collection may have been created using unique special stitches and/or techniques. To preserve design integrity when rescaling or rotating designs in your software, always rescale or rotate designs using the handles directly on-screen.

## FABRIC REQUIRED

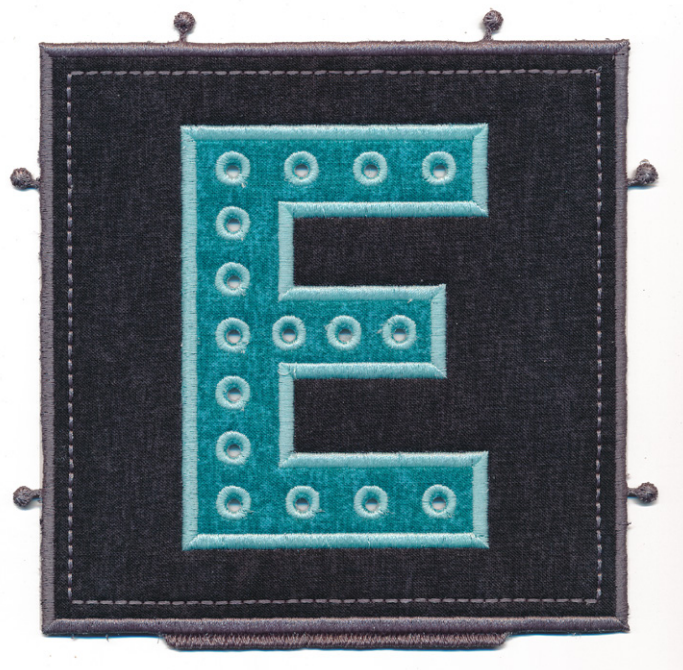

### 51264-05 E Square FSA

Size Inches:                      Size mm:                      Stitch Count:  
**6.19 X 6.34 in. 157.3 X 161.0 mm 15164 St.**

- 1. Fiber Form/Front & Back Black Fabric Placement Stitch.....0108
- 2. Cut Line and Tackdown.....0108
- 3. Gray Cover Stitch.....0108
- 4. Blue Fabric Placement Stitch.....4740
- 5. Cut Line and Tackdown.....4740
- 6. Blue Cover Stitch.....4740

## FABRIC REQUIRED



### 51264-06 F Square FSA

Size Inches:                      Size mm:                      Stitch Count:  
**6.19 X 6.34 in. 157.3 X 161.0 mm 13979 St.**

- 1. Fiber Form/Front & Back Black Fabric Placement Stitch.....0108
- 2. Cut Line and Tackdown.....0108
- 3. Gray Cover Stitch.....0108
- 4. Red Fabric Placement Stitch.....1840
- 5. Cut Line and Tackdown.....1840
- 6. Pink Cover Stitch.....1840

# DESIGNS



Note: Some designs in this collection may have been created using unique special stitches and/or techniques. To preserve design integrity when rescaling or rotating designs in your software, always rescale or rotate designs using the handles directly on-screen.

## FABRIC REQUIRED



### 51264-07 G Square FSA

Size Inches:                      Size mm:                      Stitch Count:  
**6.19 X 6.34 in. 157.3 X 161.0 mm 16338 St.**

- 1. Fiber Form/Front & Back Black Fabric Placement Stitch.....0108
- 2. Cut Line and Tackdown.....0108
- 3. Gray Cover Stitch.....0108
- 4. Yellow Fabric Placement Stitch .....0630
- 5. Cut Line and Tackdown.....0630
- 6. Yellow Cover Stitch .....0630

## FABRIC REQUIRED



### 51264-08 H Square FSA

Size Inches:                      Size mm:                      Stitch Count:  
**6.19 X 6.34 in. 157.3 X 161.0 mm 15344 St.**

- 1. Fiber Form/Front & Back Black Fabric Placement Stitch.....0108
- 2. Cut Line and Tackdown.....0108
- 3. Gray Cover Stitch.....0108
- 4. Pink Fabric Placement Stitch .....2550
- 5. Cut Line and Tackdown.....2550
- 6. Hot Pink Cover Stitch .....2550



# DESIGNS



Note: Some designs in this collection may have been created using unique special stitches and/or techniques. To preserve design integrity when rescaling or rotating designs in your software, always rescale or rotate designs using the handles directly on-screen.

## FABRIC REQUIRED



### 51264-09 I Square FSA

Size Inches:                      Size mm:                      Stitch Count:  
**6.19 X 6.34 in. 157.3 X 161.0 mm 14308 St.**

- 1. Fiber Form/Front & Back Black Fabric Placement Stitch.....0108
- 2. Cut Line and Tackdown.....0108
- 3. Gray Cover Stitch.....0108
- 4. Yellow Fabric Placement Stitch .....0630
- 5. Cut Line and Tackdown.....0630
- 6. Yellow Cover Stitch .....0630

## FABRIC REQUIRED



### 51264-10 J Square FSA

Size Inches:                      Size mm:                      Stitch Count:  
**6.19 X 6.34 in. 157.3 X 161.0 mm 13706 St.**

- 1. Fiber Form/Front & Back Black Fabric Placement Stitch.....0108
- 2. Cut Line and Tackdown.....0108
- 3. Gray Cover Stitch.....0108
- 4. Blue Fabric Placement Stitch.....4740
- 5. Cut Line and Tackdown.....4740
- 6. Blue Cover Stitch.....4740

# DESIGNS



Note: Some designs in this collection may have been created using unique special stitches and/or techniques. To preserve design integrity when rescaling or rotating designs in your software, always rescale or rotate designs using the handles directly on-screen.

## FABRIC REQUIRED



### 51264-11 K Square FSA

Size Inches:                      Size mm:                      Stitch Count:  
**6.19 X 6.34 in. 157.3 X 161.0 mm 15365 St.**

- 1. Fiber Form/Front & Back Black Fabric Placement Stitch.....0108
- 2. Cut Line and Tackdown.....0108
- 3. Gray Cover Stitch.....0108
- 4. Pink Fabric Placement Stitch.....2550
- 5. Cut Line and Tackdown.....2550
- 6. Hot Pink Cover Stitch.....2550

## FABRIC REQUIRED



### 51264-12 L Square FSA

Size Inches:                      Size mm:                      Stitch Count:  
**6.19 X 6.34 in. 157.3 X 161.0 mm 12330 St.**

- 1. Fiber Form/Front & Back Black Fabric Placement Stitch.....0108
- 2. Cut Line and Tackdown.....0108
- 3. Gray Cover Stitch.....0108
- 4. Red Fabric Placement Stitch.....1840
- 5. Cut Line and Tackdown.....1840
- 6. Pink Cover Stitch.....1840



# DESIGNS



Note: Some designs in this collection may have been created using unique special stitches and/or techniques. To preserve design integrity when rescaling or rotating designs in your software, always rescale or rotate designs using the handles directly on-screen.

## FABRIC REQUIRED

### 51264-13 M Square FSA

Size Inches:                      Size mm:                      Stitch Count:  
**6.19 X 6.34 in. 157.3 X 161.0 mm 17449 St.**

- 1. Fiber Form/Front & Back Black Fabric Placement Stitch.....0108
- 2. Cut Line and Tackdown.....0108
- 3. Gray Cover Stitch.....0108
- 4. Pink Fabric Placement Stitch.....2550
- 5. Cut Line and Tackdown.....2550
- 6. Hot Pink Cover Stitch .....2550



## FABRIC REQUIRED

### 51264-14 N Square FSA

Size Inches:                      Size mm:                      Stitch Count:  
**6.19 X 6.34 in. 157.3 X 161.0 mm 15951 St.**

- 1. Fiber Form/Front & Back Black Fabric Placement Stitch.....0108
- 2. Cut Line and Tackdown.....0108
- 3. Gray Cover Stitch.....0108
- 4. Yellow Fabric Placement Stitch .....0630
- 5. Cut Line and Tackdown.....0630
- 6. Yellow Cover Stitch .....0630



# DESIGNS



Note: Some designs in this collection may have been created using unique special stitches and/or techniques. To preserve design integrity when rescaling or rotating designs in your software, always rescale or rotate designs using the handles directly on-screen.

## FABRIC REQUIRED

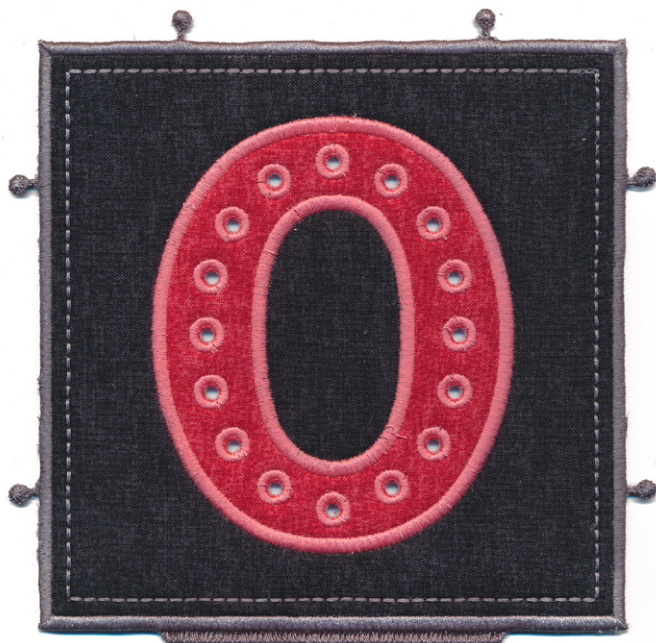

### 51264-15 O Square FSA

Size Inches:                      Size mm:                      Stitch Count:  
**6.19 X 6.34 in. 157.3 X 161.0 mm 14725 St.**

- 1. Fiber Form/Front & Back Black Fabric Placement Stitch.....0108
- 2. Cut Line and Tackdown.....0108
- 3. Gray Cover Stitch.....0108
- 4. Red Fabric Placement Stitch.....1840
- 5. Cut Line and Tackdown.....1840
- 6. Pink Cover Stitch.....1840

## FABRIC REQUIRED



### 51264-16 P Square FSA

Size Inches:                      Size mm:                      Stitch Count:  
**6.19 X 6.34 in. 157.3 X 161.0 mm 14810 St.**

- 1. Fiber Form/Front & Back Black Fabric Placement Stitch.....0108
- 2. Cut Line and Tackdown.....0108
- 3. Gray Cover Stitch.....0108
- 4. Blue Fabric Placement Stitch.....4740
- 5. Cut Line and Tackdown.....4740
- 6. Blue Cover Stitch.....4740



# DESIGNS



Note: Some designs in this collection may have been created using unique special stitches and/or techniques. To preserve design integrity when rescaling or rotating designs in your software, always rescale or rotate designs using the handles directly on-screen.

## FABRIC REQUIRED



### 51264-17 Q Square FSA

Size Inches:                      Size mm:                      Stitch Count:  
**6.19 X 6.34 in. 157.3 X 161.0 mm 15783 St.**

- 1. Fiber Form/Front & Back Black Fabric Placement Stitch.....0108
- 2. Cut Line and Tackdown.....0108
- 3. Gray Cover Stitch.....0108
- 4. Red Fabric Placement Stitch.....1840
- 5. Cut Line and Tackdown.....1840
- 6. Pink Cover Stitch.....1840

## FABRIC REQUIRED



### 51264-18 R Square FSA

Size Inches:                      Size mm:                      Stitch Count:  
**6.19 X 6.34 in. 157.3 X 161.0 mm 16295 St.**

- 1. Fiber Form/Front & Back Black Fabric Placement Stitch.....0108
- 2. Cut Line and Tackdown.....0108
- 3. Gray Cover Stitch.....0108
- 4. Blue Fabric Placement Stitch.....4740
- 5. Cut Line and Tackdown.....4740
- 6. Blue Cover Stitch.....4740

# DESIGNS



Note: Some designs in this collection may have been created using unique special stitches and/or techniques. To preserve design integrity when rescaling or rotating designs in your software, always rescale or rotate designs using the handles directly on-screen.

## FABRIC REQUIRED



### 51264-19 S Square FSA

Size Inches:                      Size mm:                      Stitch Count:  
**6.19 X 6.34 in. 157.3 X 161.0 mm 15490 St.**

- 1. Fiber Form/Front & Back Black Fabric Placement Stitch.....0108
- 2. Cut Line and Tackdown.....0108
- 3. Gray Cover Stitch.....0108
- 4. Pink Fabric Placement Stitch.....2550
- 5. Cut Line and Tackdown.....2550
- 6. Hot Pink Cover Stitch .....2550

## FABRIC REQUIRED



### 51264-20 T Square FSA

Size Inches:                      Size mm:                      Stitch Count:  
**6.19 X 6.34 in. 157.3 X 161.0 mm 12989 St.**

- 1. Fiber Form/Front & Back Black Fabric Placement Stitch.....0108
- 2. Cut Line and Tackdown.....0108
- 3. Gray Cover Stitch.....0108
- 4. Yellow Fabric Placement Stitch .....0630
- 5. Cut Line and Tackdown.....0630
- 6. Yellow Cover Stitch .....0630



# DESIGNS



Note: Some designs in this collection may have been created using unique special stitches and/or techniques. To preserve design integrity when rescaling or rotating designs in your software, always rescale or rotate designs using the handles directly on-screen.

## FABRIC REQUIRED



### 51264-21 U Square FSA

Size Inches:                      Size mm:                      Stitch Count:  
**6.19 X 6.34 in. 157.3 X 161.0 mm 14887 St.**

- 1. Fiber Form/Front & Back Black Fabric Placement Stitch.....0108
- 2. Cut Line and Tackdown.....0108
- 3. Gray Cover Stitch.....0108
- 4. Blue Fabric Placement Stitch.....4740
- 5. Cut Line and Tackdown.....4740
- 6. Blue Cover Stitch.....4740

## FABRIC REQUIRED



### 51264-22 V Square FSA

Size Inches:                      Size mm:                      Stitch Count:  
**6.19 X 6.34 in. 157.3 X 161.0 mm 13923 St.**

- 1. Fiber Form/Front & Back Black Fabric Placement Stitch.....0108
- 2. Cut Line and Tackdown.....0108
- 3. Gray Cover Stitch.....0108
- 4. Red Fabric Placement Stitch.....1840
- 5. Cut Line and Tackdown.....1840
- 6. Pink Cover Stitch.....1840

# DESIGNS



Note: Some designs in this collection may have been created using unique special stitches and/or techniques. To preserve design integrity when rescaling or rotating designs in your software, always rescale or rotate designs using the handles directly on-screen.

## FABRIC REQUIRED



### 51264-23 W Square FSA

Size Inches:                      Size mm:                      Stitch Count:  
**6.19 X 6.34 in. 157.3 X 161.0 mm 16777 St.**

- 1. Fiber Form/Front & Back Black Fabric Placement Stitch.....0108
- 2. Cut Line and Tackdown.....0108
- 3. Gray Cover Stitch.....0108
- 4. Yellow Fabric Placement Stitch .....0630
- 5. Cut Line and Tackdown.....0630
- 6. Yellow Cover Stitch .....0630

## FABRIC REQUIRED



### 51264-24 X Square FSA

Size Inches:                      Size mm:                      Stitch Count:  
**6.19 X 6.34 in. 157.3 X 161.0 mm 14435 St.**

- 1. Fiber Form/Front & Back Black Fabric Placement Stitch.....0108
- 2. Cut Line and Tackdown.....0108
- 3. Gray Cover Stitch.....0108
- 4. Blue Fabric Placement Stitch.....4740
- 5. Cut Line and Tackdown.....4740
- 6. Blue Cover Stitch.....4740



# DESIGNS



Note: Some designs in this collection may have been created using unique special stitches and/or techniques. To preserve design integrity when rescaling or rotating designs in your software, always rescale or rotate designs using the handles directly on-screen.

## FABRIC REQUIRED



### 51264-25 Y Square FSA

Size Inches:                      Size mm:                      Stitch Count:  
**6.19 X 6.34 in. 157.3 X 161.0 mm 12932 St.**

- 1. Fiber Form/Front & Back Black Fabric Placement Stitch.....0108
- 2. Cut Line and Tackdown.....0108
- 3. Gray Cover Stitch.....0108
- 4. Yellow Fabric Placement Stitch .....0630
- 5. Cut Line and Tackdown.....0630
- 6. Yellow Cover Stitch .....0630

## FABRIC REQUIRED



### 51264-26 Z Square FSA

Size Inches:                      Size mm:                      Stitch Count:  
**6.19 X 6.34 in. 157.3 X 161.0 mm 14925 St.**

- 1. Fiber Form/Front & Back Black Fabric Placement Stitch.....0108
- 2. Cut Line and Tackdown.....0108
- 3. Gray Cover Stitch.....0108
- 4. Pink Fabric Placement Stitch .....2550
- 5. Cut Line and Tackdown.....2550
- 6. Hot Pink Cover Stitch .....2550

# DESIGNS



Note: Some designs in this collection may have been created using unique special stitches and/or techniques. To preserve design integrity when rescaling or rotating designs in your software, always rescale or rotate designs using the handles directly on-screen.

## FABRIC REQUIRED

### 51264-27 Frame Parts 1 FSA

Size Inches:                      Size mm:                      Stitch Count:  
**6.52 X 5.71 in. 165.7 X 145.1 mm 10341 St.**



- 1. Fiber Form/Front & Back Gray Fabric Placement Stitch.....0108
- 2. Cut Line and Tackdown.....0108
- 3. Gray Cover Stitch.....0108

## FABRIC REQUIRED

### 51264-28 Frame Parts 2 FSA

Size Inches:                      Size mm:                      Stitch Count:  
**5.71 X 4.81 in. 145.1 X 122.2 mm 8467 St.**

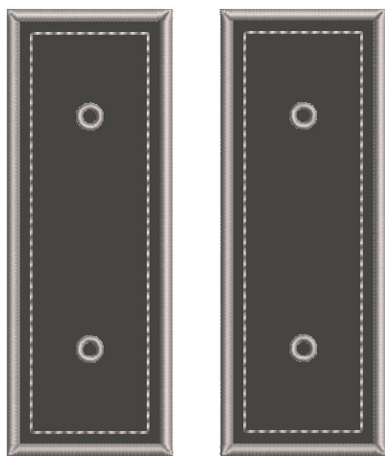

- 1. Fiber Form/Front & Back Gray Fabric Placement Stitch.....0108
- 2. Cut Line and Tackdown.....0108
- 3. Gray Cover Stitch.....0108



# MATERIALS



## Stabilizer

- OESD AquaMesh
- OESD BadgeMaster
- OESD Fusible Woven
- OESD Fiber Form
- Applique Fuse and Fix

## Notions & Tools

- Pixie Lights
- 505 Temporary Spray Adhesive
- OESD Alligator Clamps
- OESD Button Clips
- OESD Expert Embroidery Tape TearAway
- OESD Expert Embroidery Tape WashAway
- OESD Perfect Punch Tool
- OESD Perfect Embroidery Press Cloth
- Craft knife
- Organ Needle Embroidery Sharp 75/11

## Isacord Thread Colors

- As per thread chart
- Match bobbin thread to top thread

# MATERIALS



## Fabric/Textiles

	Black Fabric (background fabric)	Gray Fabric (Frame)	Letter Applique (Yellow, Blue, Red, Pink)
Cut Size	(2) 7" x 7"	51264-27 - (2) 7" x 8" 51264-28 - (2) 7" x 6"	(1) 6" x 6"
Fiber Form	(1) 7" x 7"	51264-27 - (1) 7" x 8" 51264-28 - (1) 7" x 6"	

**Note: Fabric sizes are estimates and may result in overage.**

## Stitch Outs

Each Letter will consist of three files. Two frame files and one letter file.

- Requires 1 - 51264-01 through 51264-26
- Requires 1 - 51264-27
- Requires 1 - 51264-28



# EMBROIDERY



## Note

- The applique instructions included in the design pack are general instructions for the collection. For demonstration purposes, a sample design that best represents the entire collection is shown. Example design is 51264-01. Fabric and thread requirements will vary by design, but the general technique will be the same.
- All designs are stitched with matching thread in the top and bobbin.
- Note: Some thread colors in instructions have been changed or digitally enhanced for better visibility.

## Step 1

- The project includes freestanding applique designs.
- All applique designs are stitched the same as shown in the instructions.
- Hoop one layer of AquaMesh and one layer of BadgeMaster for all designs.



## Step 2

- Prep the wrong side of the background and letter applique fabrics with one layer of Fusible Woven.



# EMBROIDERY



## Step 3

- Cut the prepared applique fabrics  $\frac{1}{4}$ " -  $\frac{1}{2}$ " larger than the templates located at the end of the instructions.
- Print the mirrored version of the templates (100% or 1:1 ratio) onto the paper side of Applique Fuse and Fix. Roughly cut approximately  $\frac{1}{4}$ " -  $\frac{1}{2}$ " outside the printed applique templates.



## Step 4

- Fuse the template to the back of the Fiber Form paper side up. Hold the iron on the template for 10-15 seconds for a secure fuse.

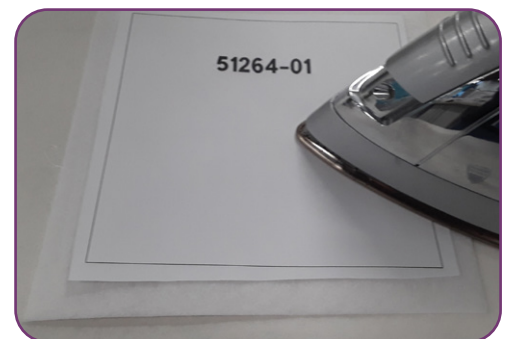

## Step 5

- Cut the Fiber Form out on the outer edge of the black outline and set aside.

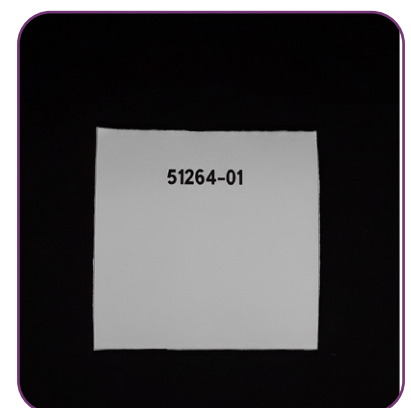



# EMBROIDERY



## Step 6

- Load selected design into the machine.
- Design in the example is 51264-01.
- Thread the machine per the thread chart.
- Stitch Machine Step 1, Fiber Form/Front and Back Black Fabric Placement Stitch.

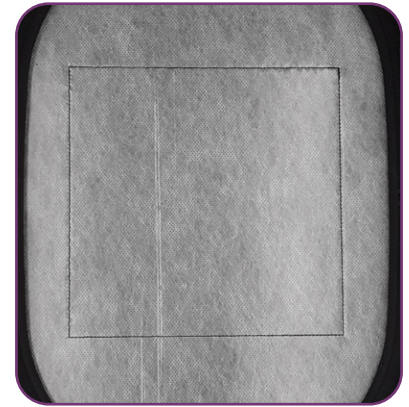

## Step 7

- Remove the hoop from the machine, but NOT the project from the hoop. Lay the hoop on a flat surface.
- Remove the paper from the back of the Fiber Form to expose the sticky surface.
- Position it in the placement stitch, matching the cut edges with the stitching.
- Finger press to secure.

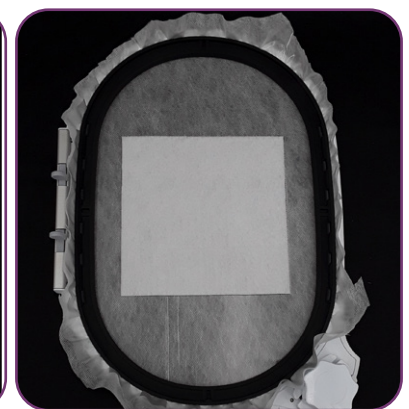
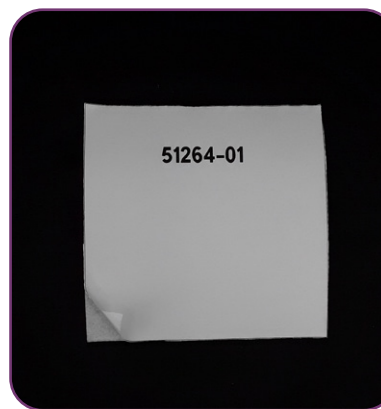

# EMBROIDERY



## Step 8

- Cover the front placement line and Fiber Form completely with one of the prepared background fabrics.
- Tape in place to secure.

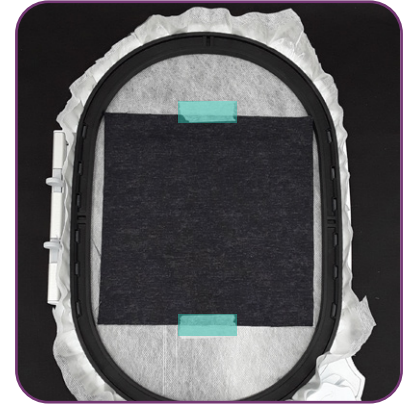

## Step 9

- Turn the hoop over and place the other black background fabric right side up covering the placement stitch.
- Carefully tape to secure. Avoid pushing too hard on the stabilizer to prevent it from dislodging from the hoop.



## Step 10

- Return the hoop to the machine.
- Stitch Machine Step 2, Cut Line and Tackdown.

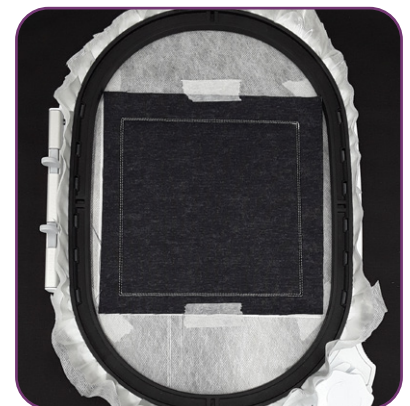



# EMBROIDERY



## Step 11

- Remove the hoop from the machine, but NOT the project from the hoop.
- Trim the excess fabric as close to the tackdown stitching as possible. If the outermost stitches are cut, the inner stitches will still hold the applique in place.
- Tip: If the AquaMesh is cut or a hole is created while trimming the fabric, simply use OESD Expert Embroidery Tape WashAway or AquaMesh Plus as a patch.

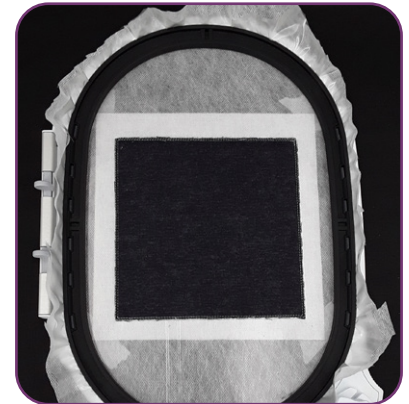

## Step 12

- Turn the hoop over.
- Trim the excess fabric as close to the tackdown stitching as possible. If the outermost stitches are cut, the inner stitches will still hold the applique in place.



## Step 13

- Return the hoop to the machine.
- Stitch Machine Step 3, Gray Cover Stitch.

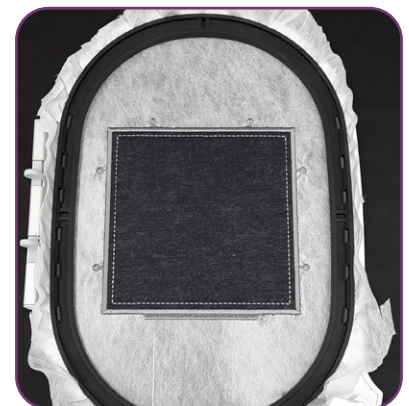

# EMBROIDERY



## Step 14

- Stitch Machine Step 4, Red Fabric Placement Stitch.

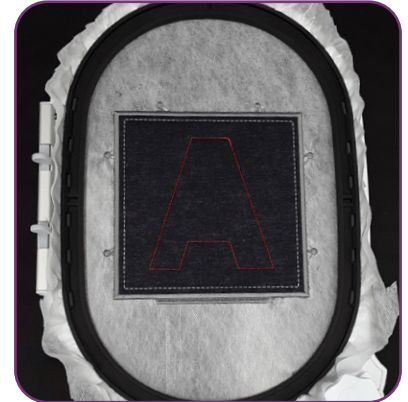

## Step 15

- Remove the hoop from the machine, but NOT the project from the hoop.
- Cover the placement line completely with the prepared letter applique fabric.
- Tape in place to secure.

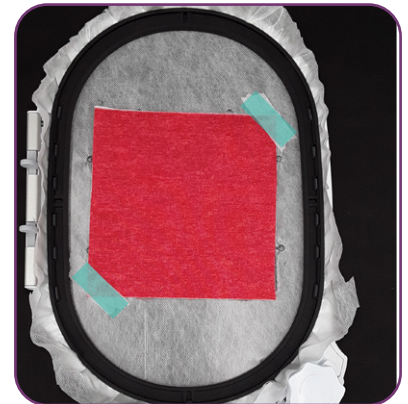

## Step 16

- Return the hoop to the machine.
- Stitch Machine Step 5, Cut Line and Tackdown.





# EMBROIDERY



## Step 17

- Remove the hoop from the machine, but NOT the project from the hoop.
- Trim the excess fabric as close to the tackdown stitching as possible. If the outermost stitches are cut, the inner stitches will still hold the applique in place.



## Step 18

- Return the hoop to the machine.
- Stitch Machine Step 6, Pink Cover Stitch.

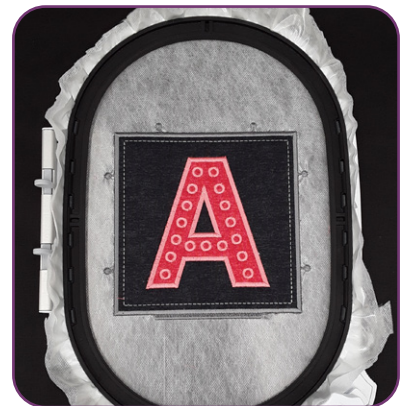

## Step 19

- When the design is complete, remove the project from the hoop and trim the stabilizer 1/4" - 1/2" outside the design.



# ASSEMBLY



## Step 1

- Rinse each piece in warm running water until the design is only slightly sticky.
- Lay face down on a non-stick surface to dry. Parchment paper or a cooling rack work well. This prevents the piece from curling.



## Step 2

- Press each piece, right side down, on a Perfect Embroidery Press Cloth.

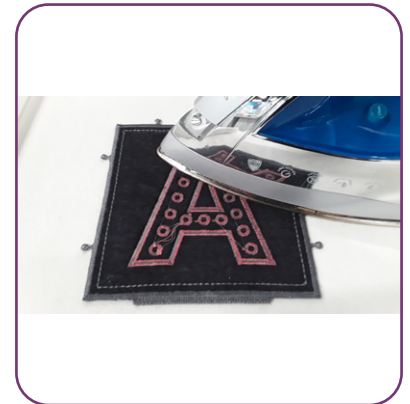

## Step 3

- Before assembly, use a utility knife to cut through all the layers of the tab entry, on page 27. Take care to not cut the satin stitching. See cutting tool guide following the instructions for punch tool and craft knife guidelines.





# ASSEMBLY



## Step 4

- Using OESD Punch Tool and 3mm attachment, punch holes in the eyelets indicated in the photo.

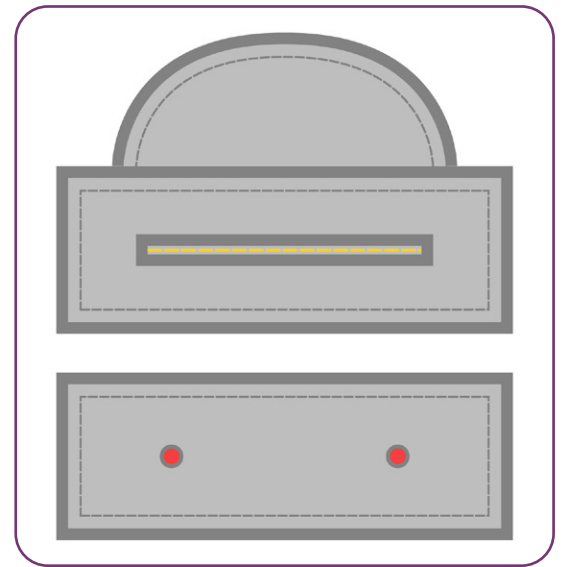

## Step 5

- Line up the 3 frame side pieces 51264-28 and 51264-27 (only the frame piece) to connect.
- Load the sewing machine with matching thread in the top and bobbin. An open toe or edge stitch foot is helpful.
- Stitch together using a multi-step zigzag stitch 3.6mm width 1.50 length (also known as a serpentine stitch). Back stitch at the beginning and end to secure. Trim thread tails.

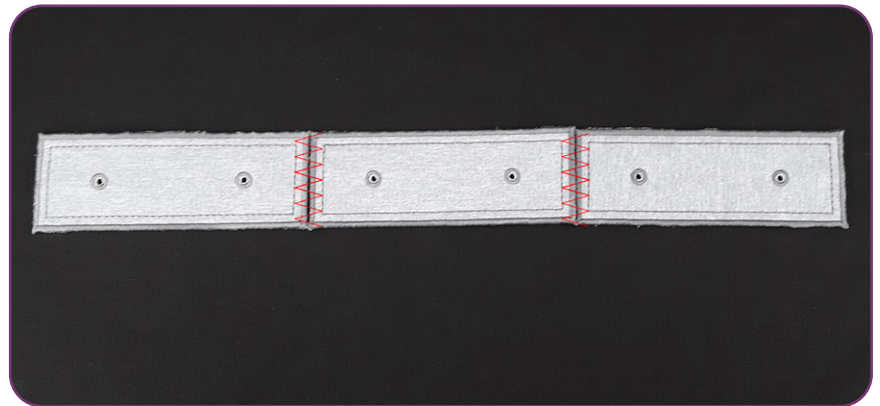

# ASSEMBLY



## Step 6

- Line up the frame base and side pieces to connect 51264-27.
- Stitch together using a multi-step zigzag stitch 3.6mm width 1.50 length (also known as a serpentine stitch). Back stitch at the beginning and end to secure. Trim thread tails.

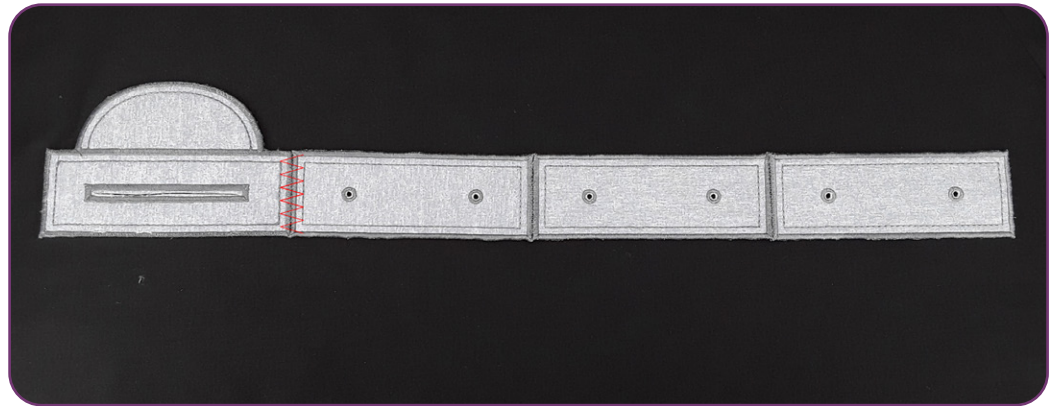

## Step 7

- Fold the frame side over to connect to the other side of the frame base.
- Stitch together using a multi-step zigzag stitch 3.6mm width 1.50 length (also known as a serpentine stitch). Back stitch at the beginning and end to secure. Trim thread tails.





# ASSEMBLY



## Step 8

- Match the eyelets of the frame to the buttonettes on the letter. Pull each buttonette through the corresponding eyelet, using button clips to temporarily hold them in place, as needed.
- Insert the tab into the corresponding slot.

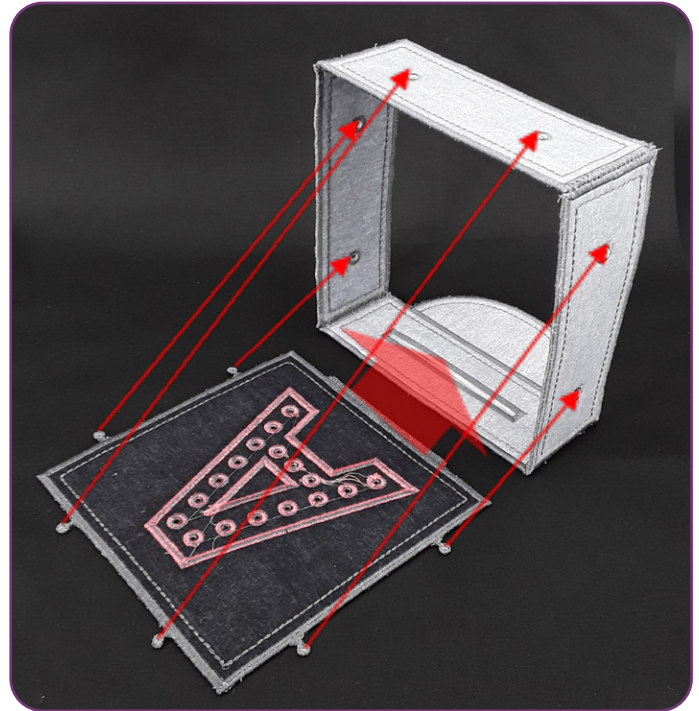

## Step 9

- Add pixie lights to the designated holes to create a glow.
- Note: Not all letters will use every available pixie light.



# PUNCH TOOL GUIDES



51264-27

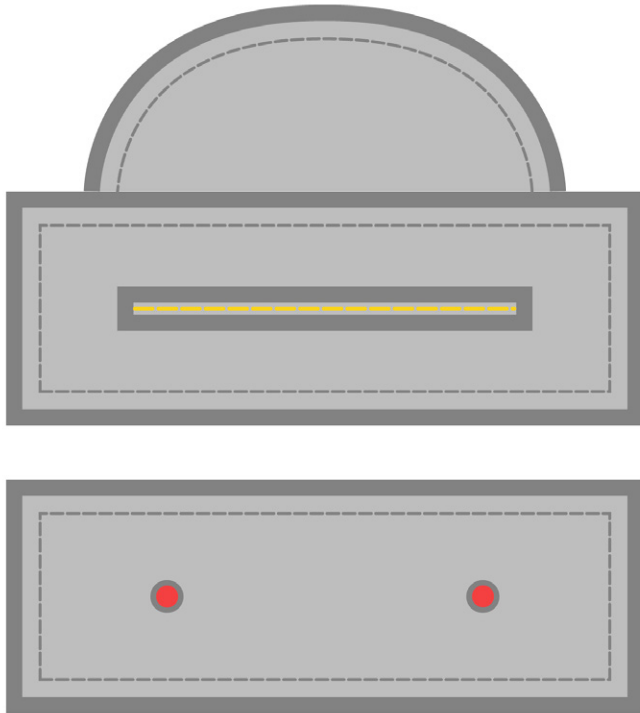

51264-28

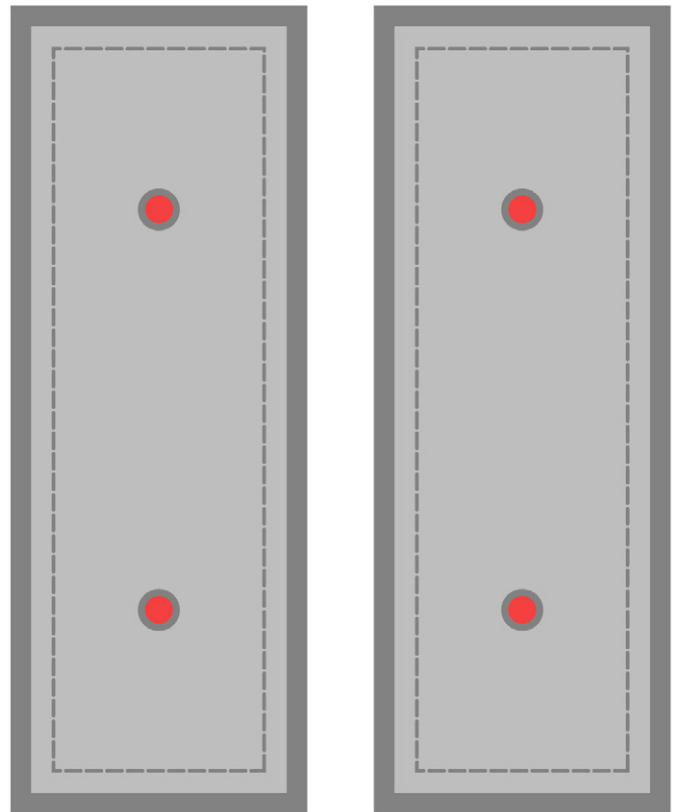

-  = 2 MM
-  = 3 MM
-  = 4 MM

CRAFT KNIFE





# PRINTING INSTRUCTIONS



## ATTENTION

When printing this document, any page scaling or page fitting options in your print dialog box must be turned OFF or set to NONE so that your files will print out at their actual size. Images not printed at actual size will not function as intended.

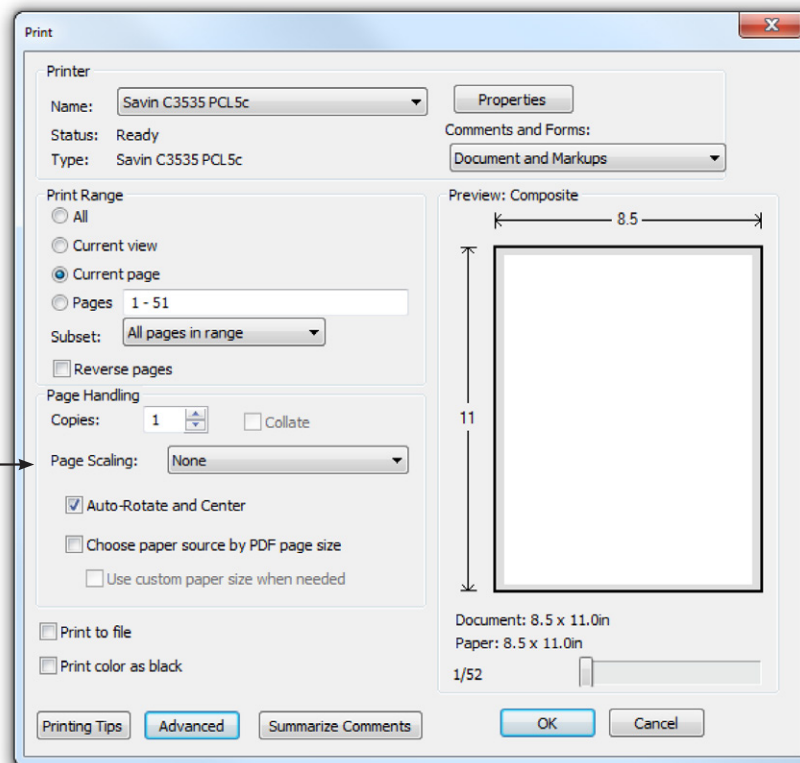

## TO SAVE PAPER

Only print the desired image by navigating to the image's page, go to File > Print and select "Current page" in the print dialog box. Repeat for each desired image.

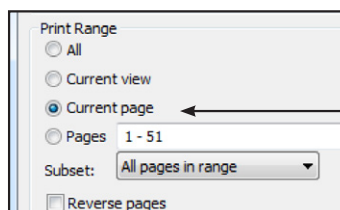

# APPLIQUE PATTERNS



Print at 100%. No scaling. This box measures 1" x 1". Use the box as an accuracy guide when printing templates.

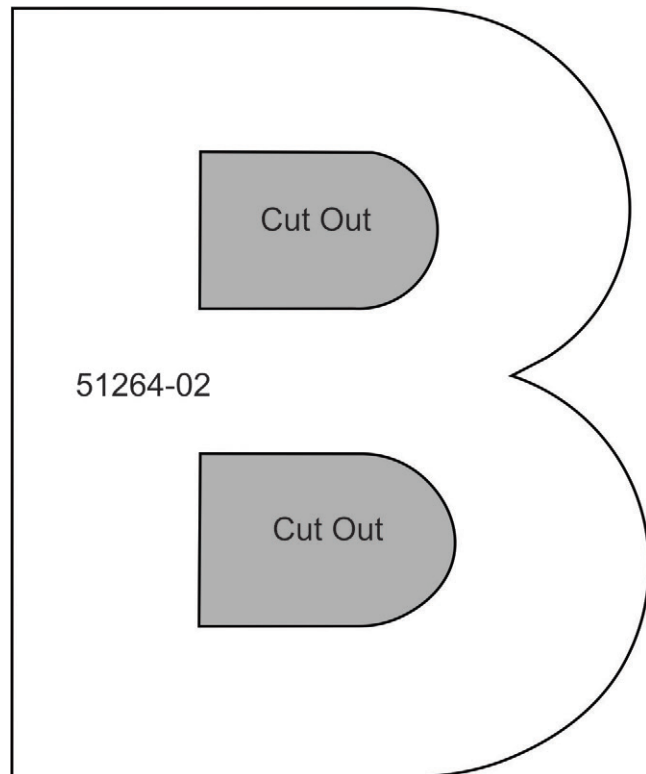
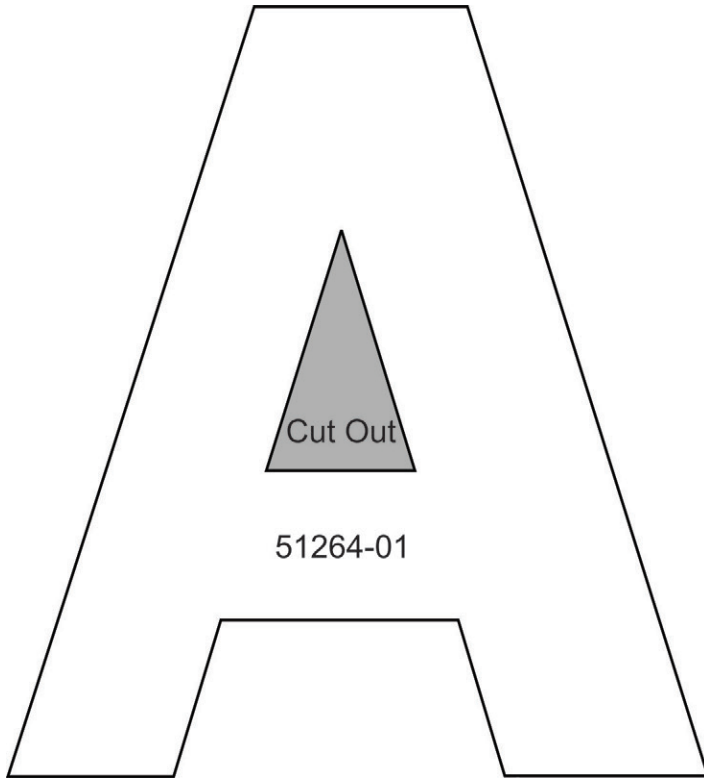



# APPLIQUE PATTERNS



Print at 100%. No scaling. This box measures 1" x 1". Use the box as an accuracy guide when printing templates.

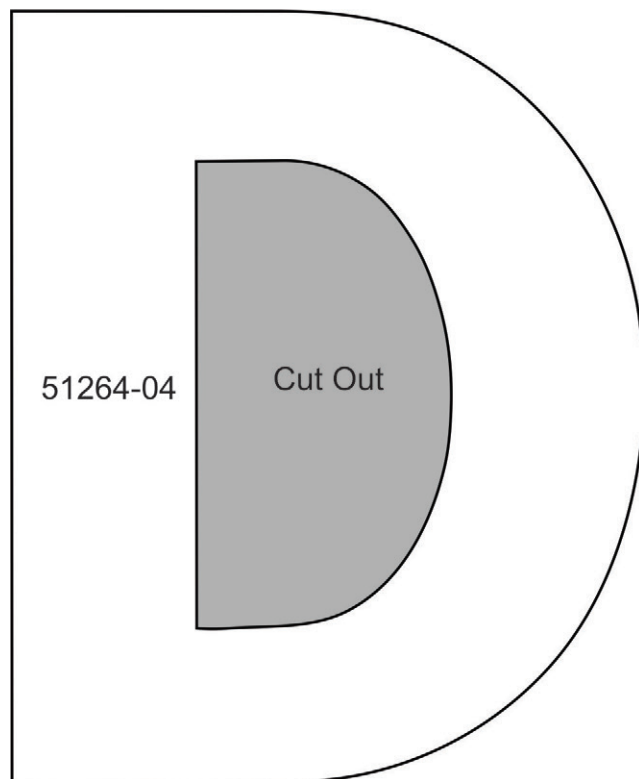
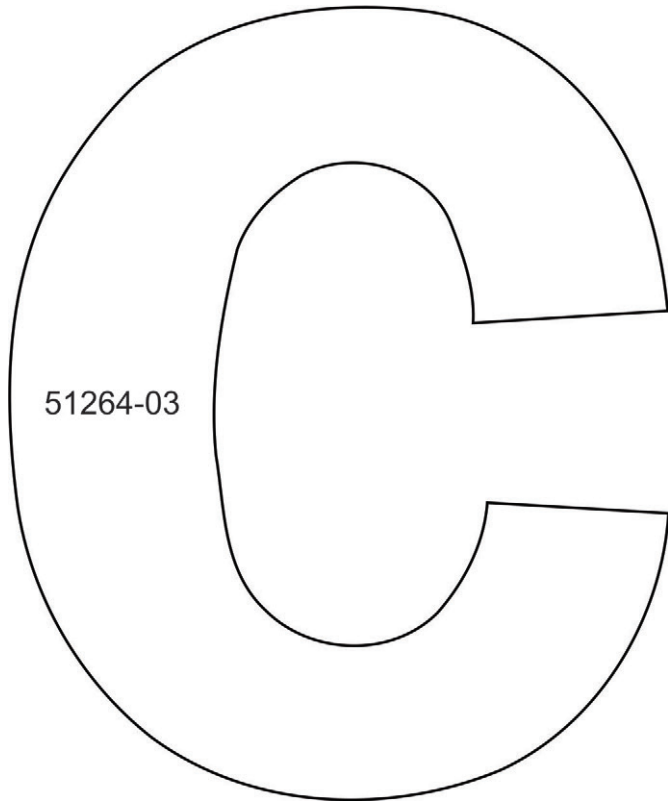

# APPLIQUE PATTERNS

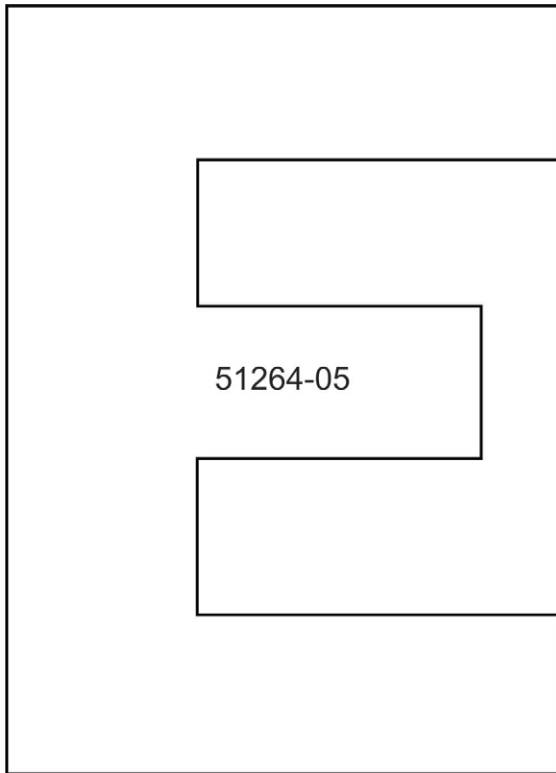

Print at 100%. No scaling. This box measures 1" x 1". Use the box as an accuracy guide when printing templates.

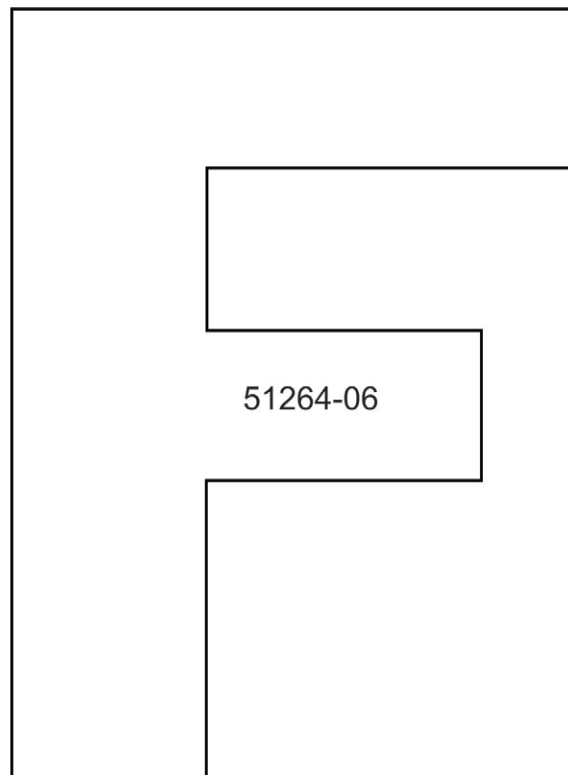



# APPLIQUE PATTERNS



Print at 100%. No scaling. This box measures 1" x 1". Use the box as an accuracy guide when printing templates.

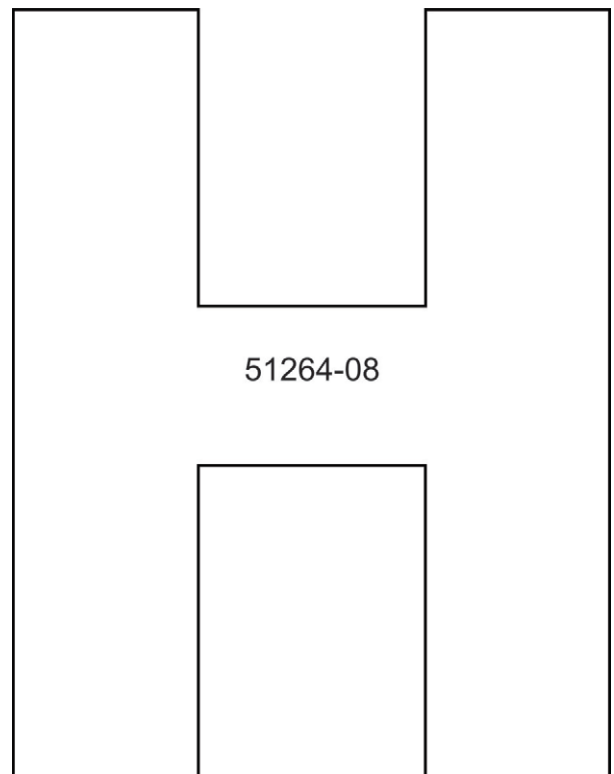
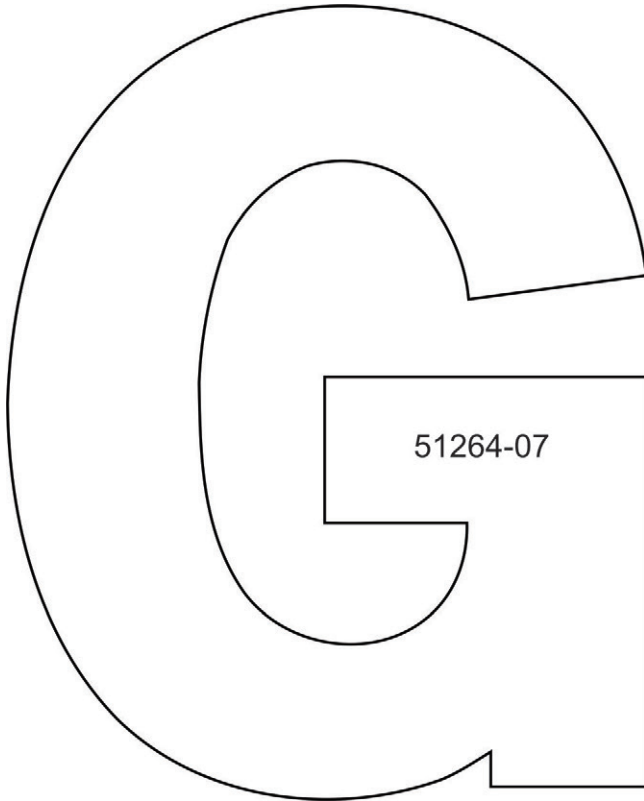

# APPLIQUE PATTERNS



Print at 100%. No scaling. This box measures 1" x 1". Use the box as an accuracy guide when printing templates.

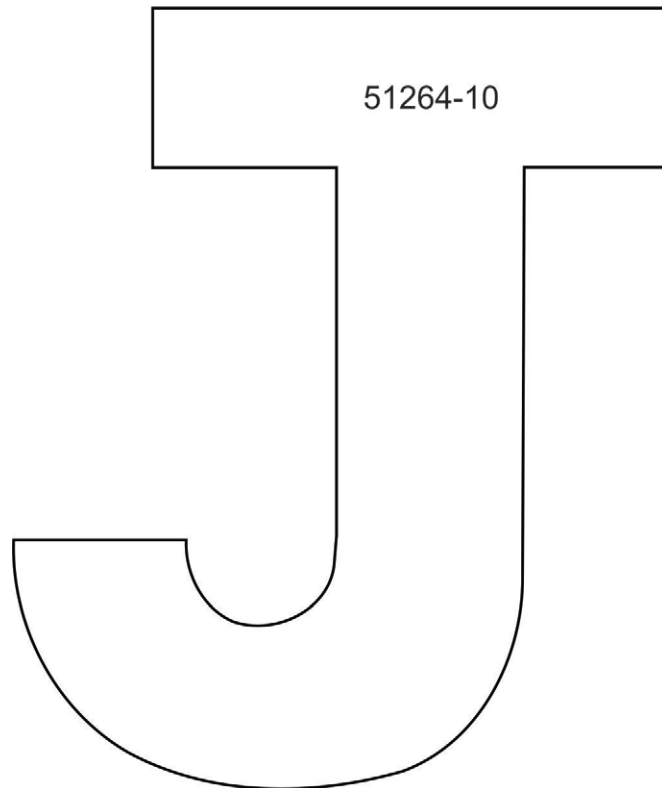
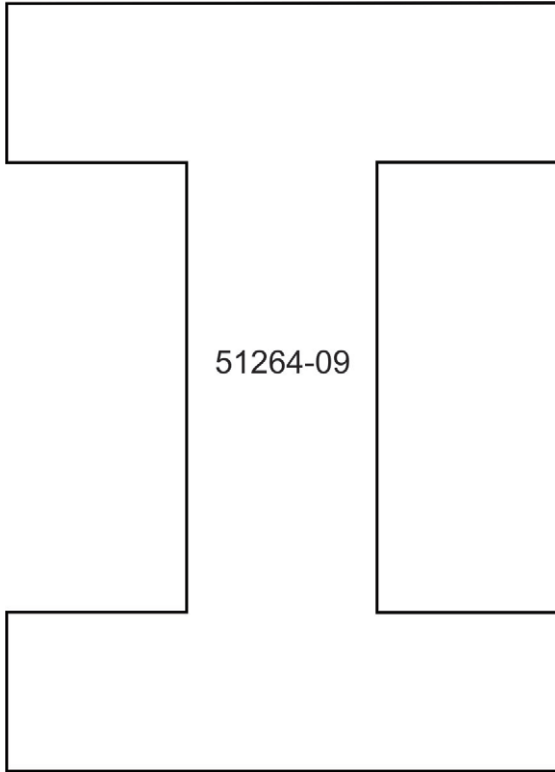

# APPLIQUE PATTERNS



Print at 100%. No scaling. This box measures 1" x 1". Use the box as an accuracy guide when printing templates.

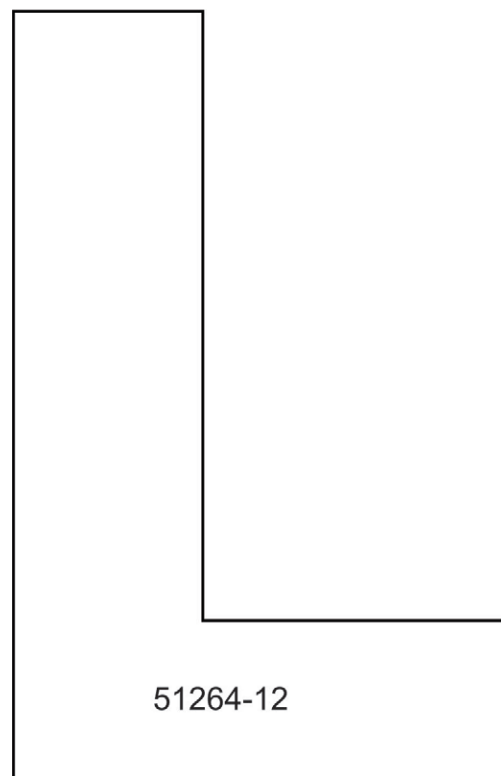
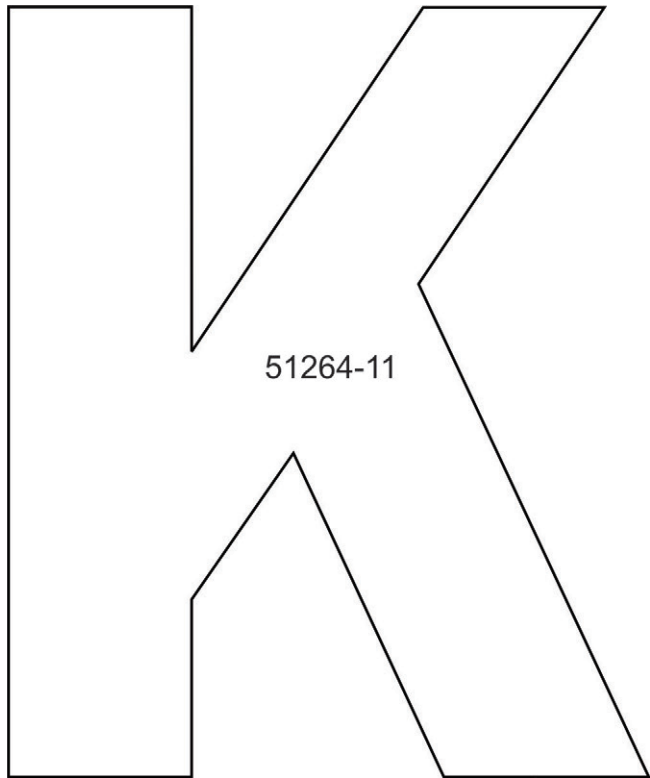



# APPLIQUE PATTERNS



Print at 100%. No scaling. This box measures 1" x 1". Use the box as an accuracy guide when printing templates.

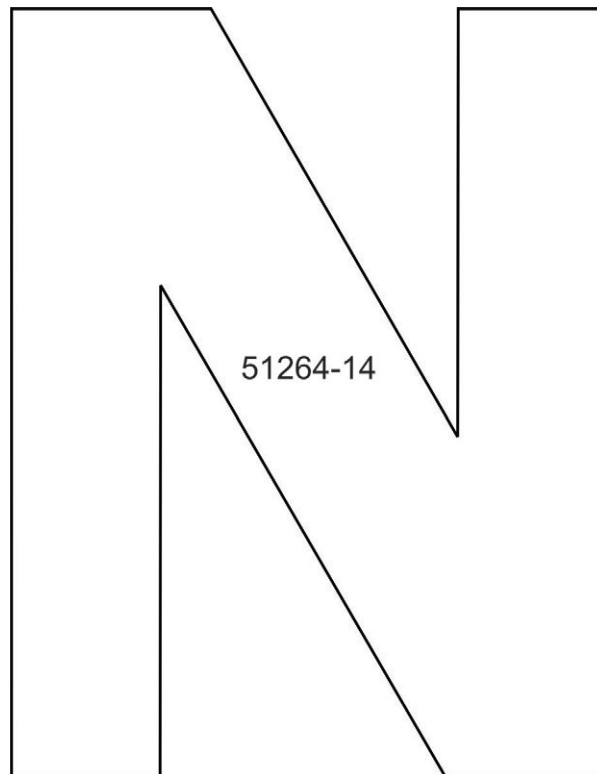
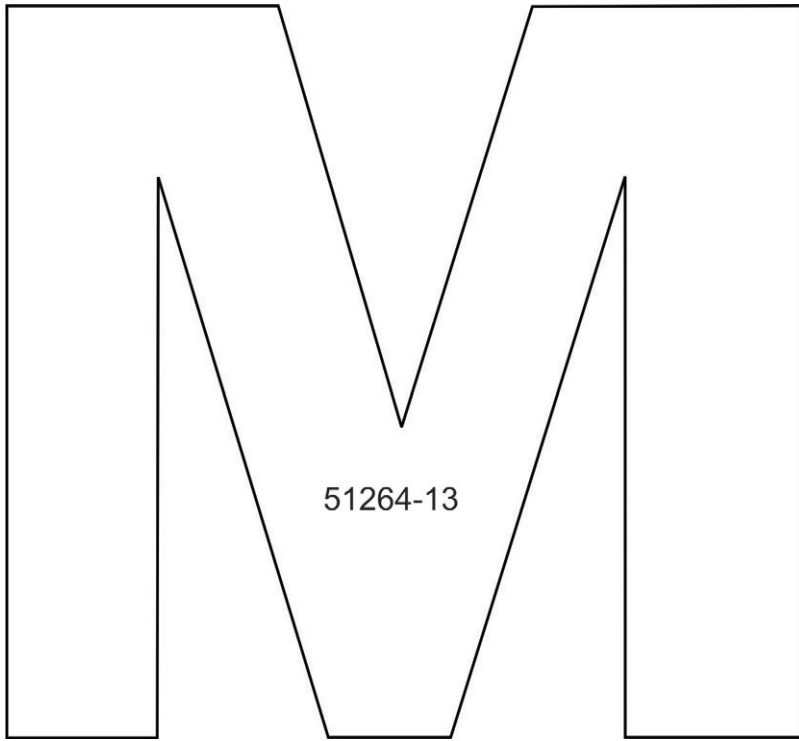

# APPLIQUE PATTERNS



Print at 100%. No scaling. This box measures 1" x 1". Use the box as an accuracy guide when printing templates.

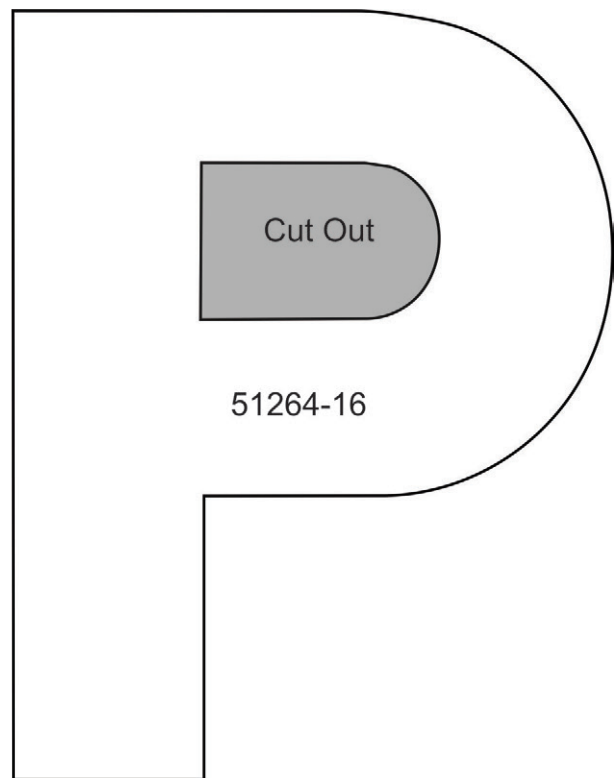
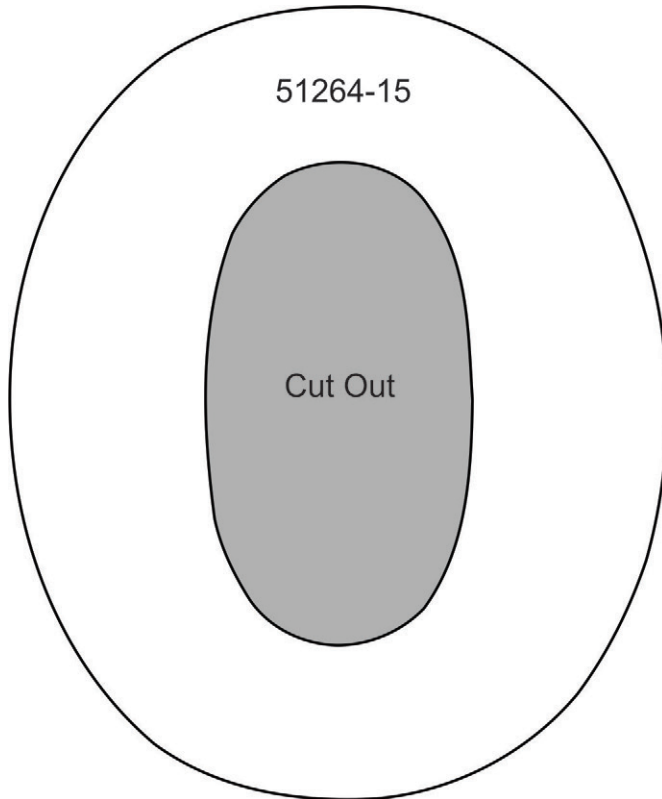

# APPLIQUE PATTERNS



Print at 100%. No scaling. This box measures 1" x 1". Use the box as an accuracy guide when printing templates.

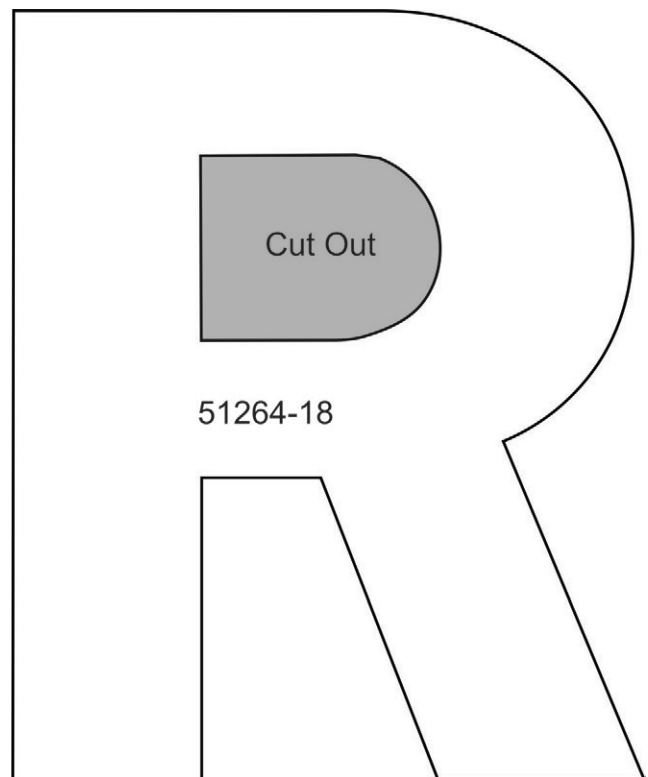
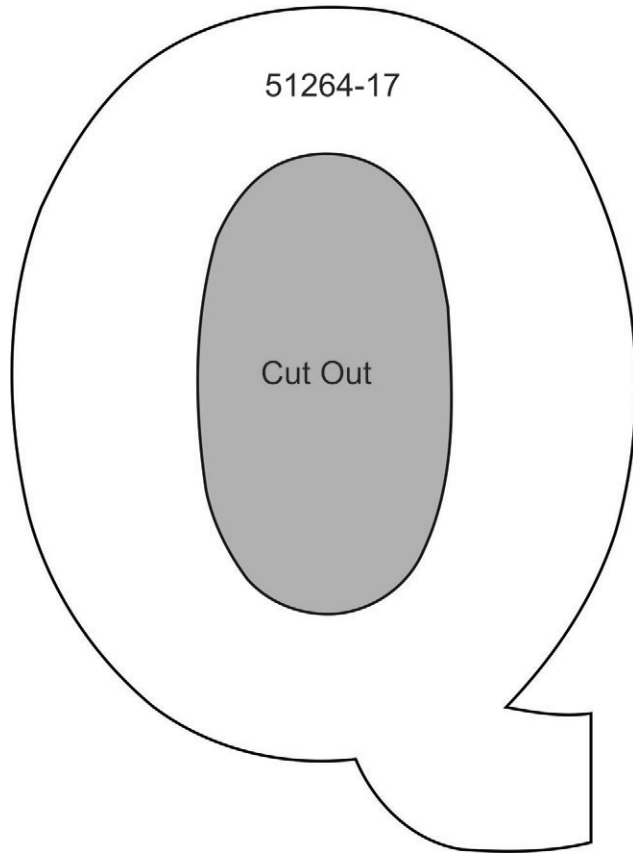



# APPLIQUE PATTERNS



Print at 100%. No scaling. This box measures 1" x 1". Use the box as an accuracy guide when printing templates.

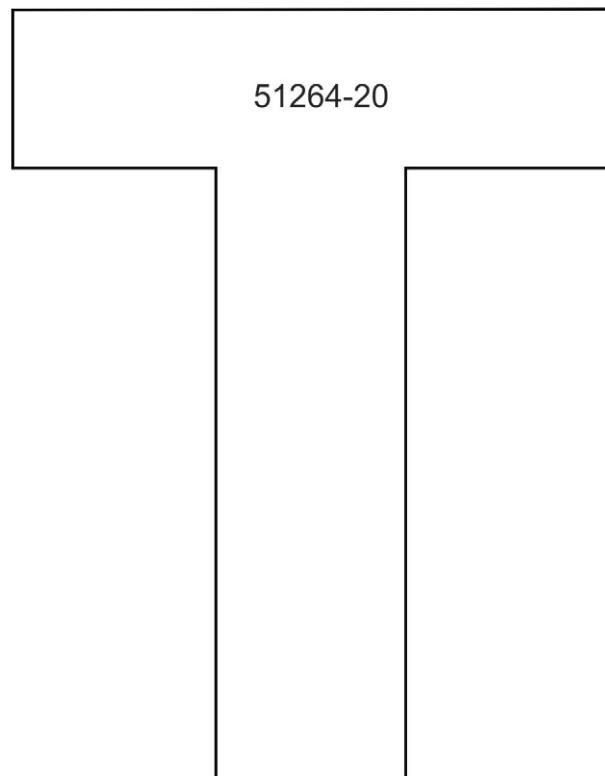
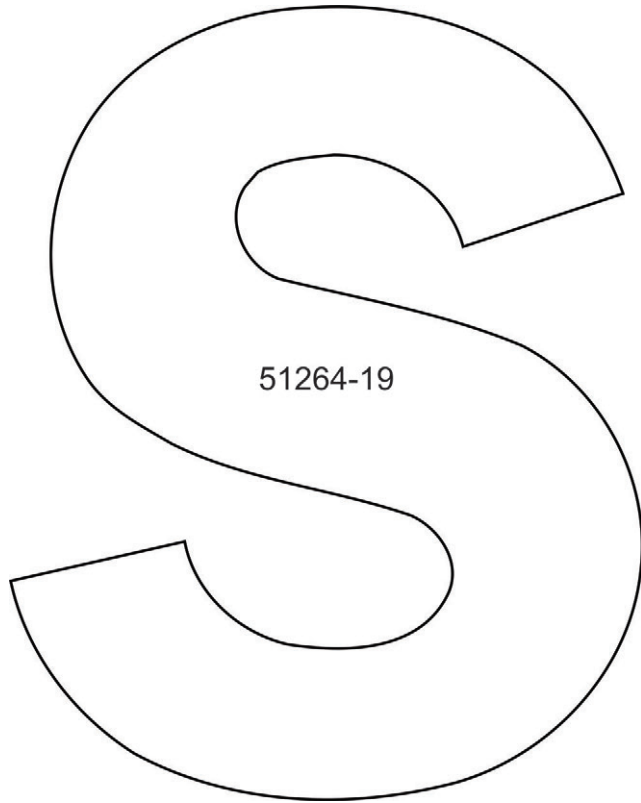

# APPLIQUE PATTERNS

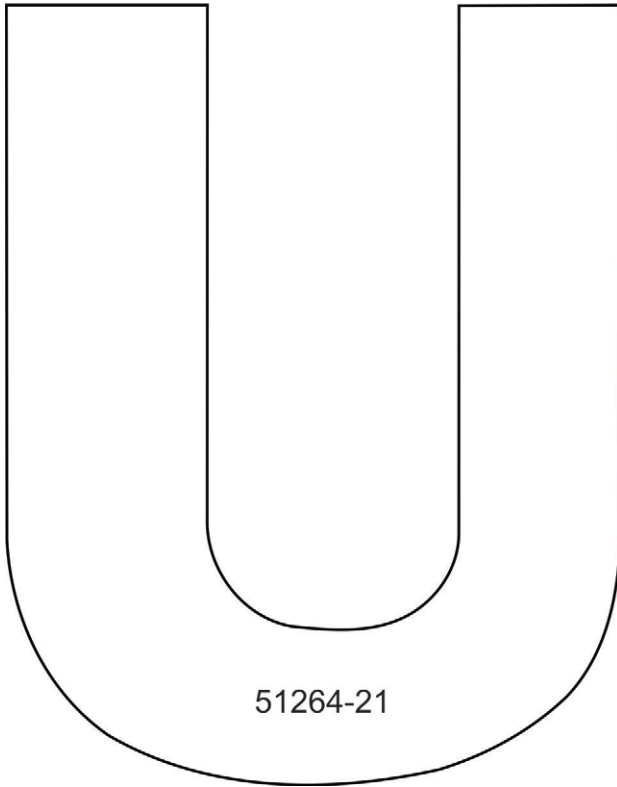

51264-21

Print at 100%. No scaling. This box measures 1" x 1". Use the box as an accuracy guide when printing templates.

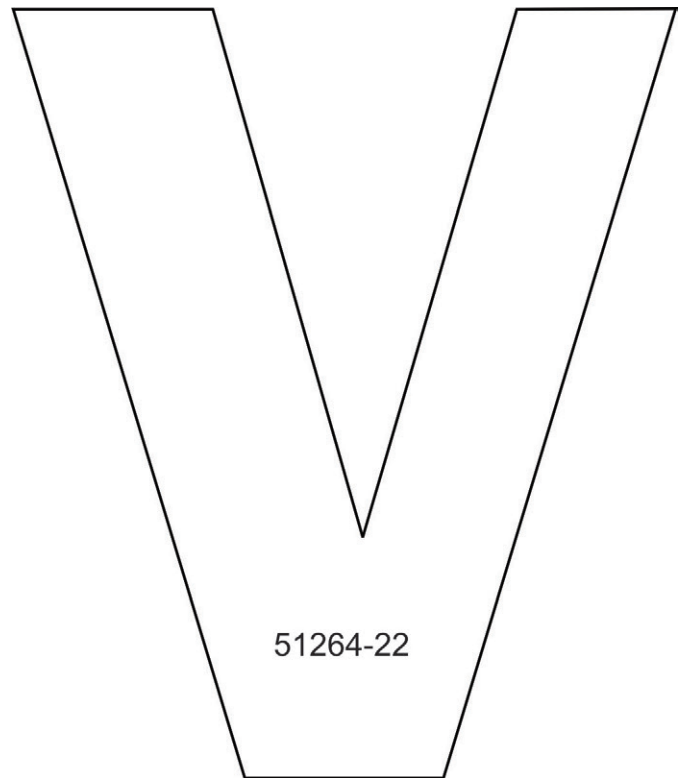

51264-22

# APPLIQUE PATTERNS



Print at 100%. No scaling. This box measures 1" x 1". Use the box as an accuracy guide when printing templates.

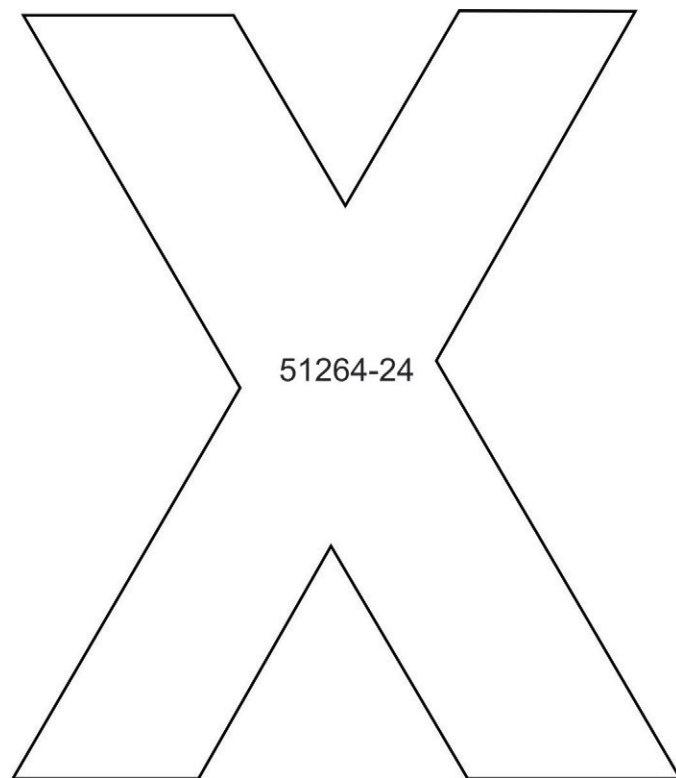



# APPLIQUE PATTERNS



Print at 100%. No scaling. This box measures 1" x 1". Use the box as an accuracy guide when printing templates.

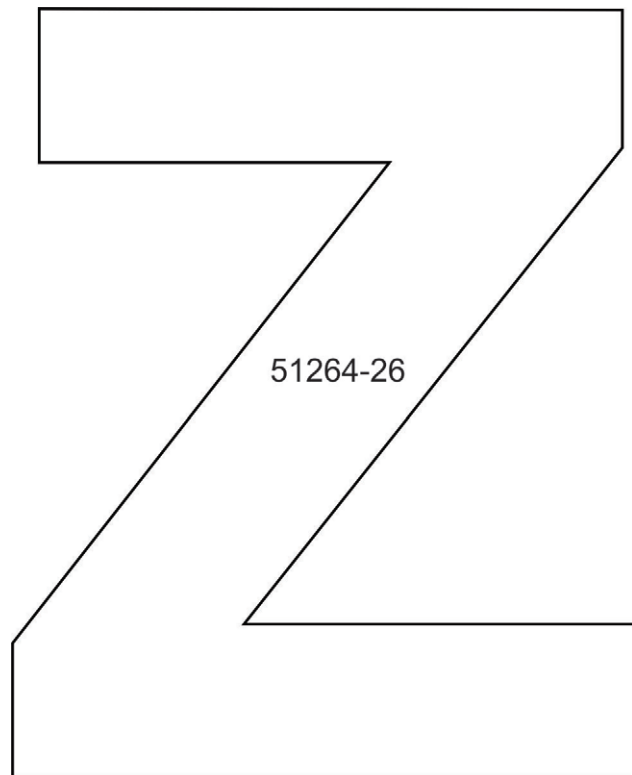
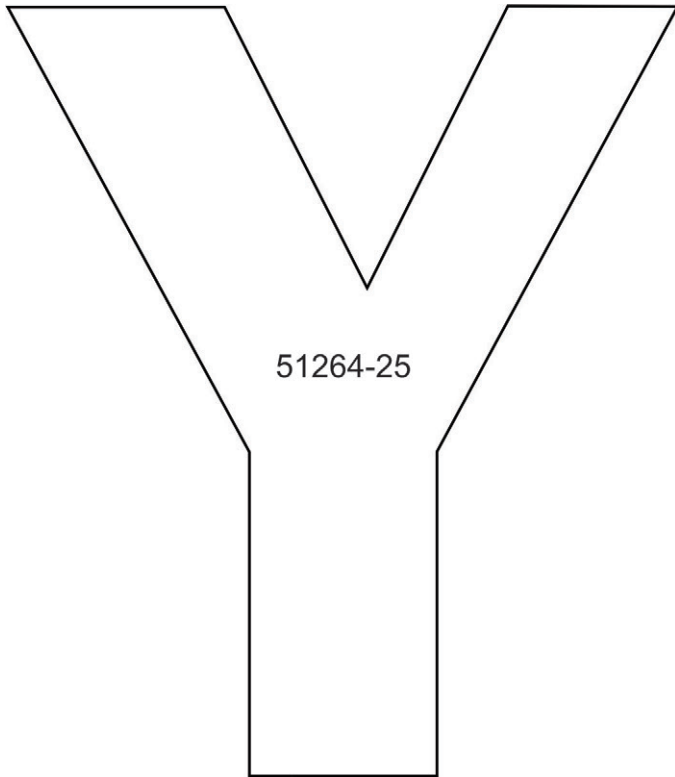

# APPLIQUE PATTERNS



Print at 100%. No scaling. This box measures 1" x 1". Use the box as an accuracy guide when printing templates.

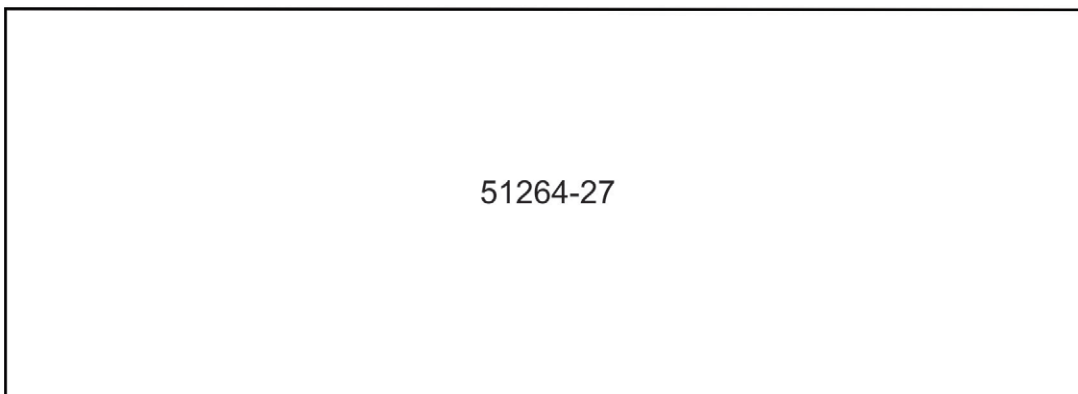
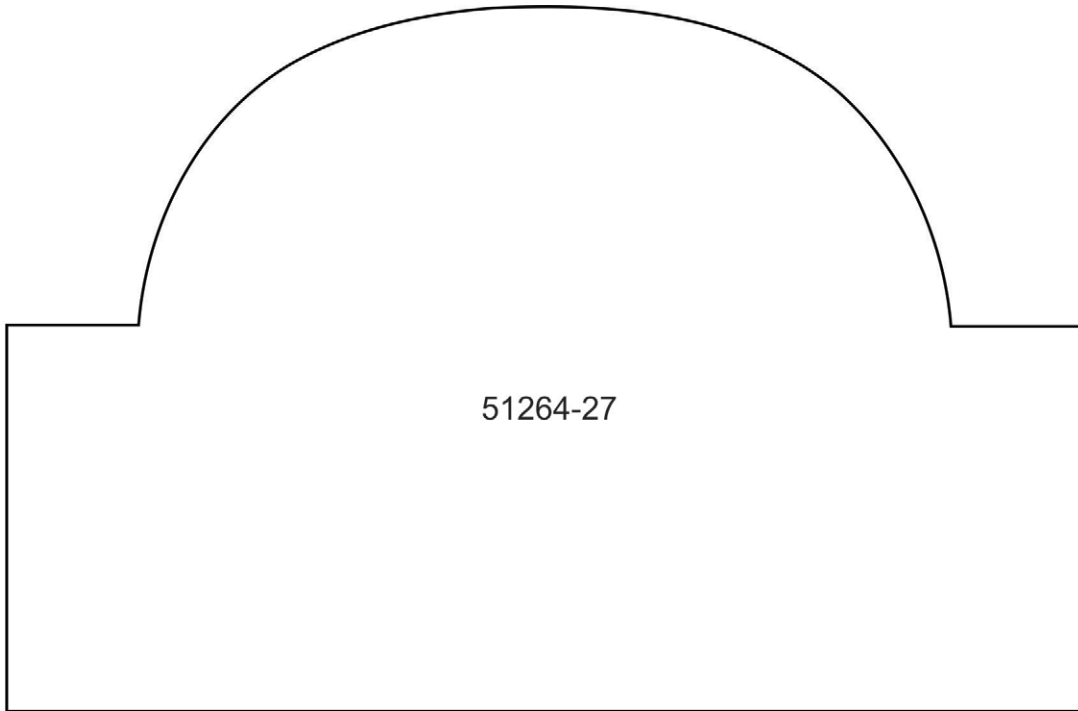

# APPLIQUE PATTERNS



Print at 100%. No scaling. This box measures 1" x 1". Use the box as an accuracy guide when printing templates.

51264-28

51264-28



# APPLIQUE PATTERNS



Print at 100%. No scaling. This box measures 1" x 1". Use the box as an accuracy guide when printing templates.

51264

# MIRRORED PATTERNS



Print at 100%. No scaling. This box measures 1" x 1". Use the box as an accuracy guide when printing templates.

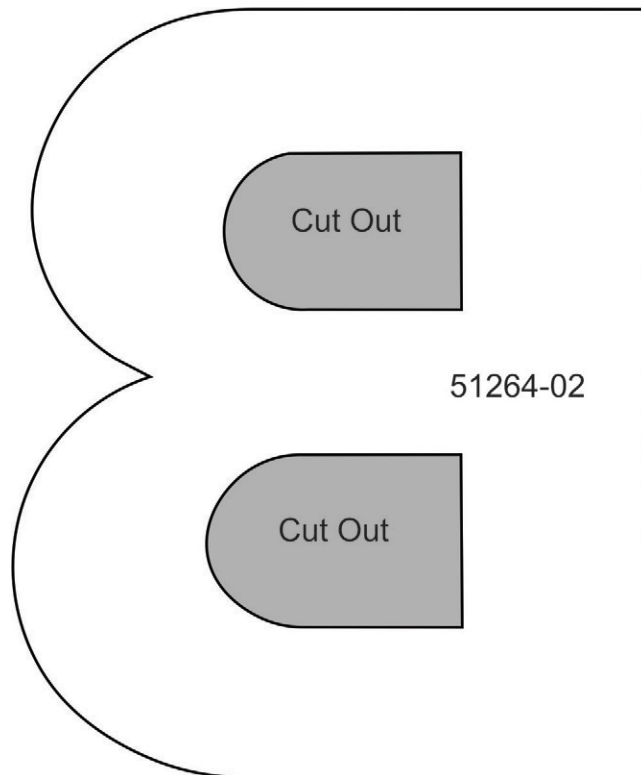
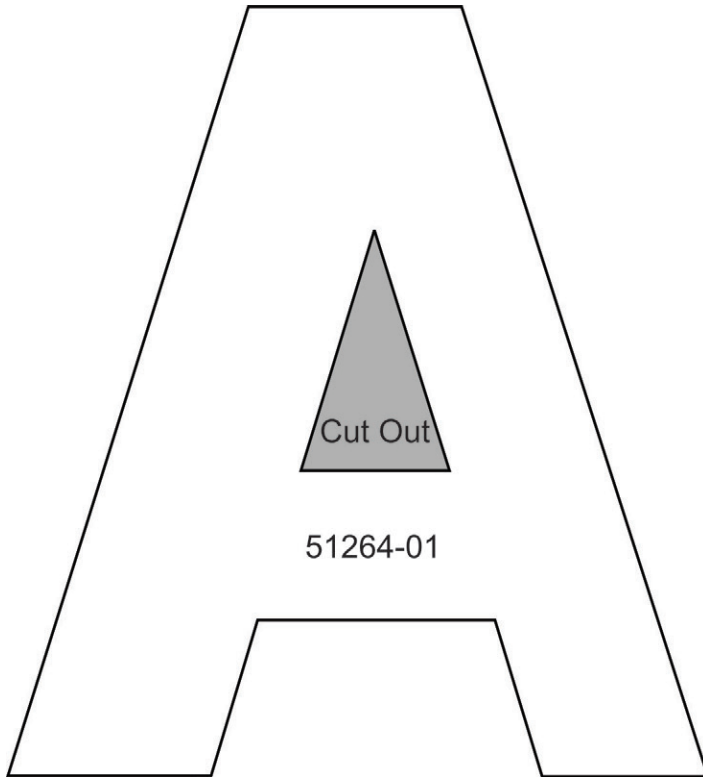

# MIRRORED PATTERNS



Print at 100%. No scaling. This box measures 1" x 1". Use the box as an accuracy guide when printing templates.

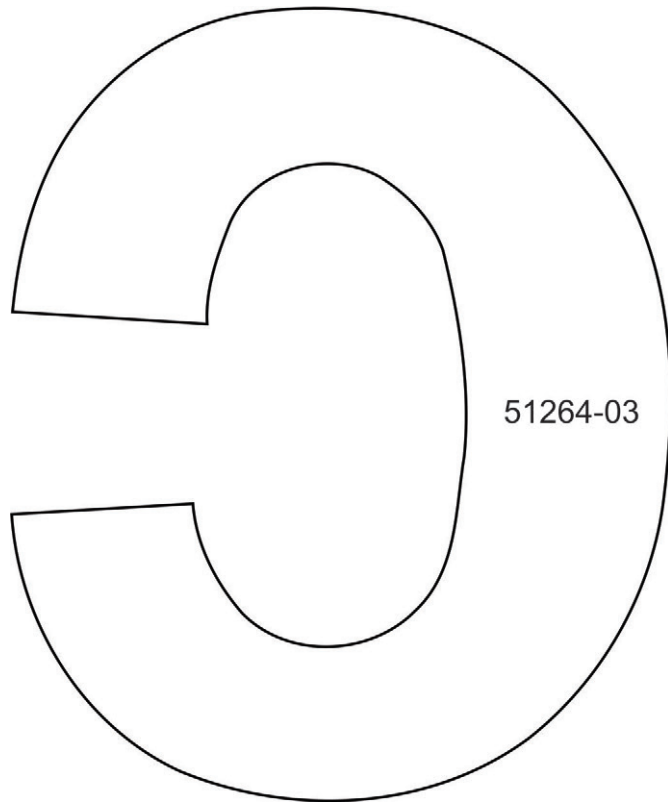

51264-03

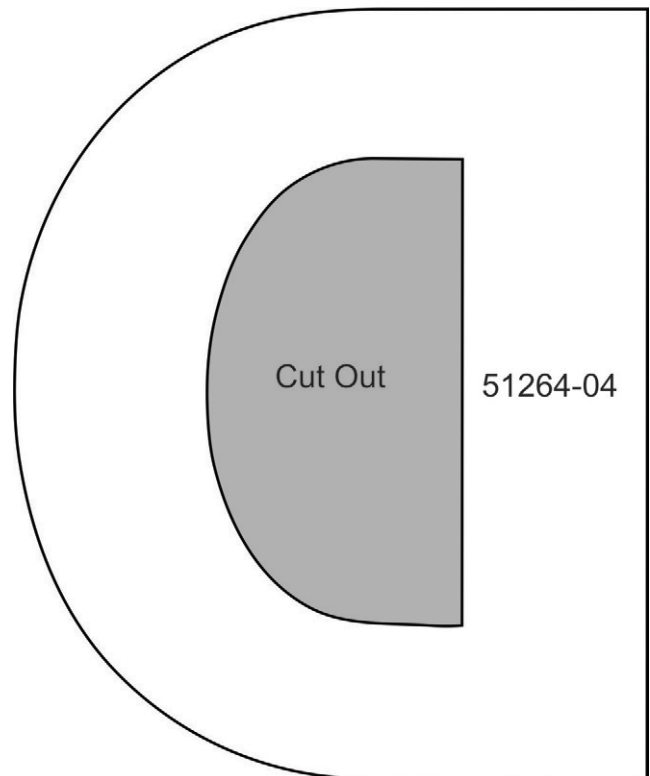

Cut Out

51264-04

# MIRRORED PATTERNS



Print at 100%. No scaling. This box measures 1" x 1". Use the box as an accuracy guide when printing templates.

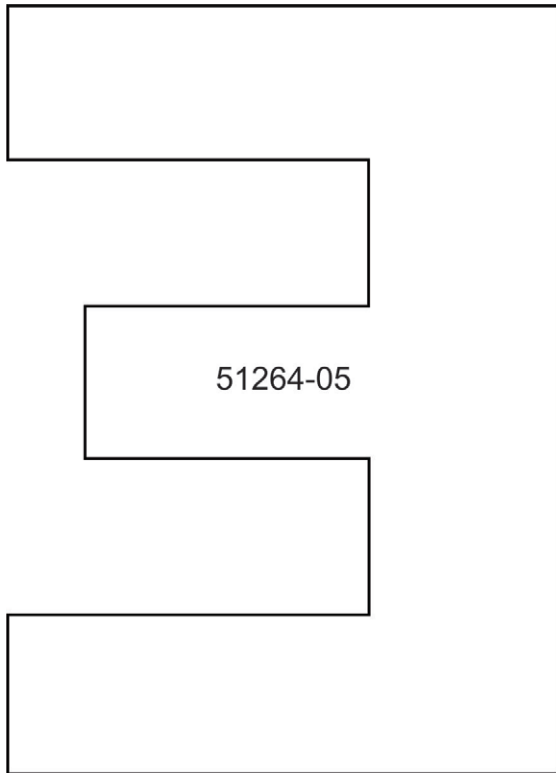

51264-05

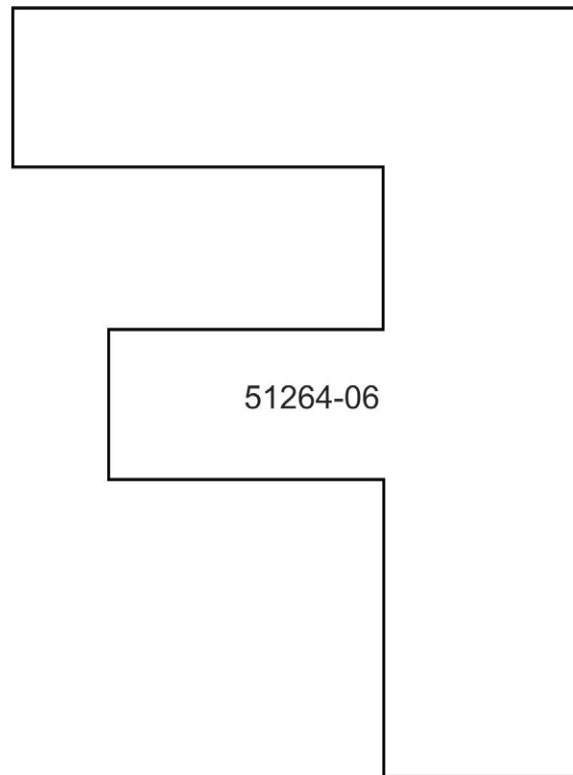

51264-06



# MIRRORED PATTERNS

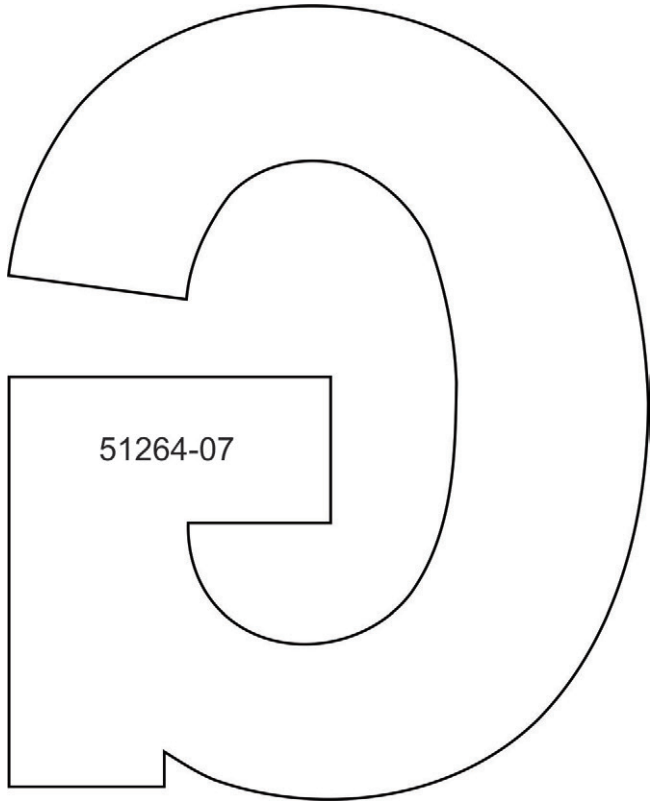

Print at 100%. No scaling. This box measures 1" x 1". Use the box as an accuracy guide when printing templates.

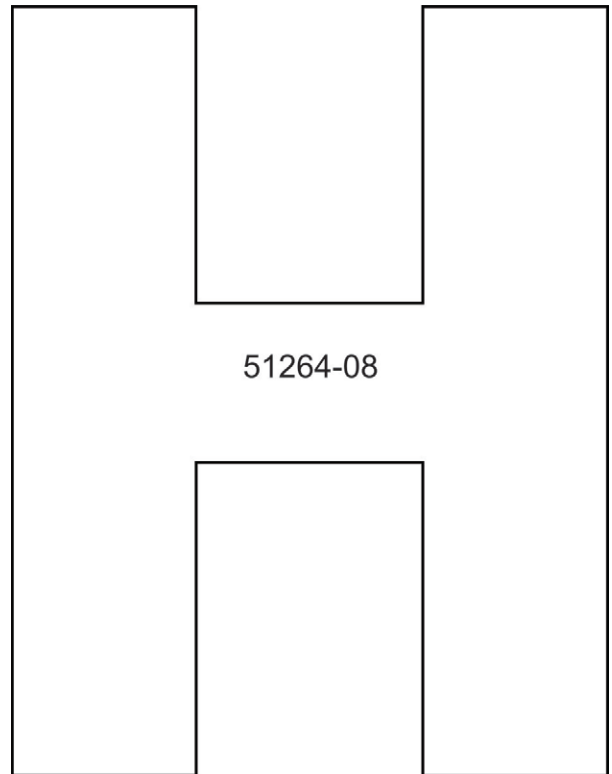

# MIRRORED PATTERNS

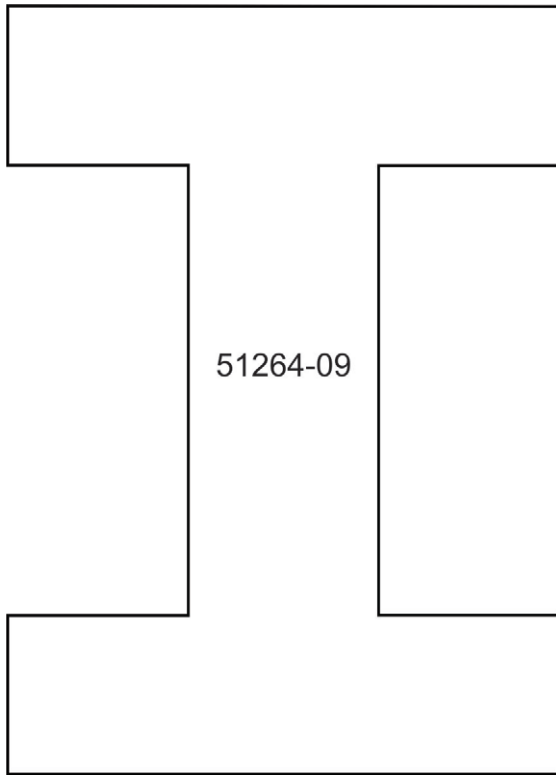

Print at 100%. No scaling. This box measures 1" x 1". Use the box as an accuracy guide when printing templates.

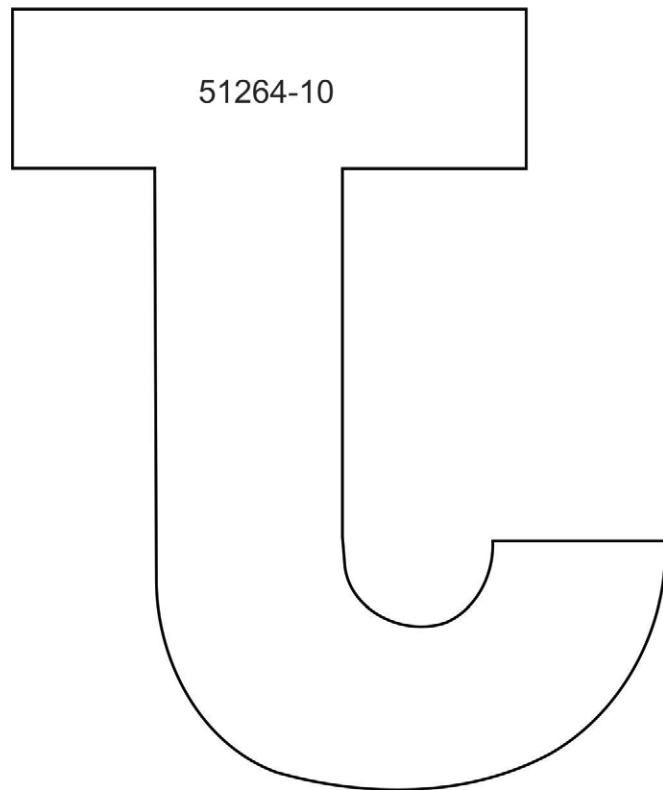

# MIRRORED PATTERNS

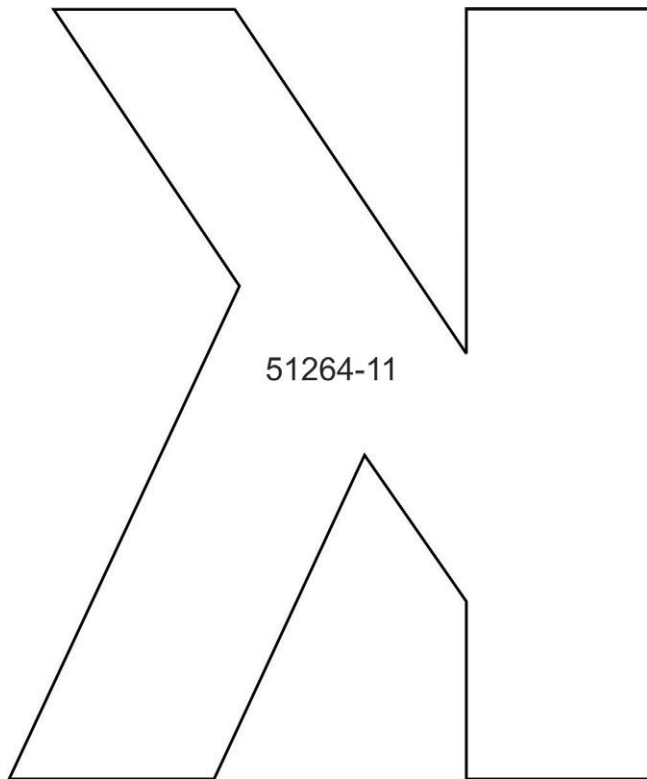

Print at 100%. No scaling. This box measures 1" x 1". Use the box as an accuracy guide when printing templates.

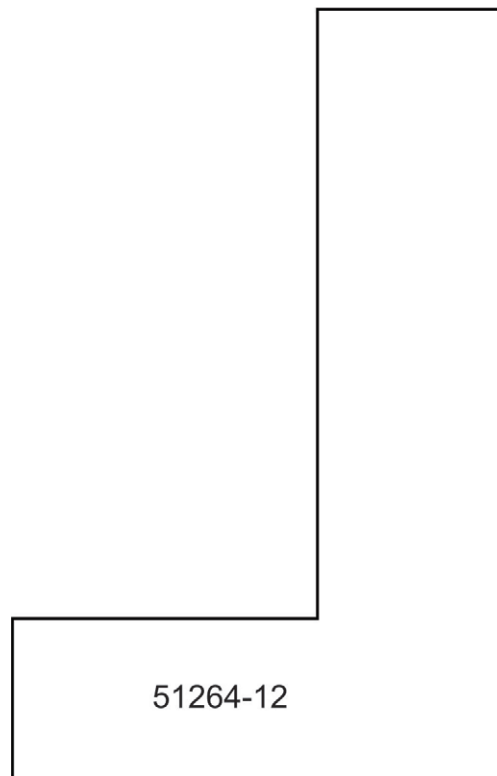

# MIRRORED PATTERNS

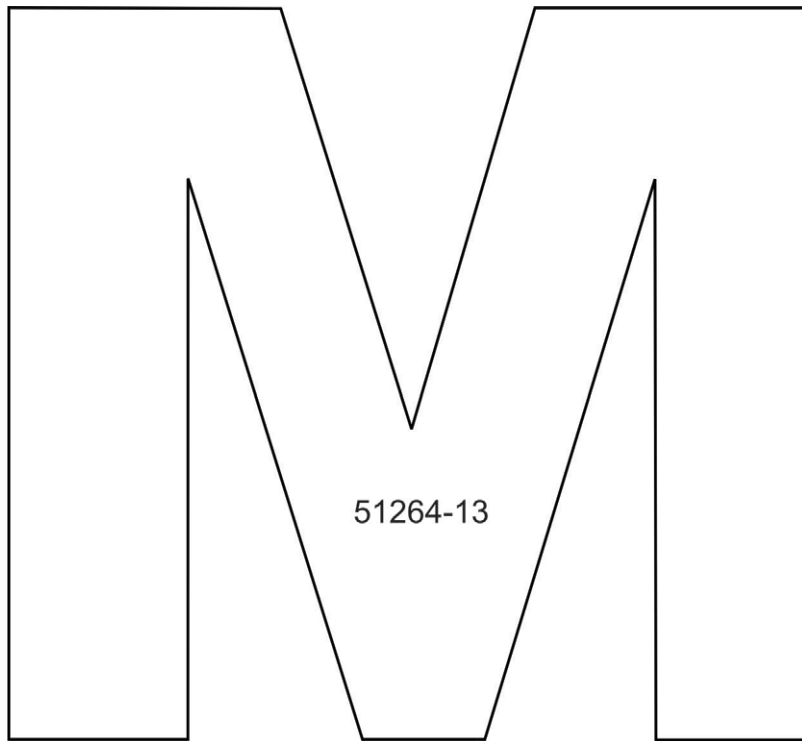

Print at 100%. No scaling. This box measures 1" x 1". Use the box as an accuracy guide when printing templates.

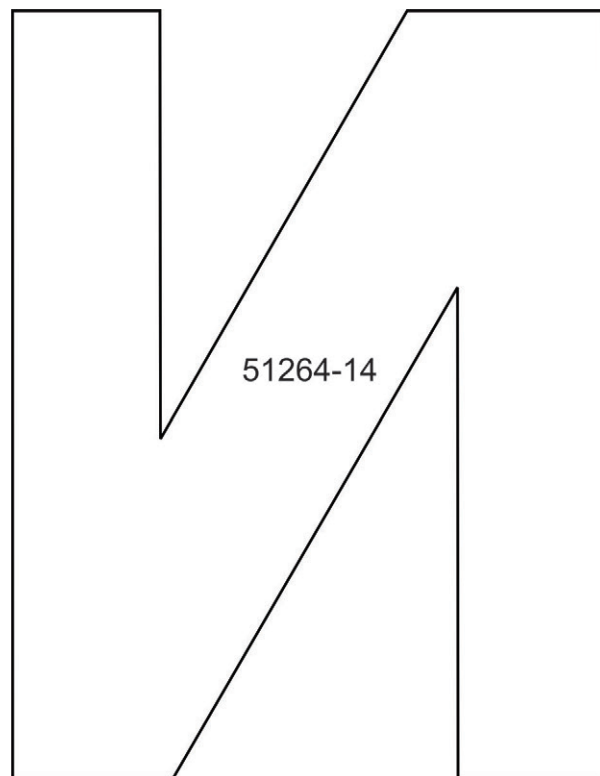



# MIRRORED PATTERNS



Print at 100%. No scaling. This box measures 1" x 1". Use the box as an accuracy guide when printing templates.

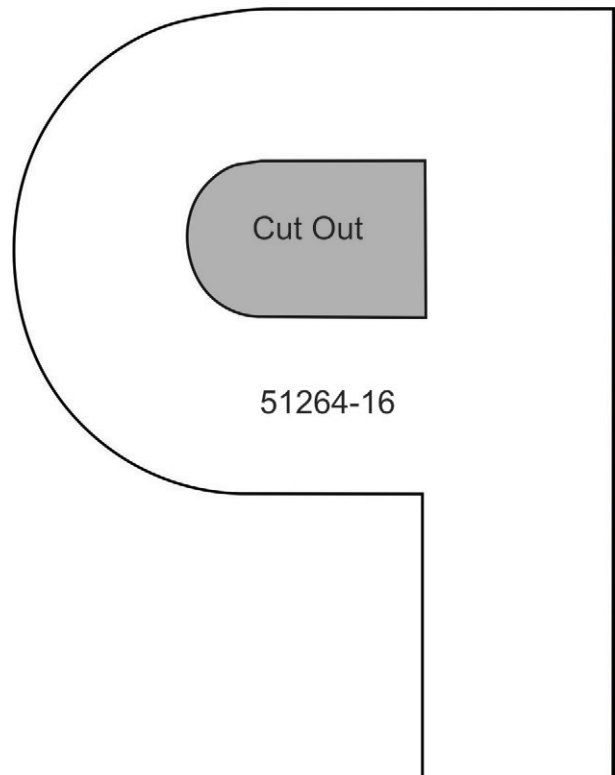
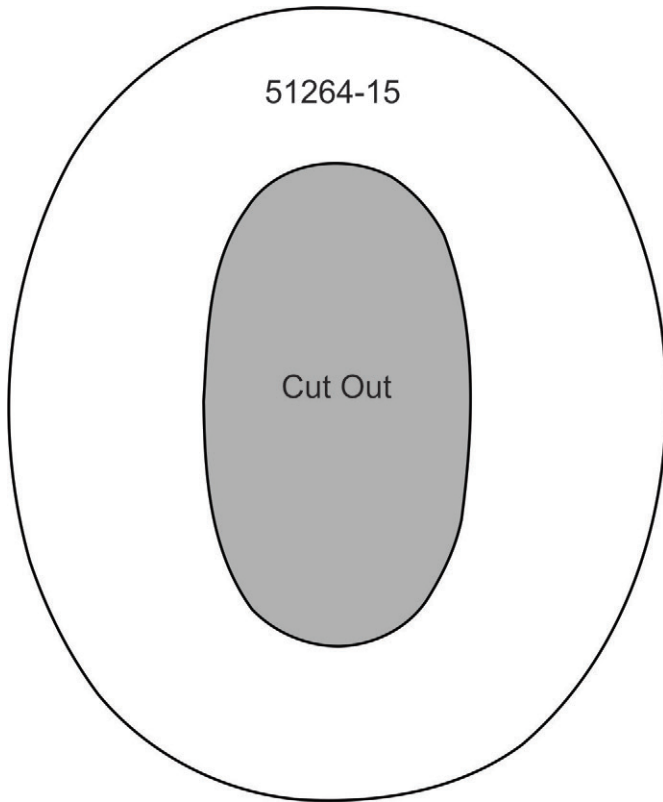

# MIRRORED PATTERNS



Print at 100%. No scaling. This box measures 1" x 1". Use the box as an accuracy guide when printing templates.

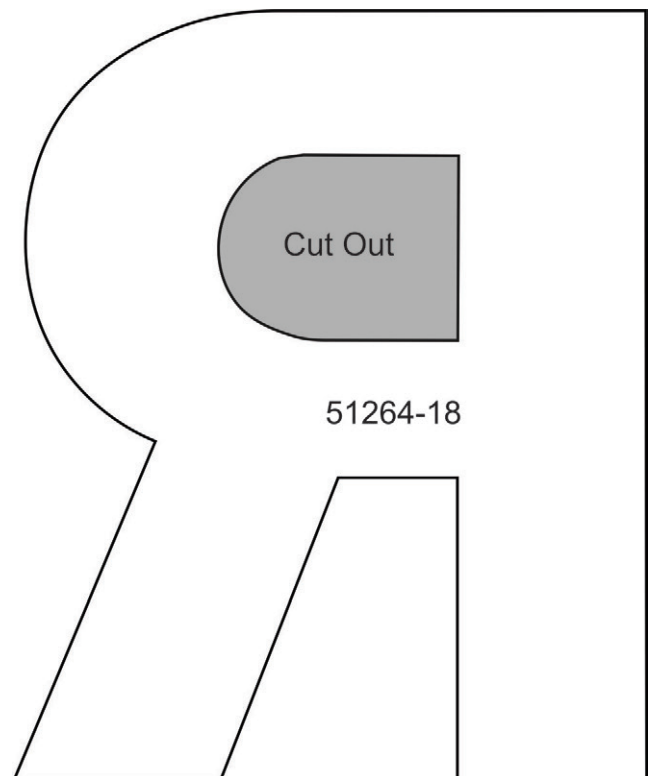
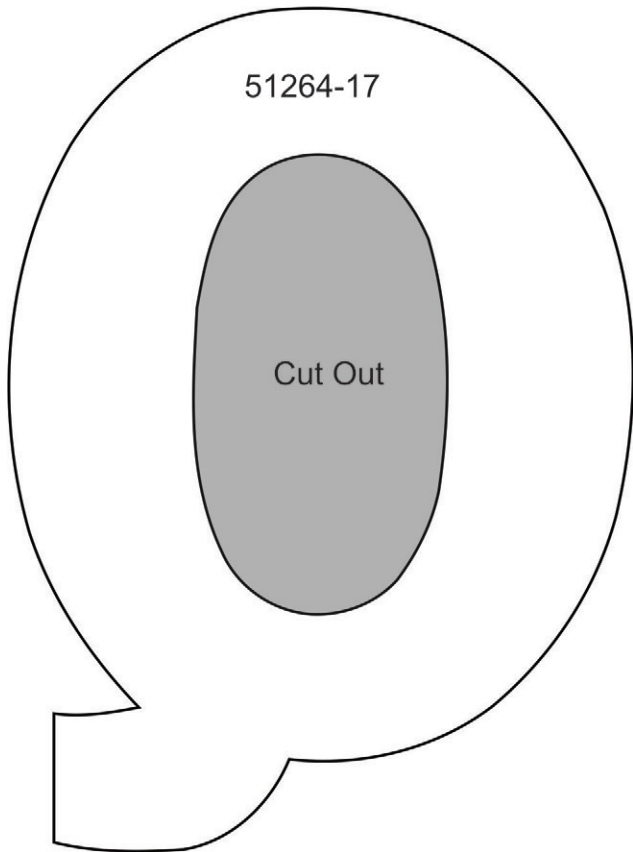

# MIRRORED PATTERNS



Print at 100%. No scaling. This box measures 1" x 1". Use the box as an accuracy guide when printing templates.

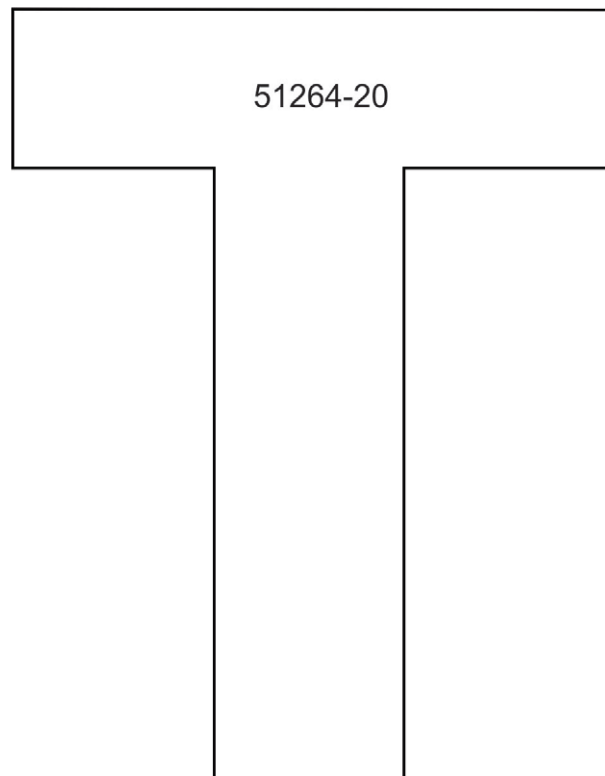
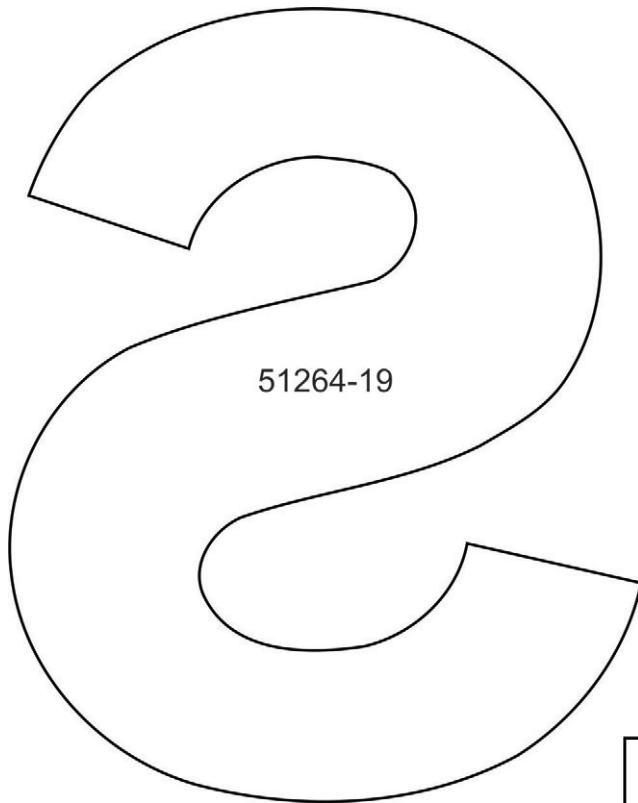

# MIRRORED PATTERNS

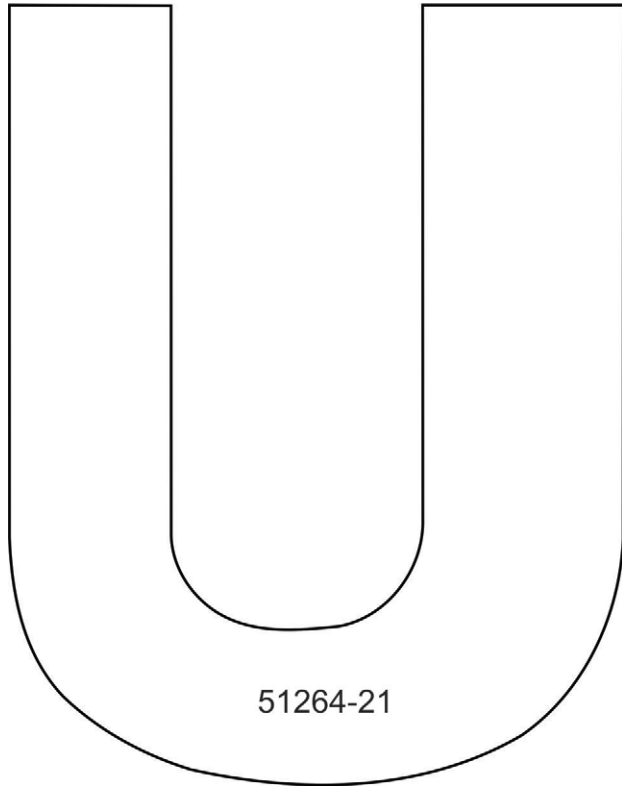

51264-21

Print at 100%. No scaling. This box measures 1" x 1". Use the box as an accuracy guide when printing templates.

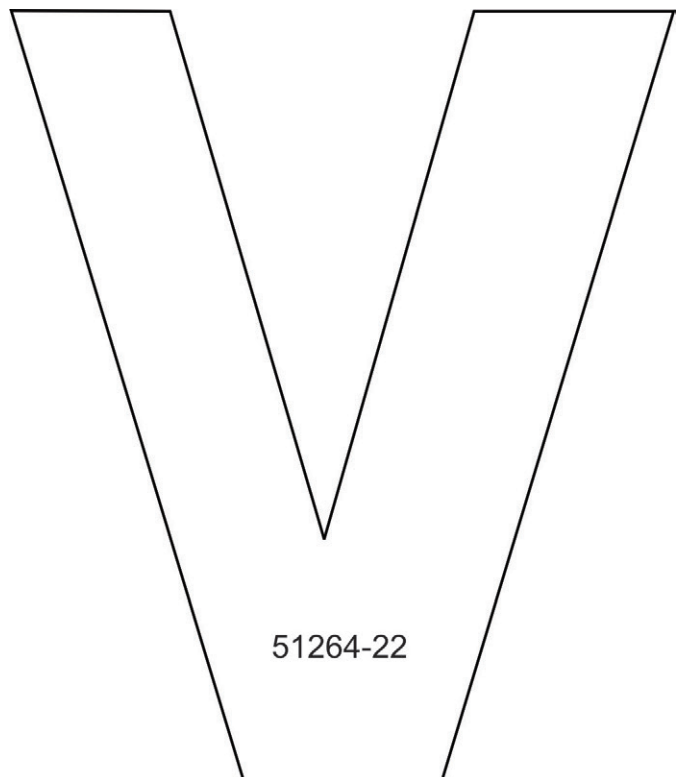

51264-22



# MIRRORED PATTERNS



Print at 100%. No scaling. This box measures 1" x 1". Use the box as an accuracy guide when printing templates.

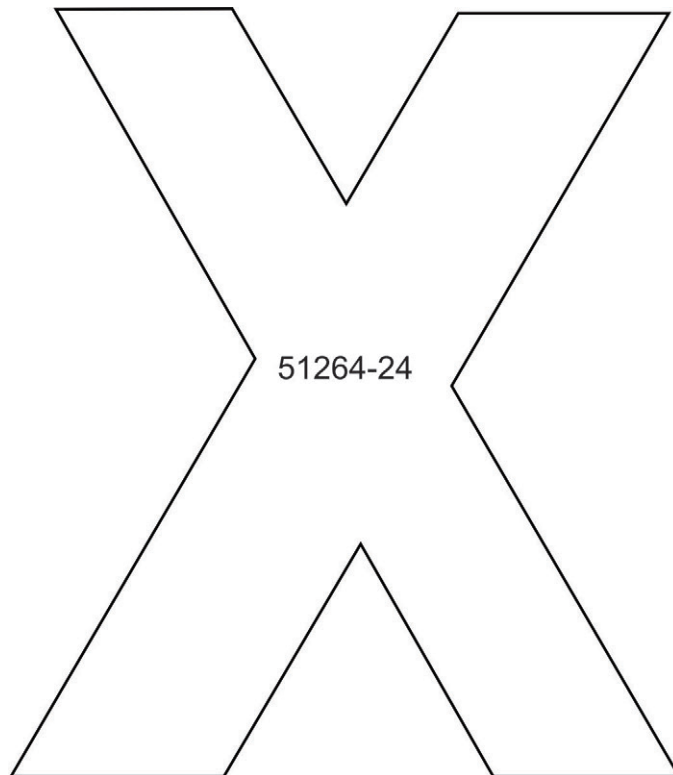

# MIRRORED PATTERNS



Print at 100%. No scaling. This box measures 1" x 1". Use the box as an accuracy guide when printing templates.

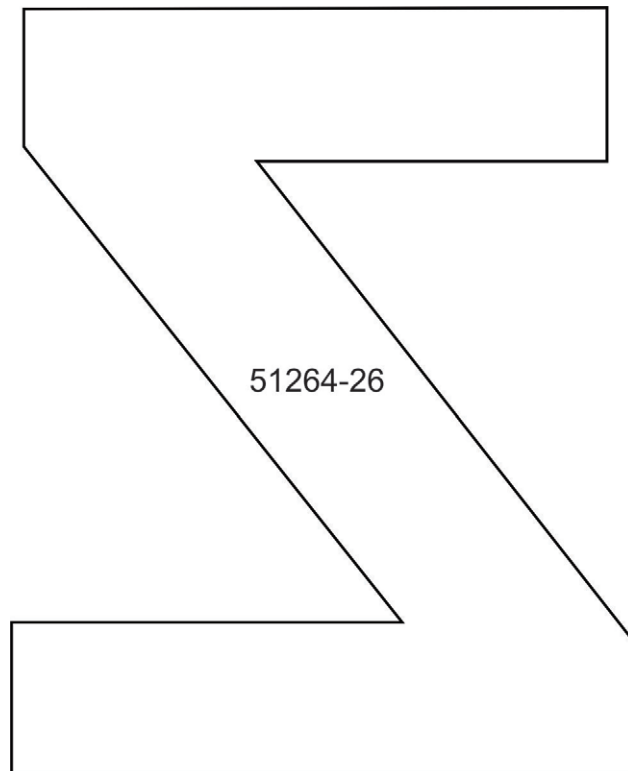
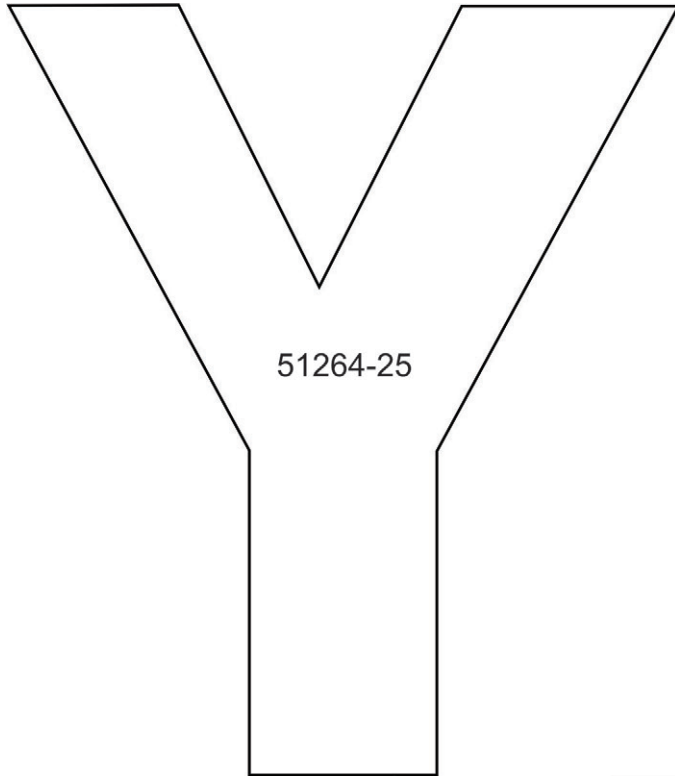

# MIRRORED PATTERNS



Print at 100%. No scaling. This box measures 1" x 1". Use the box as an accuracy guide when printing templates.

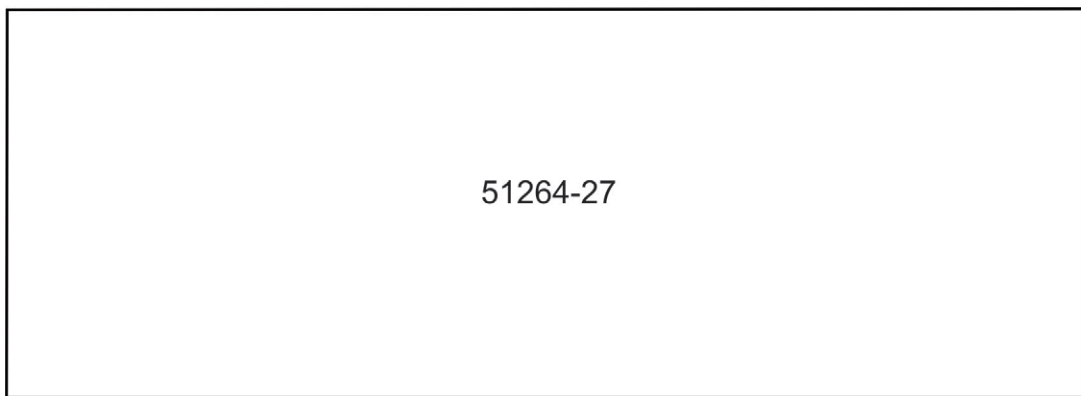
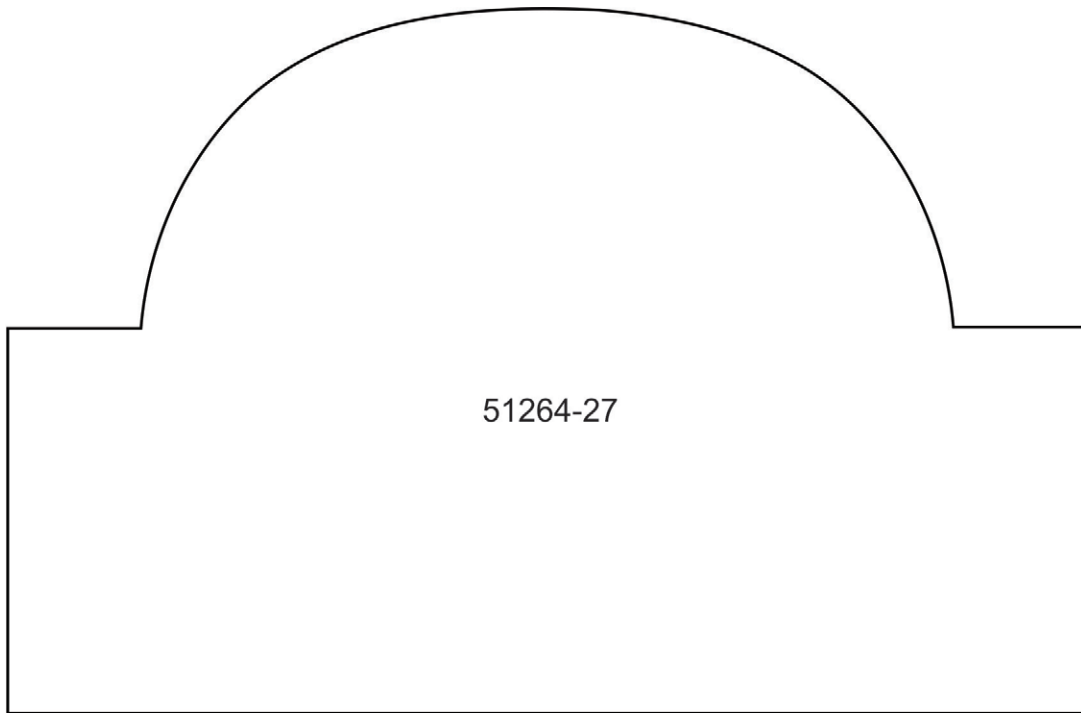

# MIRRORED PATTERNS



Print at 100%. No scaling. This box measures 1" x 1". Use the box as an accuracy guide when printing templates.

51264-28

51264-28



# MIRRORED PATTERNS



Print at 100%. No scaling. This box measures 1" x 1". Use the box as an accuracy guide when printing templates.

51264