



HG123_48 Reindeer Base Connector
2.10 X 1.22 in.
53.34 X 30.99 mm
3,800 St. **S**



HG124_48 Reindeer Middle Connector
2.08 X 2.69 in.
52.83 X 68.33 mm
8,039 St.



HG125_48 Reindeer 1 Side A
3.88 X 4.35 in.
98.55 X 110.49 mm
18,822 St.



HG126_48 Reindeer 1 Side B
3.88 X 4.35 in.
98.55 X 110.49 mm
18,801 St.



HG127_48 Reindeer 2 Side A
3.81 X 4.31 in.
96.77 X 109.47 mm
17,392 St.



HG128_48 Reindeer 2 Side B
3.81 X 4.31 in.
96.77 X 109.47 mm
17,409 St.

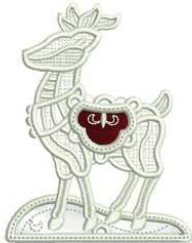

HG129_48 Reindeer 3 Side A
3.36 X 4.30 in.
85.34 X 109.22 mm
15,901 St.



HG130_48 Reindeer 3 Side B
3.36 X 4.30 in.
85.34 X 109.22 mm
15,579 St.



HG131_48 Sleigh Floor
3.89 X 6.66 in.
98.81 X 169.16 mm
24,286 St. **L**



HG132_48 Sleigh Side A
4.60 X 4.03 in.
116.84 X 102.36 mm
21,884 St.



HG133_48 Sleigh Side B
4.60 X 4.03 in.
116.84 X 102.36 mm
21,887 St.



HG134_48 Blank Square
4.42 X 4.41 in.
112.27 X 112.01 mm
33,935 St.



HG135_48 A Square
4.42 X 4.41 in.
112.27 X 112.01 mm
35,507 St.



HG136_48 C Square
4.42 X 4.41 in.
112.27 X 112.01 mm
35,164 St.



HG137_48 E Square
4.42 X 4.41 in.
112.27 X 112.01 mm
35,744 St.



HG138_48 J Square
4.42 X 4.41 in.
112.27 X 112.01 mm
35,356 St.



HG139_48 L Square
4.42 X 4.41 in.
112.27 X 112.01 mm
35,382 St.



HG140_48 N Square
4.42 X 4.41 in.
112.27 X 112.01 mm
35,878 St.



HG141_48 O Square
4.42 X 4.41 in.
112.27 X 112.01 mm
35,541 St.



HG142_48 P Square
4.42 X 4.41 in.
112.27 X 112.01 mm
35,557 St.

Z Design contains a loose fill.
R Some white areas shown are not stitched.

L Design is larger than 5" (127 mm) in either direction.
S Design is smaller than 1.5" (38.1 mm) in either direction.



HG143_48 Y Square
4.42 X 4.41 in.
112.27 X 112.01 mm
35,332 St.



HG144_48 Wreath Center
6.18 X 3.91 in.
156.97 X 99.31 mm
25,720 St. L



HG145_48 Wreath
6.94 X 3.20 in.
176.28 X 81.28 mm
27,103 St. L

Z Design contains a loose fill.
R Some white areas shown are not stitched.

L Design is larger than 5" (127 mm) in either direction.
S Design is smaller than 1.5" (38.1 mm) in either direction.

Listings below indicate color sample, stitching order and suggested thread color number, Yenmet or YLI Variegated threads.

HG123_48 Reindeer Base Connector
 1. Cover Stitches..... 0015
 2. Cover Stitch Linework.... 7009

HG124_48 Reindeer Middle Connector
 1. Placement Stitch..... 0015
 2. Cut Line and Tackdown. 0015
 3. Inner Designs..... 0015
 4. Nodes..... 0015
 5. Cover Stitches..... 0015
 6. Cover Stitch Linework.... 7009

HG125_48 Reindeer 1 Side A
 1. Top Placement Stitch.... 0015
 2. Cut Line and Tackdown. 0015
 3. Bottom Placement Stitch..... 0015
 4. Cut Line and Tackdown. 0015
 5. Inner Designs..... 0015
 6. Cover Stitch Linework.... 7009

HG126_48 Reindeer 1 Side B
 1. Top Placement Stitch.... 0015
 2. Cut Line and Tackdown. 0015
 3. Bottom Placement Stitch..... 0015
 4. Cut Line and Tackdown. 0015
 5. Inner Designs..... 0015
 6. Cover Stitch Linework.... 7009

HG127_48 Reindeer 2 Side A
 1. Top Placement Stitch.... 0015
 2. Cut Line and Tackdown. 0015
 3. Bottom Placement Stitch..... 0015
 4. Cut Line and Tackdown. 0015
 5. Inner Designs..... 0015
 6. Cover Stitch Linework.... 7009

HG128_48 Reindeer 2 Side B
 1. Top Placement Stitch.... 0015
 2. Cut Line and Tackdown. 0015
 3. Bottom Placement Stitch..... 0015
 4. Cut Line and Tackdown. 0015
 5. Inner Designs..... 0015
 6. Cover Stitch Linework.... 7009

HG129_48 Reindeer 3 Side A
 1. Top Placement Stitch.... 0015
 2. Cut Line and Tackdown. 0015
 3. Bottom Placement Stitch..... 0015
 4. Cut Line and Tackdown. 0015
 5. Inner Designs..... 0015
 6. Cover Stitch Linework.... 7009

HG130_48 Reindeer 3 Side B
 1. Top Placement Stitch.... 0015
 2. Cut Line and Tackdown. 0015
 3. Bottom Placement Stitch..... 0015
 4. Cut Line and Tackdown. 0015
 5. Inner Designs..... 0015
 6. Cover Stitch Linework.... 7009

HG131_48 Sleigh Floor
 1. Placement Stitch..... 0015
 2. Cut Line and Tackdown. 0015
 3. Inner Designs..... 0015
 4. Nodes..... 0015
 5. Cover Stitches..... 0015
 6. Cover Stitch Linework.... 7009

HG132_48 Sleigh Side A
 1. Top Placement Stitch.... 0015
 2. Cut Line and Tackdown. 0015
 3. Bottom Placement Stitch..... 0015
 4. Cut Line and Tackdown. 0015
 5. Inner Design..... 0015
 6. Cover Stitches..... 0015
 7. Cover Stitch Linework.... 7009

HG133_48 Sleigh Side B
 1. Top Placement Stitch.... 0015
 2. Cut Line and Tackdown. 0015
 3. Bottom Placement Stitch..... 0015
 4. Cut Line and Tackdown. 0015
 5. Inner Design..... 0015
 6. Cover Stitches..... 0015
 7. Cover Stitch Linework.... 7009

HG134_48 Blank Square
 1. Placement Stitch..... 0015
 2. Cut Line and Tackdown. 0015
 3. Inner Design..... 0015
 4. Cover Stitches..... 0015
 5. Cover Stitch Linework.... 7009

HG135_48 A Square
 1. Placement Stitch..... 0015
 2. Cut Line and Tackdown. 0015
 3. Inner Design..... 0015
 4. Cover Stitches..... 0015
 5. Cover Stitch Linework.... 7009

HG136_48 C Square
 1. Placement Stitch..... 0015
 2. Cut Line and Tackdown. 0015
 3. Inner Design..... 0015
 4. Cover Stitches..... 0015
 5. Cover Stitch Linework.... 7009

HG137_48 E Square
 1. Placement Stitch..... 0015
 2. Cut Line and Tackdown. 0015
 3. Inner Design..... 0015
 4. Cover Stitches..... 0015
 5. Cover Stitch Linework.... 7009

HG138_48 J Square
 1. Placement Stitch..... 0015
 2. Cut Line and Tackdown. 0015
 3. Inner Design..... 0015
 4. Cover Stitches..... 0015
 5. Cover Stitch Linework.... 7009

HG139_48 L Square
 1. Placement Stitch..... 0015
 2. Cut Line and Tackdown. 0015
 3. Inner Design..... 0015
 4. Cover Stitches..... 0015
 5. Cover Stitch Linework.... 7009

HG140_48 N Square
 1. Placement Stitch..... 0015
 2. Cut Line and Tackdown. 0015
 3. Inner Design..... 0015
 4. Cover Stitches..... 0015
 5. Cover Stitch Linework.... 7009

HG141_48 O Square
 1. Placement Stitch..... 0015
 2. Cut Line and Tackdown. 0015
 3. Inner Design..... 0015
 4. Cover Stitches..... 0015
 5. Cover Stitch Linework.... 7009

HG142_48 P Square
 1. Placement Stitch..... 0015
 2. Cut Line and Tackdown. 0015
 3. Inner Design..... 0015
 4. Cover Stitches..... 0015
 5. Cover Stitch Linework.... 7009

HG143_48 Y Square
 1. Placement Stitch..... 0015
 2. Cut Line and Tackdown. 0015
 3. Inner Design..... 0015
 4. Cover Stitches..... 0015
 5. Cover Stitch Linework.... 7009

HG144_48 Wreath Center
 1. Placement Stitch..... 0015
 2. Cut Line and Tackdown. 0015
 3. Inner Design..... 0015
 4. Letters..... 0015
 5. Cover Stitches..... 0015
 6. Cover Stitch Linework.... 7009

HG145_48 Wreath
 1. Placement Stitch..... 0015
 2. Cut Line and Tackdown. 0015
 3. Inner Design..... 0015
 4. Letters..... 0015
 5. Cover Stitches..... 0015
 6. Cover Stitch Linework.... 7009

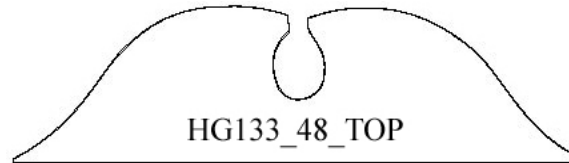
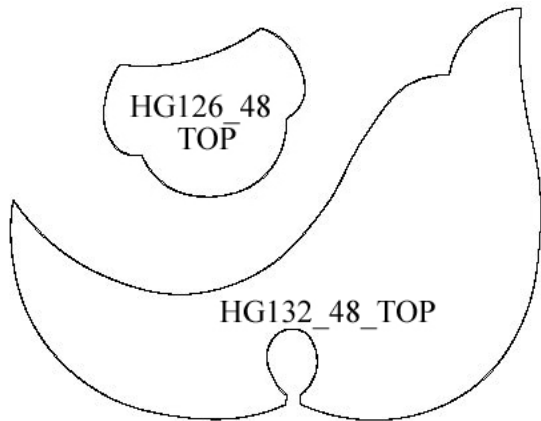
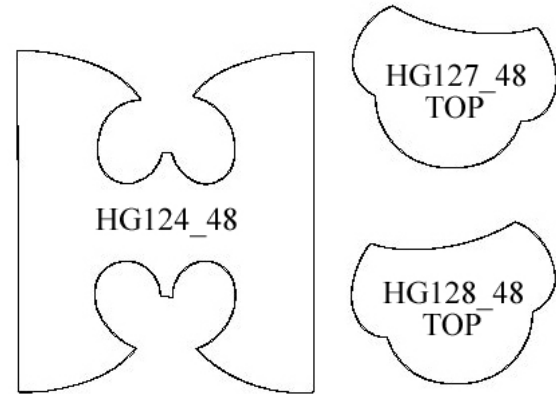
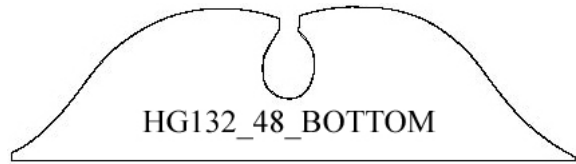
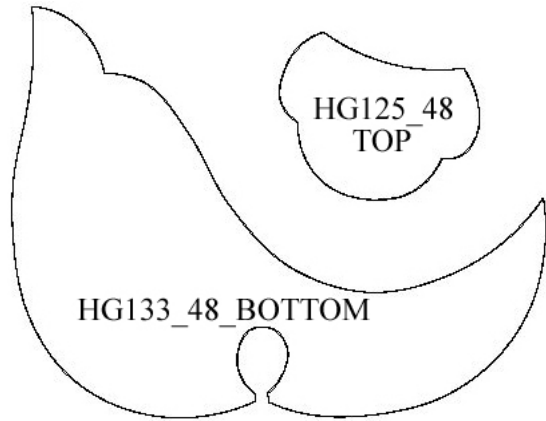
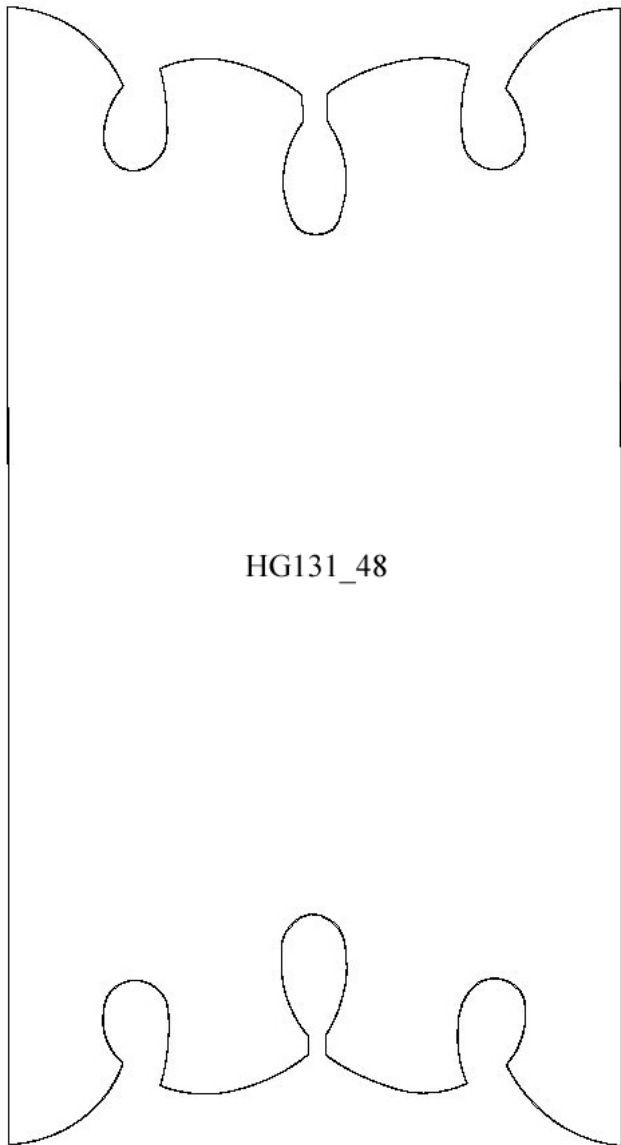

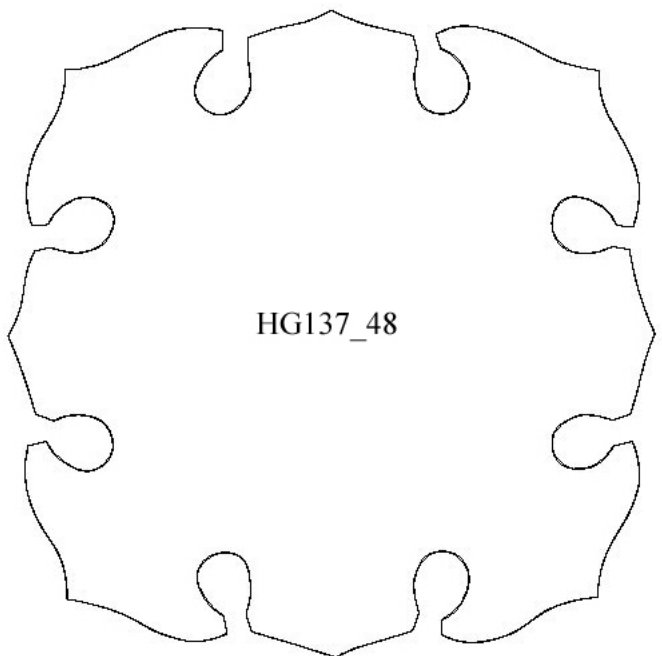
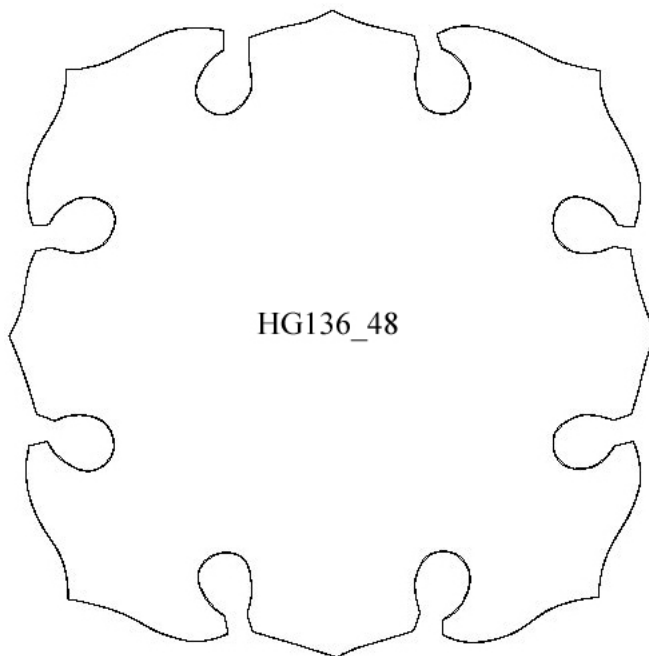
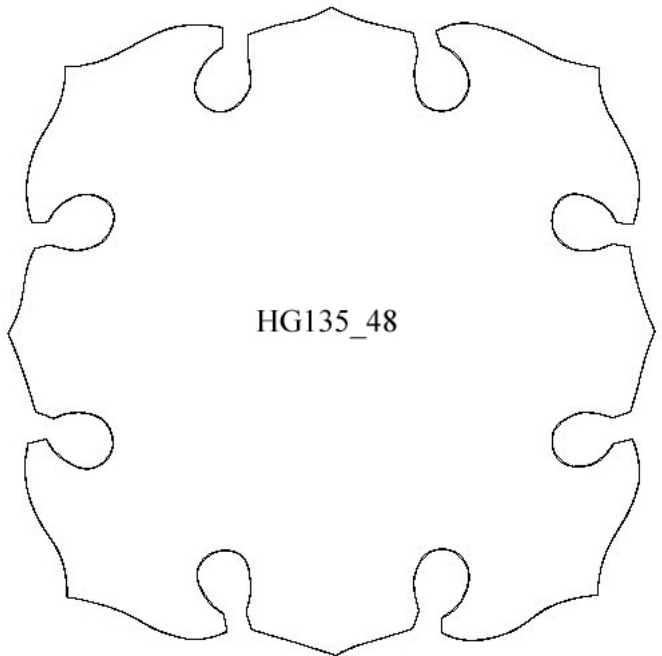
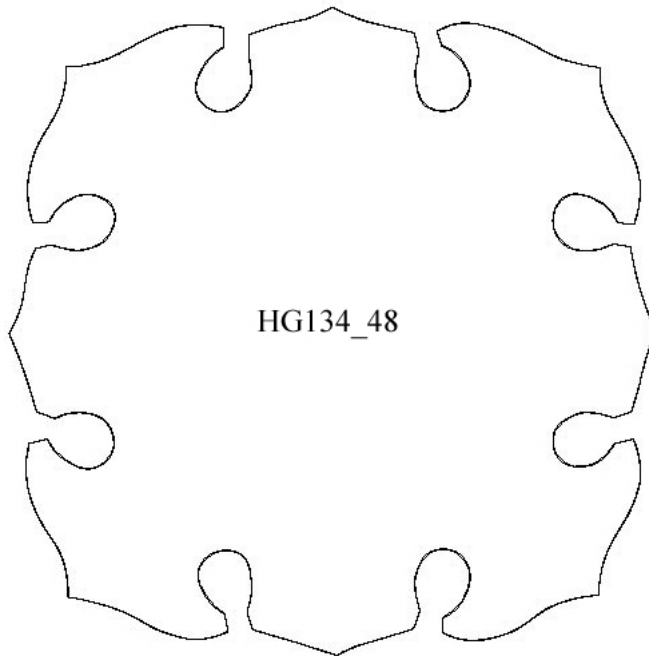
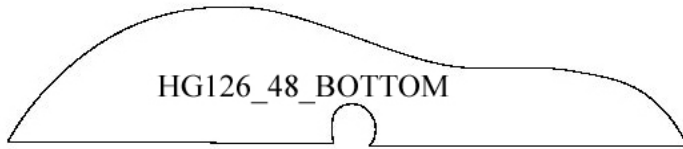
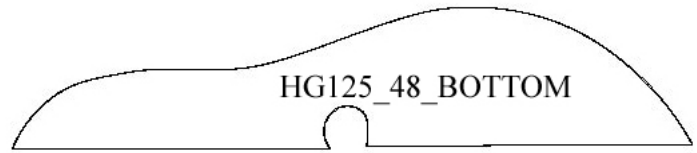

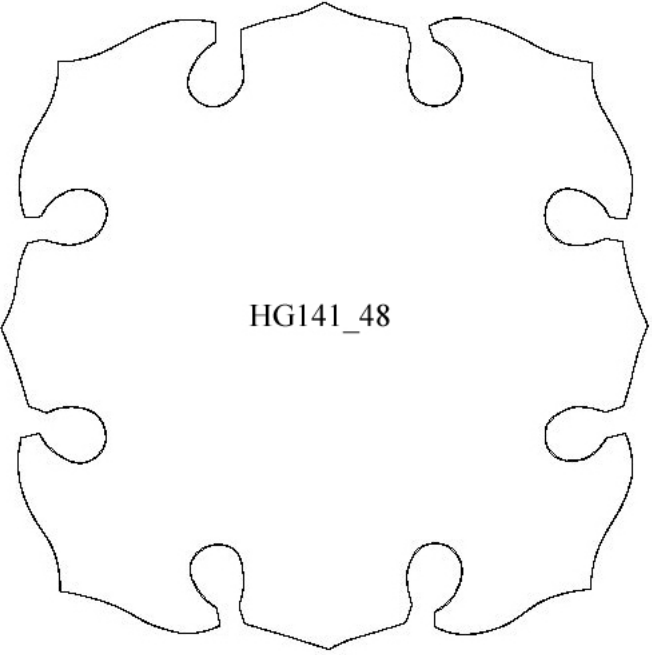
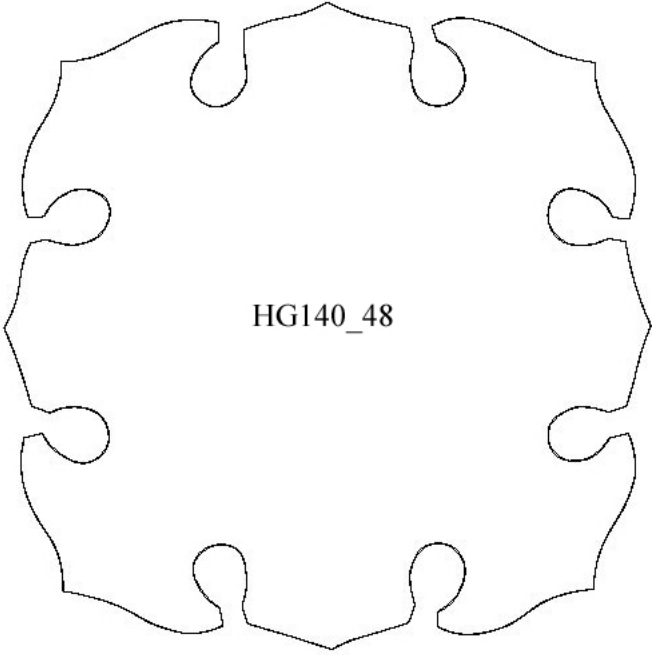
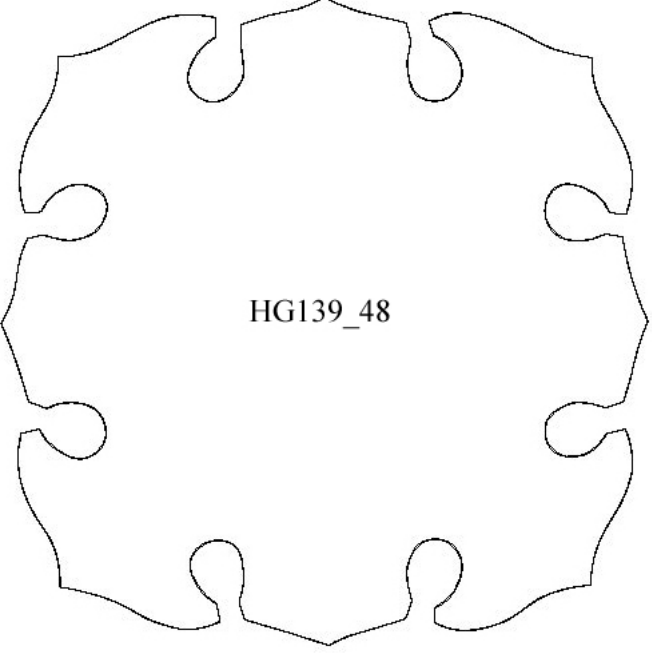
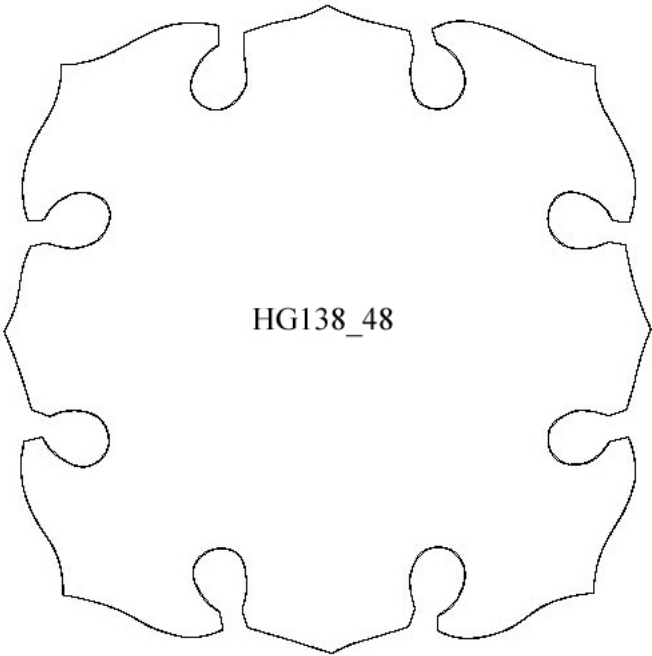
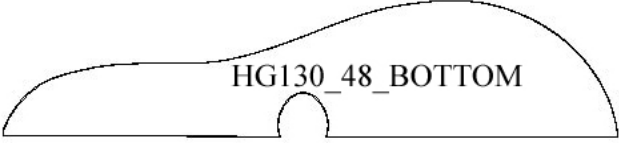
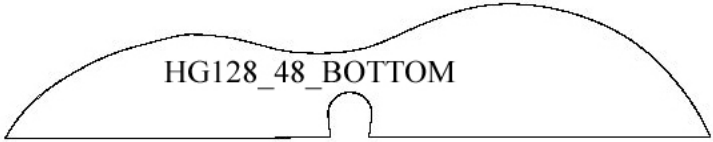

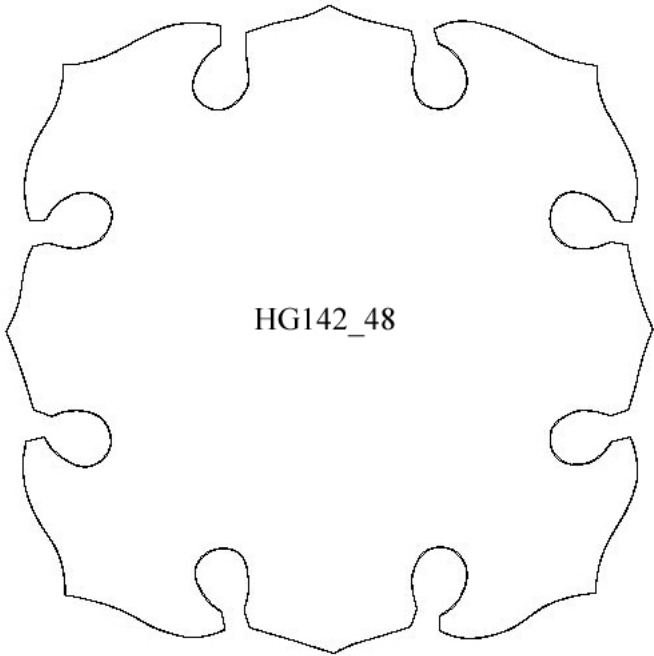

HG142_48

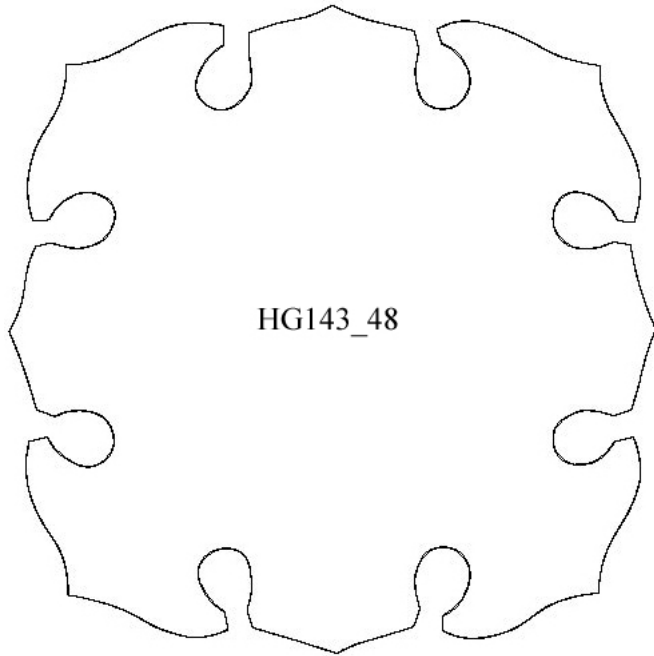

HG143_48

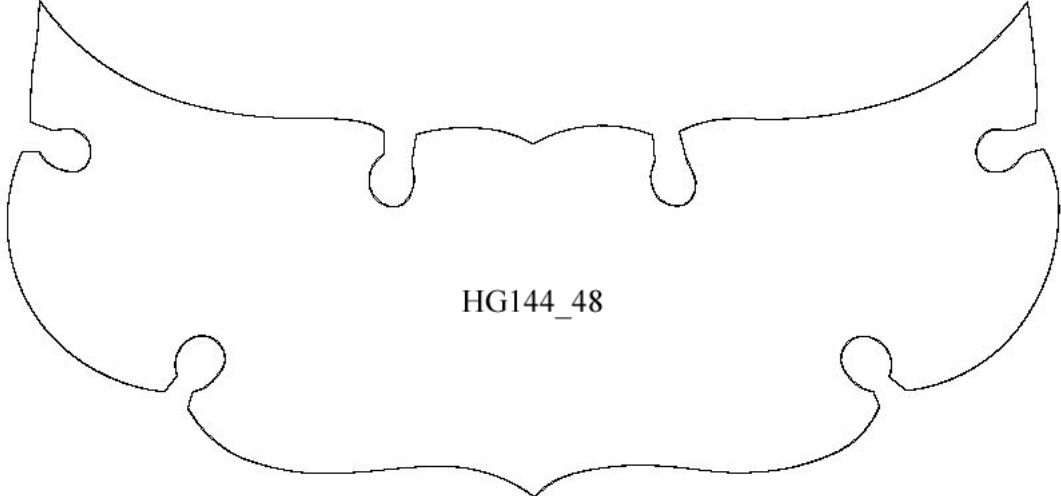

HG144_48

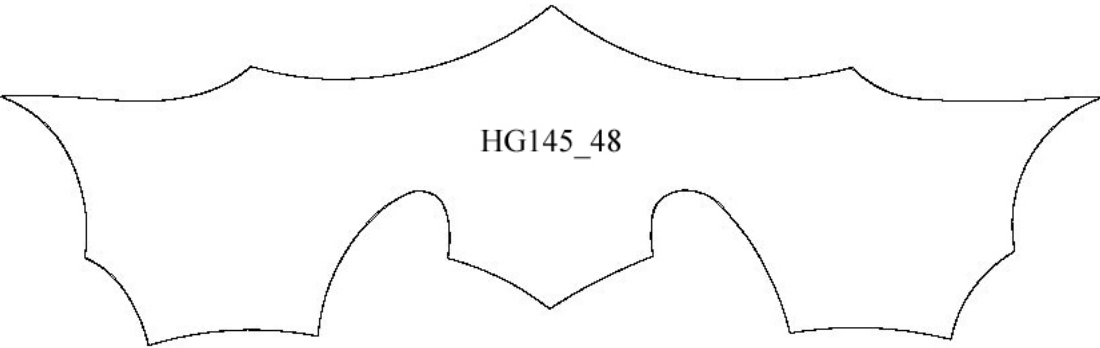

HG145_48

THE CHRISTMAS COLLECTIONS

Christmastime Freestanding Lace 3 #61049

GENERAL APPLIQUÉ AND LACE GUIDELINES

SUPPLIES:

Embroidery Thread:

- Use the same thread in the bobbin as the needle.
 - Suggested Threads:
 - Isacord Polyester Thread
 - Yenmet Metallic Thread

Needles:

- Use an Organ 80/12 needle.
 - An Organ 80/12 Titanium needle is recommended for extended needle life.

Fabric: 3" to 5" squares of cotton, cotton blend, or washable satins or sateens.

NOTE: Pre-wash all fabrics to prevent bleeding.

- Red (Benartex Jacobean Joyeux/Provence, Style 02045 / Color 87)
- Green (Benartex Apple Butter, Style 00568 / Color 35)
- Washable satins and sateens

Stabilizer:

- OESD AquaMesh or OESD BadgeMaster water-soluble stabilizer.

Notions:

- Hemostats, tweezers, and/or stiletto for inserting "buttonettes" into eyelets on three-dimensional designs

HANDY HINTS:

- For three-dimensional lace:
 - Insert the tip of the hemostats into the eyelet, grasp the buttonette, and pull through.
 - A stiletto could also be used to "push" the buttonette into the eyelet.
 - Handy Hint: Some three dimensional ornaments and designs may be easier to put together when they are slightly damp. They may be re-dampened by misting with water at any time.
- For "stiffer" lace:
 - Cut away excess stabilizer.
 - Remove remaining stabilizer by rinsing under warm running water.
 - DO NOT RINSE away all the stabilizer for a "stiffer" lace. However, do note that the thread may appear a shade darker if stabilizer is not removed completely.
 - If you happen to wash too much out, easily re-stiffen by diluting some stabilizer scraps in water and dipping the item in the solution.
- For very soft lace:
 - Cut away excess stabilizer.
 - Remove remaining stabilizer by rinsing under warm running water until all traces of the stabilizer are gone.
 - Note: If lace should become too limp to work with, dissolve scraps of AquaMesh in warm water and apply to the lace.

- 1) Hoop two layers of OESD AquaMesh or one layer of OESD BadgeMaster water-soluble stabilizer.
- 2) Attach the hoop to the machine and select the design of your choice.
- 3) Stitch the 1st Color (the Placement Stitch). **
- 4) Remove the hoop from the machine. DO NOT remove the stabilizer from the hoop.
- 5) Cut a rectangle of fabric slightly larger than the stitching in the hoop.
 - a. OPTIONAL—for reversible design, cut two rectangles. Adhere wrong sides together with 101 Quilt Basting Spray.
- 6) Center the fabric right side up in the hoop over the stitched lines. See Photo 01
- 7) Return the hoop to the machine and stitch Color 2 (the Cut Line). See Photo 02
- 8) Remove the hoop from the machine. DO NOT remove the stabilizer from the hoop.
- 9) Trim the excess fabric of the (one or two) layers of fabric from the outside of the stitched lines. See Photo 03

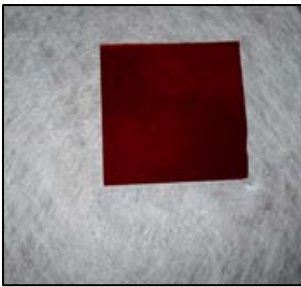

Photo 01



Photo 02



Photo 03

- 10) Return the hoop to the machine and finish stitching the design.
- 11) If more than one appliqué fabric is used in the design, stitch the second placement line for the second fabric. See Photo 04
- 12) Cut a rectangle of fabric slightly larger than the stitched lines in the hoop.
 - a. OPTIONAL—for reversible design, cut two rectangles. Adhere wrong sides together with 101 Quilt Basting Spray.
- 13) Center the fabric right side up in the hoop over the stitched lines. See Photo 05
- 14) Return the hoop to the machine and stitch the next color (the Cut Line). See Photo 06

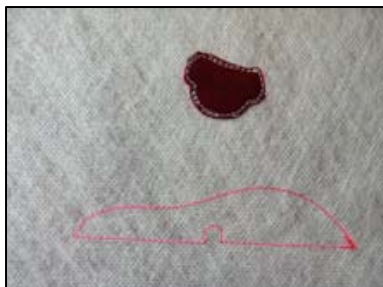

Photo 04



Photo 05



Photo 06

- 15) Trim the excess fabric from the outside of the stitched lines. See Photo 07
- 16) Continue stitching the design. See Photo 08
- 17) Remove the hoop from the machine and trim excess stabilizer from the design.
- 18) Rinse away remaining stabilizer and allow it to dry.

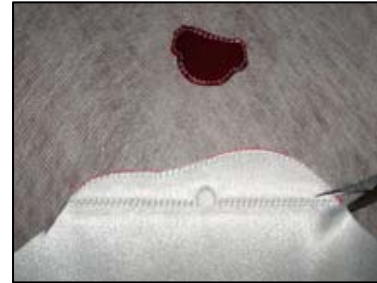

Photo 07



Photo 08

** TO USE PRE-CUT APPLIQUÉ SHAPES

- Print the desired appliqué pieces provided on the CD.
- Roughly cut around appliqué shape.
- Lightly spray the wrong side of the paper with 101 Quilt Basting Spray (temporary spray adhesive).
- Place the paper on the right side of the appliqué fabric and cut out the appliqué shape.
- With the paper still attached, lightly spray the wrong side of the fabric.
- Follow Steps 1 through 3 from above instructions
- Place the wrong side of the appliqué piece over the Placement Stitch in the hoop. Carefully remove the paper pattern from the top of the appliqué and continue stitching the design.

THE OESD CHRISTMAS COLLECTIONS

Christmastime Freestanding Lace 3 #61049 REINDEER & SLEIGH



Reindeer Instructions

- Follow the GENERAL APPLIQUÉ AND LACE INSTRUCTIONS on CD to stitch the six reindeer, three appliqué connectors, and the three white diamond shaped connector pieces.
 - Glitz individual pieces as desired.
 - Insert the five buttonettes on one side of the rectangular appliqué connector into the five eyelets on the reindeer, from the inside of the reindeer to the outside.
 - Insert the five buttonettes on the other side of the same connector piece into the five eyelets of the matching reindeer piece from the inside of the reindeer to the outside.
 - Insert the buttonette of the diamond shape connector into the eyelet at the lower center of the reindeer piece from the inside out.
- Insert the opposite buttonette on the connector into the eyelet at the base of the 2nd reindeer.
 - Repeat with the remaining two sets of reindeer.



SLEIGH

- Follow the GENERAL APPLIQUÉ AND LACE INSTRUCTIONS on CD to stitch the two side pieces and one center appliqué piece for sleigh.
- The connecting piece will button into the two side pieces of the sleigh.
- To connect all the reindeer and the sleigh, feed ribbon (approximately 1 ½ yards – width 3/8" wide) from the sleigh into the side of each reindeer. Feed across the front reindeer and back to the sleigh like reins.



THE OESD CHRISTMAS COLLECTIONS

Christmastime Freestanding Lace 3 #61049 APPLIQUE SQUARES



Instructions:

- Follow the GENERAL APPLIQUÉ AND LACE INSTRUCTIONS to stitch letters for your choice of words: Joy, Peace, or Noel.
- If desired, stitch the appliqué square without a letter to create a coaster, or use you machine's lettering feature to add the alphabet letter of your choice.
- Glitz individual pieces as desired.
- Insert ribbons and hang letters individually or in groupings.

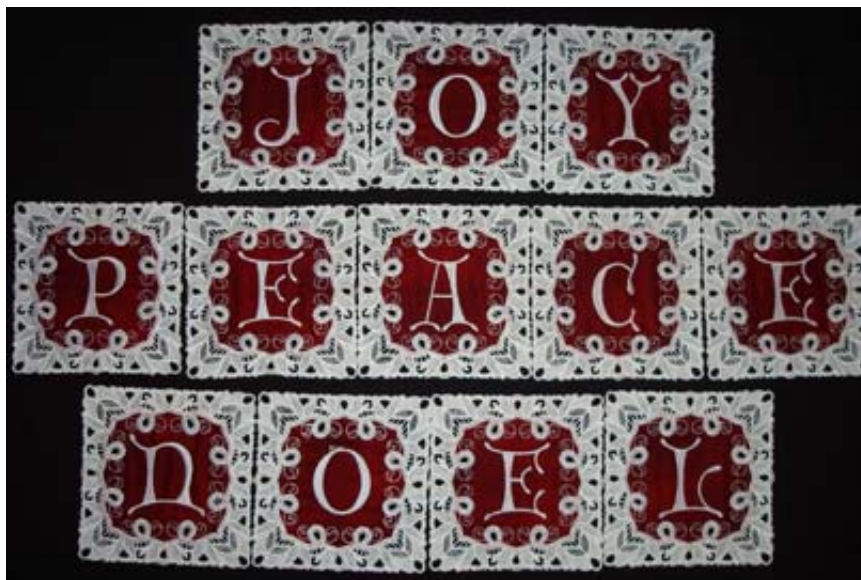

THE OESD CHRISTMAS COLLECTIONS

Christmastime Freestanding Lace 3 #61049 BELL PULL WALLHANGING

This delightful bell pull will add a creative accent to any wall. This project uses a quilt block as the basis, and will be an easy holiday decoration.



SUPPLIES:

OESD Christmas Collection CD #3
One—Fat Quarter Red Benartex fabric
One—Fat Quarter Green Benartex fabric
One—2" X 9" Benartex fabric for hanger loop
One—9½" X 28½" Benartex fabric for Back
Isacord Polyester Embroidery Thread for needle
OESD Bobbin Thread
Metrosene All Purpose Polyester Sewing Thread
Organ Embroidery Needles
101 Quilt Basting Temporary Spray Adhesive
OESD AquaMesh Stabilizer
2¼ yards of Piping
20" trim for hanging
¼" X 9" dowel rod
Embroidery machine
Sewing machine

MAKE THE PIECED SQUARES

Note: Stitch all seams using a ¼-inch seam allowance.

Cutting instructions for one block:

- From the red fabric, cut eight 2¾" X 2¾" squares and one 5" X 5" square.
- From the green fabric, cut four 5" X 2¾" rectangles and four 2¾" squares.

To construct one block:

- Place one red 2¾" square right sides together with one of the green 5" X 2¾" rectangles.

THE OESD CHRISTMAS COLLECTIONS

- Stitch across the diagonal center of the red square. Trim the excess leaving a ¼" seam allowance. Photo 01 Press the seam to the red side.
- Repeat with the second 2¾" square on the opposite side. Photo 02 Press the seam toward the red side.
- This creates a Flying Geese unit. Photo 03
- Repeat the above instructions to complete three more Flying Geese units.



Photo 01



Photo 02



Photo 03

- For the strip segment, stitch a green 2¾" square on each end of two Flying Geese units. Press seam to the green side. Photo 04
- For the center segment, stitch one Flying Geese unit on each side of the center 5" red square. Press seam to the red side. Photo 05



Photo 04



Photo 05

- To complete the block, stitch one strip segment to the top and one to the bottom of the center segment. Press seams to center. Photo 06
- Finished block is 9½" X 9½". Photo 06
- Repeat above instructions to complete three blocks.
- Stitch the three blocks together. Press seams to one side. Photo 07



Photo 06



Photo 07

EMBROIDER THE LETTERING SQUARES

- Follow the GENERAL APPLIQUÉ AND LACE INSTRUCTIONS on CD to the appliqué letters J, O, and Y.
- Stitch the completed lettering squares to the blocks. Photo 08

CONSTRUCT THE BELL PULL

- Sew the piping on all four sides of the front.
- Finish the ends of the hanger loop by folding under the two short ends and topstitching. Fold wrong sides together and press. Stitch to the top of the backing fabric.
- Place the backing right sides together on the front and stitch on all four sides leaving an opening to turn.
- Turn to the right side.
- Stitch the opening closed.
- Place a dowel rod in the hanger loop.
- Add trim or cording to hang.

OPTION:

- Create your own bell pull using the quilt block of your choice.
- The block needs to be a block with a center square that will accommodate the Letter.
- Use colors for the block to match the color scheme of your choice.



Photo 08

THE OESD CHRISTMAS COLLECTIONS

Christmastime Freestanding Lace 3 #61049 WREATH



Wreath Instructions:

- Follow the GENERAL APPLIQUÉ AND LACE INSTRUCTIONS on CD to stitch the five wreath appliqué wreath pieces and one center banner piece.
- Glitz individual pieces as desired.



Photo 01

- Cut five 16-inch length pieces of ribbon. Width – your choice – anywhere from ½" wide to 1 ½" wide.
- Align two sections with the eyelets on top of each other.
- Lace the ribbon through the eyelets from the front to the back. Photo 02



Photo 02

- Bring both ends of ribbon back through the center eyelets through the center eyelets.
Photo 03
- Tie ends into a bow. Photo 04



Photo 03



Photo 04

- Continue until all five wreath pieces are tied with ribbon.
- Trim the ribbon length to desired length.
- Pull the loops on the center banner through the eyelets on the wreath. Photo 05



Photo 05