

Note: Some designs in this collection may have been created using unique special stitches and/or techniques. To preserve design integrity when rescaling or rotating designs in your software, always rescale or rotate designs using the handles directly on-screen.



82006-01 Jumbo Floral Swirls Appliqué with Tufted Satins
7.83 X 9.15 in.
198.88 X 232.41 mm
45,725 St. ⚡ L



82006-02 Large Oval Floral Swirls
5.07 X 8.08 in.
128.78 X 205.23 mm
34,916 St. ⚡ L



82006-03 Floral Swirls Appliqué 1
4.52 X 6.87 in.
114.81 X 174.50 mm
28,031 St. ⚡ L



82006-04 Floral Swirls Appliqué 2
4.92 X 6.62 in.
124.97 X 168.15 mm
26,086 St. ⚡ L



82006-05 Floral Swirls Appliqué 3
3.82 X 5.05 in.
97.03 X 128.27 mm
16,825 St. ⚡ L



82006-06 Floral Swirls Appliqué 4
4.86 X 6.47 in.
123.44 X 164.34 mm
29,753 St. ⚡ L



82006-07 Floral Swirls 5
4.87 X 6.52 in.
123.70 X 165.61 mm
22,905 St. ⚡ L



82006-08 Floral Swirls 6
2.76 X 3.82 in.
70.10 X 97.03 mm
11,317 St.



82006-09 Floral Swirls 7
4.25 X 4.40 in.
107.95 X 111.76 mm
10,458 St.



82006-10 Floral Swirls 8
4.26 X 4.08 in.
108.20 X 103.63 mm
12,519 St.



82006-11 Floral Swirls 9
4.14 X 5.84 in.
105.16 X 148.34 mm
18,278 St. ⚡ L



82006-12 Swirls 1
3.19 X 3.94 in.
81.03 X 100.08 mm
5,051 St.

⚡ Design contains a loose fill.

⚡ Some white areas shown are not stitched.

L Design is larger than 5" (127 mm) in either direction.

S Design is smaller than 1.5" (38.1 mm) in either direction.

It is a violation of Copyright law to make and distribute copies of electronic designs or artwork.

Electronic designs are licensed to the original purchaser for use at one location. ©2013 Benartex Studios. All rights reserved.

Note: Some designs in this collection may have been created using unique special stitches and/or techniques. To preserve design integrity when rescaling or rotating designs in your software, always rescale or rotate designs using the handles directly on-screen.

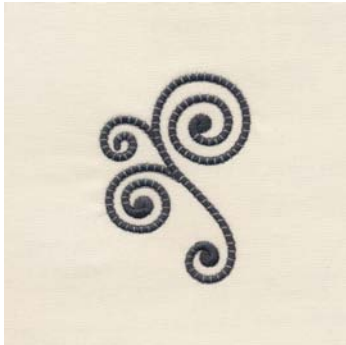

82006-13 Swirls 2
2.11 X 2.96 in.
53.59 X 75.18 mm
3,503 St.



82006-14 Leaf Appliqué
2.97 X 3.82 in.
75.44 X 97.03 mm
7,037 St.



82006-15 Three Mini Flowers
3.93 X 4.82 in.
99.82 X 122.43 mm
22,237 St.

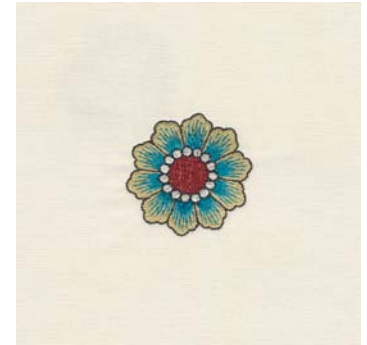

82006-16 Mini Flower 1
1.75 X 1.74 in.
44.45 X 44.20 mm
6,230 St.



82006-17 Mini Flower 2
1.40 X 1.46 in.
35.56 X 37.08 mm
3,216 St. **S**



82006-18 Mini Flower 3
1.50 X 1.63 in.
38.10 X 41.40 mm
3,321 St.



82006-19 Flower Appliqué with Tufted Satins 1
5.00 X 4.36 in.
127.00 X 110.74 mm
15,345 St.



82006-20 Flower Appliqué with Tufted Satins 2
4.95 X 4.44 in.
125.73 X 112.78 mm
19,562 St.



82006-21 Flower Appliqué 3
3.86 X 3.37 in.
98.04 X 85.60 mm
12,418 St.



82006-22 Little Medallion Flower Appliqué with Tufted Satins
2.87 X 2.73 in.
72.90 X 69.34 mm
10,509 St. **⌘**



82006-23 Large Medallion Appliqué with Tufted Satins
4.87 X 4.87 in.
123.70 X 123.70 mm
24,671 St.

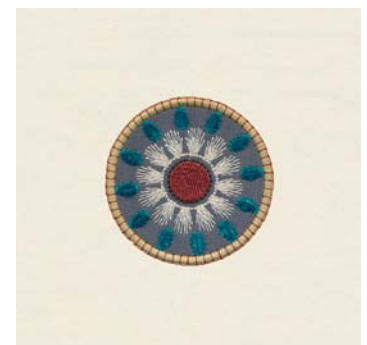

82006-24 Circle Appliqué with Tufted Satins
2.38 X 2.38 in.
60.45 X 60.45 mm
5,738 St.

⌘ Design contains a loose fill.

⚙ Some white areas shown are not stitched.

L Design is larger than 5" (127 mm) in either direction.

S Design is smaller than 1.5" (38.1 mm) in either direction.

It is a violation of Copyright law to make and distribute copies of electronic designs or artwork.

Electronic designs are licensed to the original purchaser for use at one location. ©2013 Benartex Studios. All rights reserved.

Note: Some designs in this collection may have been created using unique special stitches and/or techniques. To preserve design integrity when rescaling or rotating designs in your software, always rescale or rotate designs using the handles directly on-screen.



82006-25 Jumbo Floral Centerpiece Appliqué with Tufted Satins
9.61 X 9.28 in.
244.09 X 235.71 mm
68,690 St. ⚡ L



82006-26 Branch 1
2.80 X 3.45 in.
71.12 X 87.63 mm
5,869 St.



82006-27 Branch 2
2.45 X 2.21 in.
62.23 X 56.13 mm
3,254 St.



82006-28 Paisley Appliqué with Tufted Satins 1
3.19 X 4.85 in.
81.03 X 123.19 mm
13,285 St.



82006-29 Paisley Appliqué with Tufted Satins 2
4.14 X 4.63 in.
105.16 X 117.60 mm
14,390 St.



82006-30 Paisley Appliqué 3
3.93 X 6.87 in.
99.82 X 174.50 mm
21,657 St. L

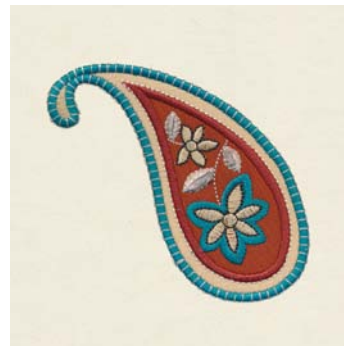

82006-31 Paisley Appliqué with Tufted Satins 4
3.51 X 3.22 in.
89.15 X 81.79 mm
7,229 St.

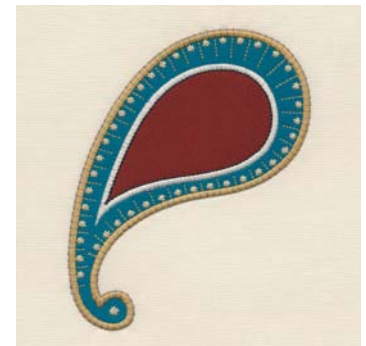

82006-32 Blank Paisley Appliqué
4.25 X 5.29 in.
107.95 X 134.37 mm
7,494 St. L



82006-33 Branch for Paisley
2.50 X 1.93 in.
63.50 X 49.02 mm
3,554 St.



82006-34 Flower for Paisley
2.15 X 1.71 in.
54.61 X 43.43 mm
3,960 St.



82006-35 Linework for Paisley
2.37 X 1.78 in.
60.20 X 45.21 mm
1,881 St. ⚡⚡



82006-36 Fancy Swirls Medallion Appliqué with Tufted Satins
4.79 X 4.84 in.
121.67 X 122.94 mm
21,967 St. ⚡

⚡ Design contains a loose fill.

⚡ Some white areas shown are not stitched.

L Design is larger than 5" (127 mm) in either direction.

S Design is smaller than 1.5" (38.1 mm) in either direction.

Note: Some designs in this collection may have been created using unique special stitches and/or techniques. To preserve design integrity when rescaling or rotating designs in your software, always rescale or rotate designs using the handles directly on-screen.



82006-37 Fancy Swirls Border
6.02 X 1.33 in.
152.91 X 33.78 mm
9,532 St. ⚡ L S



82006-38 Fancy Swirls Border Piece
1.52 X 1.33 in.
38.61 X 33.78 mm
2,367 St. ⚡ S



82006-39 Fancy Swirls Corner
2.70 X 2.70 in.
68.58 X 68.58 mm
5,491 St. ⚡

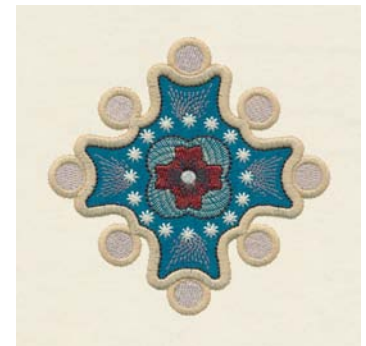

82006-40 Diamond Appliqué 1
3.79 X 3.79 in.
96.27 X 96.27 mm
10,582 St.



82006-41 Diamond Appliqué 2
3.37 X 3.38 in.
85.60 X 85.85 mm
8,362 St.



82006-42 Medallion Linework
4.87 X 4.87 in.
123.70 X 123.70 mm
11,433 St. ⚡ ⚡



82006-43 Paisley Linework
5.55 X 2.93 in.
140.97 X 74.42 mm
7,576 St. ⚡ ⚡ L



82006-44 Floral Linework 1
4.47 X 5.48 in.
113.54 X 139.19 mm
8,941 St. ⚡ ⚡ L



82006-45 Floral Linework 2
3.93 X 5.00 in.
99.82 X 127.00 mm
6,434 St. ⚡ ⚡



82006-46 Floral Linework 3
4.39 X 4.45 in.
111.51 X 113.03 mm
5,967 St. ⚡ ⚡



82006-47 Floral Linework 4
2.82 X 3.00 in.
71.63 X 76.20 mm
3,063 St. ⚡ ⚡

⚡ Design contains a loose fill.

⚡ Some white areas shown are not stitched.

L Design is larger than 5" (127 mm) in either direction.

S Design is smaller than 1.5" (38.1 mm) in either direction.

It is a violation of Copyright law to make and distribute copies of electronic designs or artwork.

Electronic designs are licensed to the original purchaser for use at one location. ©2013 Benartex Studios. All rights reserved.

Listings below indicate color sample, stitching order and suggested thread color number. Most numbers indicate Isacord thread. However, colors beginning with 20501 refer to YLI Fine Metallics, 7 refer to Yenmet Metallic, 8 refer to YLI Variations Variegated Thread and 9 refer to Isacord Multicolor Variegated.

82006-01 Jumbo Floral Swirls Appliqué with Tufted Satins

1. Black Vines.....	4174
2. Vine Linework.....	0108
3. Tan Spots.....	0771
4. Leaf Placement Stitch.....	0643
5. Leaf Cut Line & Tackdown.....	0643
6. Outer Paisley Placement Stitch.....	4421
7. Outer Paisley Cut Line & Tackdown.....	4421
8. Inner Paisley Placement Stitch.....	1526
9. Inner Paisley Cut Line & Tackdown.....	1526
10. Leaf Cover Stitch & Tan Details.....	0643
11. Large Flower Placement Stitch.....	0151
12. Large Flower Cut Line & Tackdown.....	0151
13. Flower Center Placement Stitch.....	0660
14. Flower Center Cut Line & Tackdown.....	0660
15. Leaf & Flower Details.....	0108
16. Paisley Flowers.....	0771
17. Outer Paisley Cover Stitch & Blue Details.....	4421
18. Inner Paisley Cover Stitch & Red Stamens.....	1526
19. Large Flower Cover Stitch, Details & Tufted Satins.....	0151
20. Flower Center Cover Stitch & Cream Shading.....	0660
21. Small Flowers Shading.....	0832
22. Small Flowers Stamen.....	4421
23. Design Outlines.....	4174

82006-02 Large Oval Floral Swirls

1. Black Vines.....	4174
2. Vine Linework.....	0108
3. Tan Spots.....	0771
4. Blue Petals.....	4421
5. Leaves.....	0643
6. Small Cream Petals.....	0660
7. Leaf Cream Shading.....	0660
8. Large Cream Petals.....	0660
9. Orange Flower Shading & Detail.....	0832
10. Large Tan Flower.....	0643
11. Large Flower Blue Shading.....	4421
12. Red Stamens.....	1526
13. Yellow Flowers Stamen Shading.....	4421
14. Large Flower Stamen Shading.....	0660
15. Design Outlines.....	4174

82006-03 Floral Swirls Appliqué 1

1. Black Vine.....	4174
2. Leaf Placement Stitch.....	0108
3. Leaf Cut Line & Tackdown.....	0108
4. Large Leaf Spots & Inner Designs.....	0771
5. Leaf Cover Stitch & Vine Linework.....	0108
6. Small Flower & Small Leaves.....	0643
7. Small Flower Blue Shading.....	4421
8. Small Flower Stamen.....	1526
9. Large Flower Placement Stitch.....	0151
10. Large Flower Cut Line & Tackdown.....	0151
11. Stamen Placement Stitch.....	0660
12. Stamen Cut Line & Tackdown.....	0660
13. Large Flower Blue Stamen Shading.....	4421
14. Gray Stamen Shading.....	0108
15. Cream Details.....	0660
16. Large Flower Spots.....	0771
17. Large Flower Cover Stitch.....	0151
18. Stamen Cover Stitch.....	0660
19. Design Outlines & Linework.....	4174

82006-04 Floral Swirls Appliqué 2

1. Black Vines.....	4174
2. Vine Linework.....	0108
3. Flower Outer Placement Stitch.....	0643
4. Flower Outer Cut Line & Tackdown.....	0643
5. Flower Center Placement Stitch.....	0660
6. Flower Center Cut Line & Tackdown.....	0660
7. Leaf Placement Stitch.....	0643
8. Leaf Cut Line & Tackdown.....	0643
9. Spots.....	0771
10. Large Flower & Leaf Blue Shading.....	4421
11. Flower, Leaf Cover Stitch & Leaves.....	0643
12. Flower Center Cover Stitch & Details.....	0660
13. Small Flowers Shading.....	0832
14. Red Stamens.....	1526
15. Small Flower Stamen Details.....	4421
16. Design Outlines.....	4174

82006-05 Floral Swirls Appliqué 3

1. Black Vines.....	4174
2. Vine Linework.....	0108
3. Leaves.....	0643
4. Leaf Shading.....	0660
5. Top Placement Stitch.....	0151
6. Top Cut Line & Tackdown.....	0151
7. Bottom Placement Stitch.....	0771
8. Bottom Cut Line & Tackdown.....	0771
9. Bottom Cover Stitch, Shading & Shading.....	0771
10. Cream Linework.....	0660
11. Center Placement Stitch.....	0151
12. Center Cut Line & Tackdown.....	0151
13. Blue Stamen.....	4421
14. Top & Center Cover Stitch.....	0151
15. Top Cover Stitch Linework.....	0108
16. Black Linework & Shading.....	4174

82006-06 Floral Swirls Appliqué 4

1. Leaf.....	0643
2. Leaf Shading.....	0660
3. Black Vine & Leaf Outline.....	4174
4. Vine Linework.....	0108
5. Tan Spots.....	0771
6. Small Flower Petals.....	4421
7. Small Cream Petals.....	0660
8. Small Flower Stamens.....	1526
9. Large Outer Petals Placement Stitch.....	0643
10. Large Outer Petal Cut Line & Tackdown.....	0643
11. Center Petals Placement Stitch.....	0660
12. Center Petals Cut Line & Tackdown.....	0660
13. Large Flower Red Shading.....	1526
14. Large Flower Blue Shading.....	4421
15. Large Flower Tan Shading.....	0771
16. Outer Petals Cover Stitch.....	0643
17. Center Petals Cover Stitch.....	0660
18. Cover Stitch Linework & Outlines.....	4174

82006-07 Floral Swirls 5

1. Black Vines.....	4174
2. Vine Linework.....	0108
3. Leaves.....	0643
4. Leaf Shading.....	0660
5. Flowers.....	0643
6. Flowers Shading.....	4421
7. Red Stamen.....	1526
8. White Stamen.....	0660
9. Design Outlines.....	4174

82006-08 Floral Swirls 6

1. Black Vines.....	4174
2. Vine Linework.....	0108
3. Leaves.....	0643
4. Leaf Shading.....	0660
5. Flower.....	0643
6. Flower Shading.....	4421
7. Red Stamen.....	1526
8. White Stamen.....	0660
9. Design Outlines.....	4174

82006-09 Floral Swirls 7

1. Black Vines.....	4174
2. Vine Linework.....	0108
3. Leaves.....	0643
4. Leaf Shading.....	0660
5. Flower.....	0660
6. Flower Details.....	0832
7. Red Stamen.....	1526
8. Blue Stamen.....	4421
9. Flower & Leaf Outlines.....	4174

82006-10 Floral Swirls 8

1. Black Vine.....	4174
2. Vine Linework.....	0108
3. Flowers.....	0660
4. Flower Details.....	0832
5. Red Stamen.....	1526
6. Blue Stamen.....	4421
7. Leaves.....	0643
8. Leaf Shading.....	0660
9. Design Outlines.....	4174

82006-11 Floral Swirls 9

1. Black Vines.....	4174
2. Vine Linework.....	0108
3. Tan Spots.....	0771
4. Blue Petals.....	4421
5. Cream Petals.....	0660
6. Flower Outlines.....	4174
7. Stamens.....	1526

82006-12 Swirls 1

1. Black Vines.....	4174
2. Vine Linework.....	0108

82006-13 Swirls 2

1. Black Vines.....	4174
2. Vine Linework.....	0108

82006-14 Leaf Appliqué

1. Placement Stitch.....	0108
2. Cut Line & Tackdown.....	0108
3. Tan Spots.....	0771
4. Blue Details.....	4421
5. Cover Stitch.....	0108
6. Cover Stitch Linework & Outlines.....	4174

82006-15 Three Mini Flowers

1. Leaves.....	0643
2. Leaf Shading.....	0660
3. Flowers.....	0643
4. Flower Shading.....	4421
5. Red Stamen.....	1526
6. Cream Stamen.....	0660
7. Design Outlines.....	4174

Listings below indicate color sample, stitching order and suggested thread color number. Most numbers indicate Isacord thread. However, colors beginning with 20501 refer to YLI Fine Metallics, 7 refer to Yenmet Metallic, 8 refer to YLI Variations Variegated Thread and 9 refer to Isacord Multicolor Variegated.

82006-16 Mini Flower 1

1. Flower	0643
2. Flower Shading	4421
3. Red Stamen	1526
4. Cream Stamen	0660
5. Design Outlines	4174

82006-17 Mini Flower 2

1. Flower	0660
2. Flower Details	0832
3. Red Stamen	1526
4. Blue Stamen	4421
5. Design Outlines	4174

82006-18 Mini Flower 3

1. Tan Spots	0771
2. Blue Petals	4421
3. Cream Petals	0660
4. Design Outlines	4174
5. Red Stamen	1526

82006-19 Flower Appliqué with Tufted Satins 1

1. Outer Placement Stitch	0771
2. Outer Cut Line & Tackdown	0771
3. Center Placement Stitch	0660
4. Center Cut Line & Tackdown	0660
5. Blue Shading	4421
6. Outer Cover Stitch, Spots & Tan Shading	0771
7. Orange Shading	0832
8. Center Cover Stitch, Tufted Satins & Details	0660
9. Cover Stitch Linework	4174

82006-20 Flower Appliqué with Tufted Satins 2

1. Outer Placement Stitch	0771
2. Outer Cut Line & Tackdown	0771
3. Inner Placement Stitch	0151
4. Inner Cut Line & Tackdown	0151
5. Blue Linework	4421
6. Outer Cover Stitch & Spots	0771
7. Orange Shading	0832
8. Red Stamen	1526
9. Tufted Satins & Cream Shading	0660
10. Inner Cover Stitch	0151
11. Cover Stitch Linework	4174

82006-21 Flower Appliqué 3

1. Top Placement Stitch	0151
2. Top Cut Line & Tackdown	0151
3. Bottom Placement Stitch	0771
4. Bottom Cut Line & Tackdown	0771
5. Bottom Cover Stitch & Details	0771
6. Cream Shading	0660
7. Center Placement Stitch	0151
8. Center Cut Line & Tackdown	0151
9. Blue Stamen	4421
10. Top & Center Cover Stitch	0151
11. Top Cover Stitch Linework	0108
12. Black Linework & Shading	4174

82006-22 Little Medallion Flower Appliqué with

Tufted Satins

1. Outer Placement Stitch	4174
2. Outer Cut Line & Tackdown	4174
3. Inner Placement Stitch	4174
4. Inner Cut Line & Tackdown	4174
5. Red Flower	1526
6. Tan Shading & Spots	0771
7. Tufted Satins	0832
8. Cover Stitches	4174
9. Outer Cover Stitch Linework	0108
10. Inner Cover Stitch Linework & Flower	0660

82006-23 Large Medallion Appliqué with Tufted

Satins

1. Petal Medallion Placement Stitch	1526
2. Petal Medallion Cut Line & Tackdown	1526
3. Large Circle Placement Stitch	0108
4. Large Circle Cut Line & Tackdown	0108
5. Small Circle Placement Stitch	4174
6. Small Circle Cut Line & Tackdown	4174
7. Vine & Leaves	0771
8. Flowers & Inner Light Shading	0660
9. Flower Outlines	4174
10. Petal Medallion Cover Stitch	1526
11. Petal Medallion Cover Stitch Linework	0832
12. Large Circle Cover Stitch	0108
13. Small Circle Cover Stitch, Linework & Tufted Satins	4174

82006-24 Circle Appliqué with Tufted Satins

1. Medallion Placement Stitch	0643
2. Medallion Cut Line & Tackdown	0643
3. Tufted Satins	4421
4. Medallion Cover Stitch	0643
5. Cream Shading	0660
6. Red Center	1526
7. Design Outlines	4174

82006-25 Jumbo Floral Centerpiece Appliqué with

Tufted Satins

1. Gray Background Swirls	0151
2. Top Placement Stitch	0151
3. Flower Top Cut Line & Tackdown	0151
4. Flower Bottom Placement Stitch	0771
5. Flower Bottom Cut Line & Tackdown	0771
6. Medallions Oval Placement Stitch	4174
7. Medallions Oval Cut Line & Tackdown	4174
8. Medallions Inner Oval Placement Stitch	4174
9. Medallions Inner Oval Cut Line & Tackdown	4174
10. Flower Bottom Cover Stitch & Details	0771
11. Small Flowers & Tufted Satins	0832
12. Medallions Oval Cover Stitch & Details	4174
13. Medallions Oval Cover Stitch Linework	0108
14. Cream Details	0660
15. Flower Center Placement Stitch	0151
16. Flower Center Cut Line & Tackdown	0151
17. Blue Flower Stamen	4421
18. Flower Top & Center Cover Stitch	0151
19. Flower Top Cover Stitch Linework	0108
20. Flower Bottom Cover Stitch Linework	4174
21. Leaves	0643
22. Leaves Shading & Stamens	1526

82006-26 Branch 1

1. Leaves	0643
2. Leaf Shading	1526
3. Stem	0643

82006-27 Branch 2

1. Leaves	0643
2. Leaf Shading	1526
3. Stem	0643

82006-28 Paisley Appliqué with Tufted Satins 1

1. Placement Stitch	1526
2. Cut Line & Tackdown	1526
3. Orange Shading	0832
4. Diamonds	0771
5. Gray Linework	0108
6. Tufted Satins & Vines	4174
7. Cover Stitch	1526
8. Cover Stitch Linework	0151

82006-29 Paisley Appliqué with Tufted Satins 2

1. Paisley Placement Stitch	4421
2. Paisley Cut Line & Tackdown	4421
3. Inner Placement Stitch	0108
4. Inner Cut Line & Tackdown	0108
5. Paisley Cover Stitch, Blue Details & Tufted Satins	4421
6. Red Flowers	1526
7. Flower Shading	0832
8. Stamens	0660
9. Gray Triangle Border	0151
10. Inner Cover Stitch	0108
11. Inner Cover Stitch Linework	4174
12. Tan Spots	0771

82006-30 Paisley Appliqué 3

1. Outer Placement Stitch	0108
2. Outer Cut Line & Tackdown	0108
3. Inner Placement Stitch	0660
4. Inner Cut Line & Tackdown	0660
5. Spots & Leaves	0771
6. Orange Shading	0832
7. Outer Cover Stitch & Leaf Details	0108
8. Outer Cover Stitch Linework	4174
9. Inner Cover Stitch	0660
10. Inner Cover Stitch Linework	1526

82006-31 Paisley Appliqué with Tufted Satins 4

1. Outer Placement Stitch	4421
2. Outer Cut Line & Tackdown	4421
3. Inner Placement Stitch	1526
4. Inner Cut Line & Tackdown	1526
5. Tufted Satins & Stems	0151
6. Flowers & Shading	0771
7. Outer Cover Stitch & Blue Flower Shading	4421
8. Outer Cover Stitch Linework	0151
9. Inner Cover Stitch	1526
10. Inner Cover Stitch Linework	0660
11. Flower Outlines	4174

82006-32 Blank Paisley Appliqué

1. Outer Placement Stitch	0832
2. Outer Cut Line & Tackdown	0832
3. Inner Placement Stitch	0660
4. Inner Cut Line & Tackdown	0660
5. Inner Cover Stitch	0660
6. Inner Cover Stitch Linework	4174
7. Tan Spots	0771
8. Outer Cover Stitch	0832
9. Outer Cover Linework	0108

82006-33 Branch for Paisley

1. Leaves	0643
2. Leaf Shading	1526
3. Stem	0643

82006-34 Flower for Paisley

1. Black Vine	4174
2. Vine Linework	0108
3. Flower	0660
4. Orange Flower Details	0832
5. Red Stamen	1526
6. Blue Stamen	4421
7. Design Outlines	4174

82006-35 Linework for Paisley

1. Single Color Design	0832
------------------------	------

Listings below indicate color sample, stitching order and suggested thread color number. Most numbers indicate Isacord thread. However, colors beginning with 20501 refer to YLI Fine Metallics, 7 refer to Yenmet Metallic, 8 refer to YLI Variations Variegated Thread and 9 refer to Isacord Multicolor Variegated.

82006-36 Fancy Swirls Medallion Appliqué with Tufted Satins

1. Placement Stitch	4174
2. Cut Line & Tackdown	4174
3. Tufted Satins	4421
4. Cream Shading	0660
5. Orange Center	0832
6. Cover Stitch & Center Outline	4174
7. Cover Stitch Linework	0108
8. Outer Swirl Border	4421

82006-37 Fancy Swirls Border

1. Single Color Design	4421
------------------------------	------

82006-38 Fancy Swirls Border Piece

1. Single Color Design	4421
------------------------------	------

82006-39 Fancy Swirls Corner

1. Single Color Design	4421
------------------------------	------

82006-40 Diamond Appliqué 1

1. Placement Stitch	0771
2. Cut Line & Tackdown	0771
3. Gray Spots	0151
4. Dark Gray Shading	0108
5. Cover Stitch & Inner Tan Shading	0771
6. Red Flower	1526
7. Black Shading & Linework	4174
8. Cream Spots & Center	0660

82006-41 Diamond Appliqué 2

1. Placement Stitch	0771
2. Cut Line & Tackdown	0771
3. Inner Cream Shading	0660
4. Blue Spots & Inner Shading	4421
5. Flower	1526
6. Stamen	0660
7. Cover Stitch	0771
8. Cover Stitch Linework	4174

82006-42 Medallion Linework

1. Gray Linework	0108
2. Red Linework	1526
3. Blue Linework	4421

82006-43 Paisley Linework

1. Gray Linework	0108
2. Flower & Leaves	0832
3. Red Linework	1526

82006-44 Floral Linework 1

1. Red Linework	1526
2. Orange Linework	0832
3. Gray Linework	0108

82006-45 Floral Linework 2

1. Leaves & Vine	0832
2. Blue Flower Petals	4421
3. Gray Flower	0108

82006-46 Floral Linework 3

1. Flowers	1526
2. Leaves & Vines	0832
3. Gray Linework	0108

82006-47 Floral Linework 4

1. Leaves & Vine	0832
2. Flower	1526
3. Gray Linework	0108

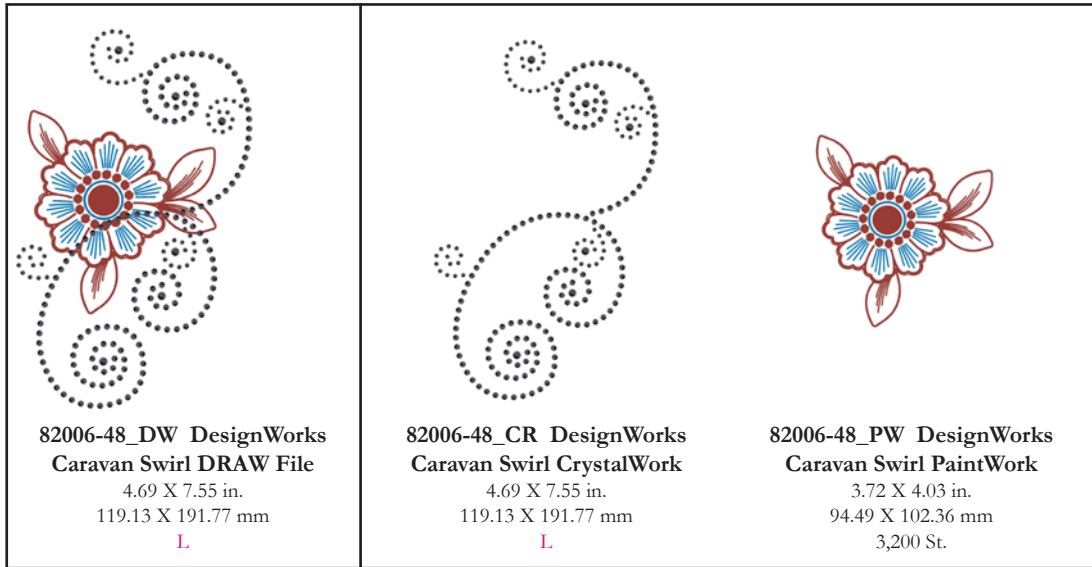

82006-48_CR DesignWorks Caravan Swirl CrystalWork

- 1. Size SS6 (61 Rhinestones)..... Jet
- 2. Size SS10 (154 Rhinestones)..... Jet
- 3. Size SS16 (6 Rhinestones)..... Jet

82006-48_PW DesignWorks Caravan Swirl PaintWork

- 1. Brown Details.....4600-7
- 2. Blue Details.....4600-3

NOTE: Paint colors listed (beginning with 4600) refer to Edding Textile Pens, style 4600. The number following 4600 is the recommended pen color.

GENERAL INSTRUCTIONS FOR USING MULTIPLE DESIGNWORKS COMPONENTS IN ONE DESIGN:

1. Refer to the color information bar on your machine or your design instructions to determine the order in which you use traditional machine embroidery (needle and thread) or the PaintWork tool. PaintWork files are denoted by _PW at the end of a file name.
2. Create any CrystalWork templates using the CrystalWork files and the CrystalWork tool following the CrystalWork Instructions. These files are denoted by _CR at the end of the file name. The templates can be created either before or after the design is stitched, but the crystals will be applied after the embroidery and/or paint is completed.

CRYSTALWORK INSTRUCTIONS:

1. Remove upper thread from the machine.
2. Attach the Straight Stitch/CutWork Stitch Plate for your machine.
3. Remove the needle and replace with the correct size punch tool (SS6, SS10, SS12, SS16 as noted on the Color Bar of the machine or in the crystal chart for the design collection) with the flat side toward the back. Tighten the needle clamp.
4. Attach Presser Foot #48.
5. Place the CrystalWork container on the stitch plate with the center positioning pin in the rear hole of the stitch plate.
6. Attach the punch plate (same size as the punch tool used) on top of the container so that it sits flush with the top.
7. Lower the punch tool by turning the handwheel to check that the container lines up correctly. **See Photo 1**
8. Hoop parchment paper up-side down and trim all excess from edges. **See Photos 2 and 3**
9. Cut a piece of rhinestone template material slightly larger than the design. Remove backing from the template material and place the sticky side down on the top of the parchment paper in the center of the hoop. **See Photo 4**
10. Place hoop on machine and use your machine's check feature to ensure that the template material is positioned correctly. Punch the first color change.

Note: The machine will prompt when the container is full and needs to be emptied. However, you may also wish to empty the container between color changes. ANY time you remove the container for cleaning, be sure to repeat Step 7 to ensure that the container is positioned properly. Check the back of the parchment paper between color changes also to remove any stray dots that may be stuck to the paper.

11. If more than one size crystal is used in the design, replace the punch tool and the punch plate on the top of the container with sizes to correspond with the size shown on the Color Bar of the machine. Repeat this process as needed until the design is finished. **See Photo 5**
12. Carefully peel the rhinestone template material away from the parchment paper and place on a piece of rhinestone template backboard. Smooth into place.
13. Pour the largest size of crystals used in the design over the template and use a small rhinestone brush to push them into place. **See Photos 6 and 7**
14. Make sure that all holes of that size are filled, and that all crystals are facing upright.
15. Repeat Steps 13 and 14 for any additional sizes, continuing with the next largest size and progressing to the smallest size.
16. Once all holes in the template are filled with the correct size crystals, check to ensure that all crystals are facing up and that there are no stray crystals. **See Photo 8**

Note: Design pictured is for instructional purposes and is not included in this collection.

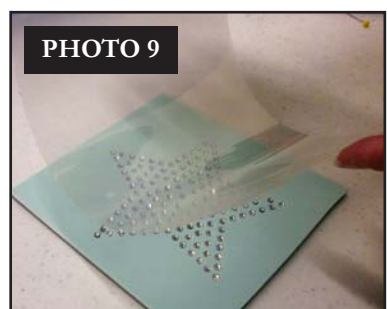
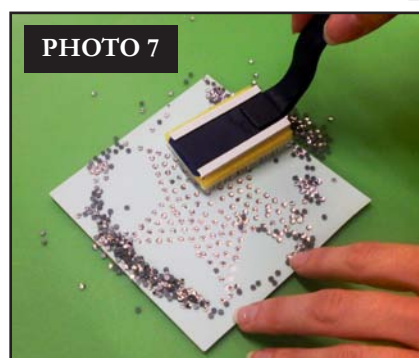
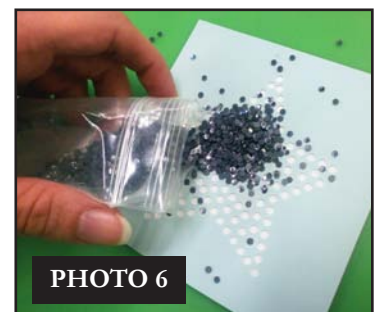
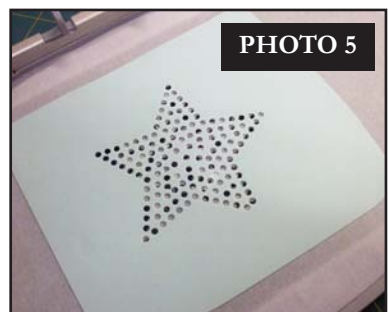

17. Cut a piece of rhinestone application tape slightly larger than the design.
18. Remove the backing and place tape sticky side down over the crystal template. **See Photo 9**
19. Smooth application tape over the top of each crystal using your fingertips or the rhinestone brush to ensure that all crystals are adhered to the tape.
20. Slowly peel transfer tape away from the template. The crystals should come up adhered to the tape. **See Photo 10** If individual crystals are loose or missing, lay the tape carefully back down and re-adhere crystals.
21. Position the transfer tape with the crystals sticky side down onto your project. **See Photo 11**
22. Place a press cloth over the transfer tape and press firmly with a hot iron for approximately 15 seconds. If the transfer is larger than the iron, move the iron to another area and repeat. NOTE: Time and temperature given here are meant as guidelines only. Refer to instructions from the crystal manufacturer for best results.
23. Allow the transfer to cool completely before peeling the transfer tape away. **See Photo 12**

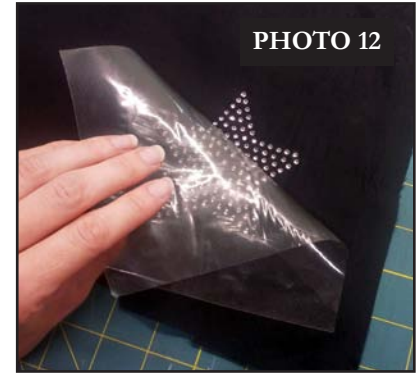
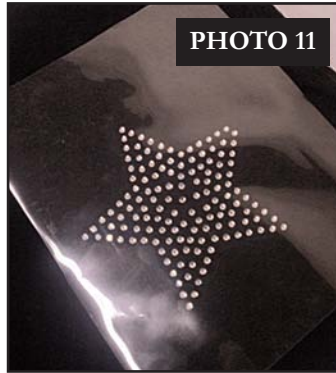

PAINTWORK INSTRUCTIONS

1. Remove the upper thread and needle from the machine.
2. Attach the Straight Stitch/CutWork Stitch Plate to the machine.
3. Open the clamping lever on the PaintWork tool and slide the appropriate pen adaptor into the shaft of the tool. Close the clamping lever.
4. Attach the PaintWork tool over the presser foot holder cone and secure with the lever.
5. Prior to hooping, iron the fabric to remove any wrinkles. The fabric must be smooth and hooped securely in order to ensure proper working of the tool.
6. Hoop your project using the appropriate stabilizing method.

Method A:

- a. Hoop a piece of Stabil-Stick Cut Away or Stabil-Stick Tear Away by itself in the hoop.
- b. Score and remove the paper.
- c. Place the fabric to be painted over the sticky surface with right side up. Gently smooth into position. For best results, the stabilizer should be adhered to as much area of the fabric as possible.

Method B

- a. Spray stabilizer of your choice with a generous amount of temporary spray adhesive.
 - b. Place the sprayed side of the stabilizer on the wrong side of the fabric. Hoop all layers as one unit.
7. Attach the hoop to the machine.
 8. Swing the pen guard down. Release the clamping lever and insert the appropriate pen with a slight twisting motion until the tip just touches the pen guard. Close the clamping lever. The pen should now be held firmly in place. NOTE: Although there should be some pressure against the pen as it is inserted, do not use excessive force without supporting the PaintWork tool.
 9. Swing the pen guard up and start painting using the Start / Stop button on the machine. NOTE: It is advisable to hoop a test piece of fabric to test for pen pressure prior to the painting on the actual project. An alternative to this is to cut a hoop sized piece of Stabil-Stick, remove the paper from the entire back, and place the Stabil-Stick over the hooped project. Start the machine and paint for a few seconds. Adjust the pen pressure as needed to achieve the look you desire. (**See Photo 1**) Turning the dial counter-clockwise decreases the pressure. Turning the dial clockwise increases the pressure. When you have achieved the desired effect, remove the Stabil-Stick from the top and re-start the design from the beginning.
 10. When the first color is finished, swing the pen guard down. Open the clamping lever and remove the pen.
 11. Clean the pen guard between color changes and allow fabric to dry between color changes to avoid mixing colors. **Tip:** To help guarantee colors will not mix, remove the hoop from the machine, but not the fabric from the hoop. Use a small, applique iron to heat the color. Replace the hoop and continue your design.
 12. Refer to the color information on the machine's screen and insert a second pen following steps above if needed. Tip: after raising the pen guard, wipe the tip of the pen with a white cloth before starting the color. **See Photo 2**
 13. Use an Iron to heat set the painted fabric following pen manufacturer's instructions.



General Tufted Satin Embroidery Instructions

1. Lay embroidered design flat.
2. Refer to the *Tufted Satin Embroidery Guides* on the following pages to determine which satins are to be cut.
3. With a craft knife, lightly slice through the satins. You may need to repeat slicing the satins until you have achieved the desired look while being careful not to cut the fabric.

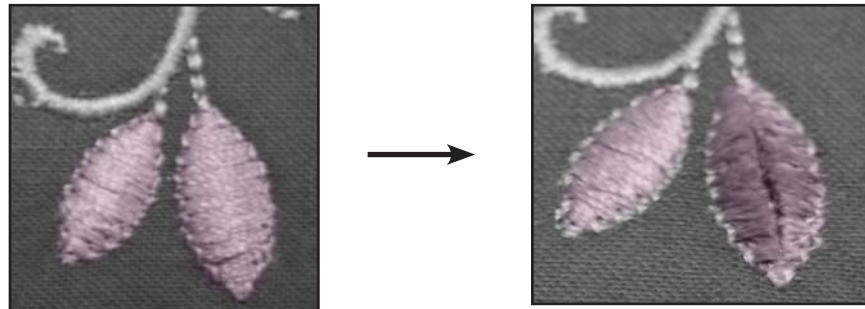

Tufted Satin Guides

Solid pink area denotes tufted satin cut areas.

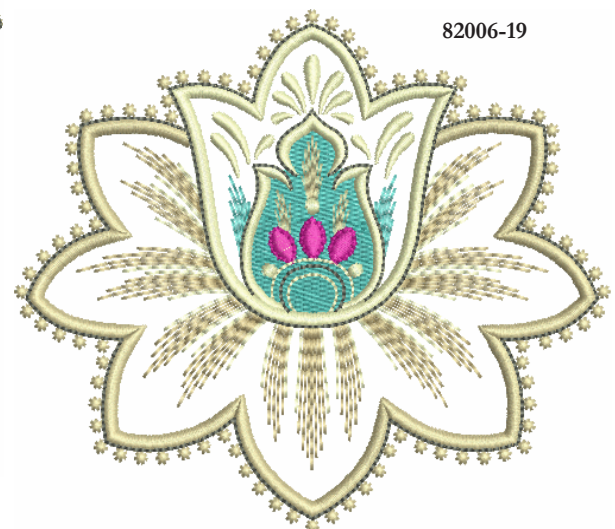



82006-20



82006-22

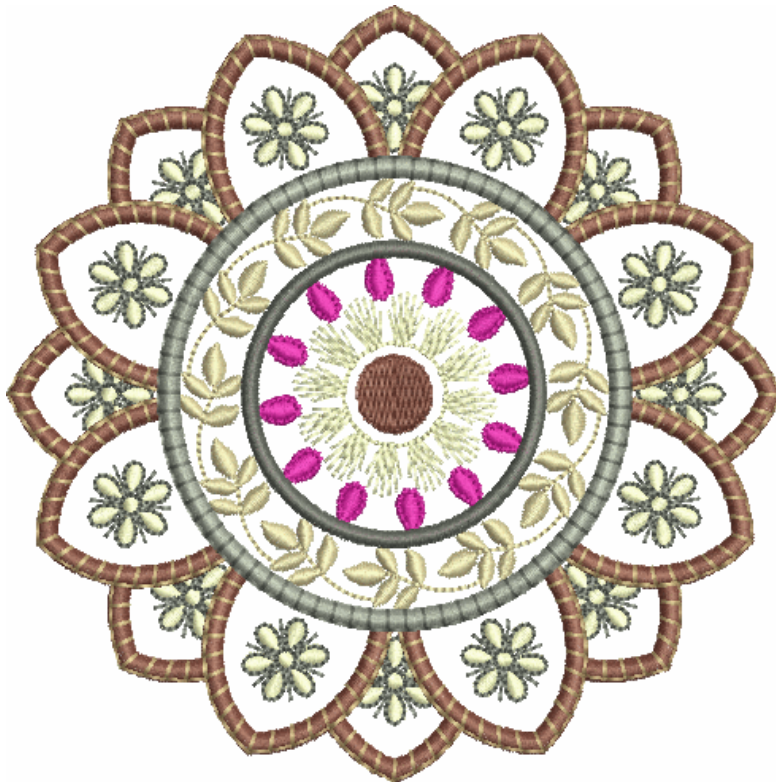

82006-23

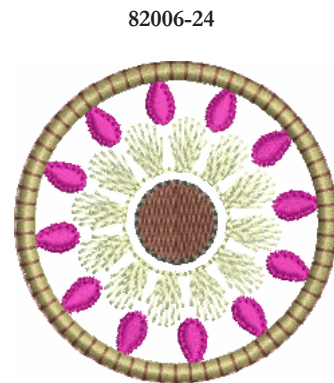

82006-24

82006-25

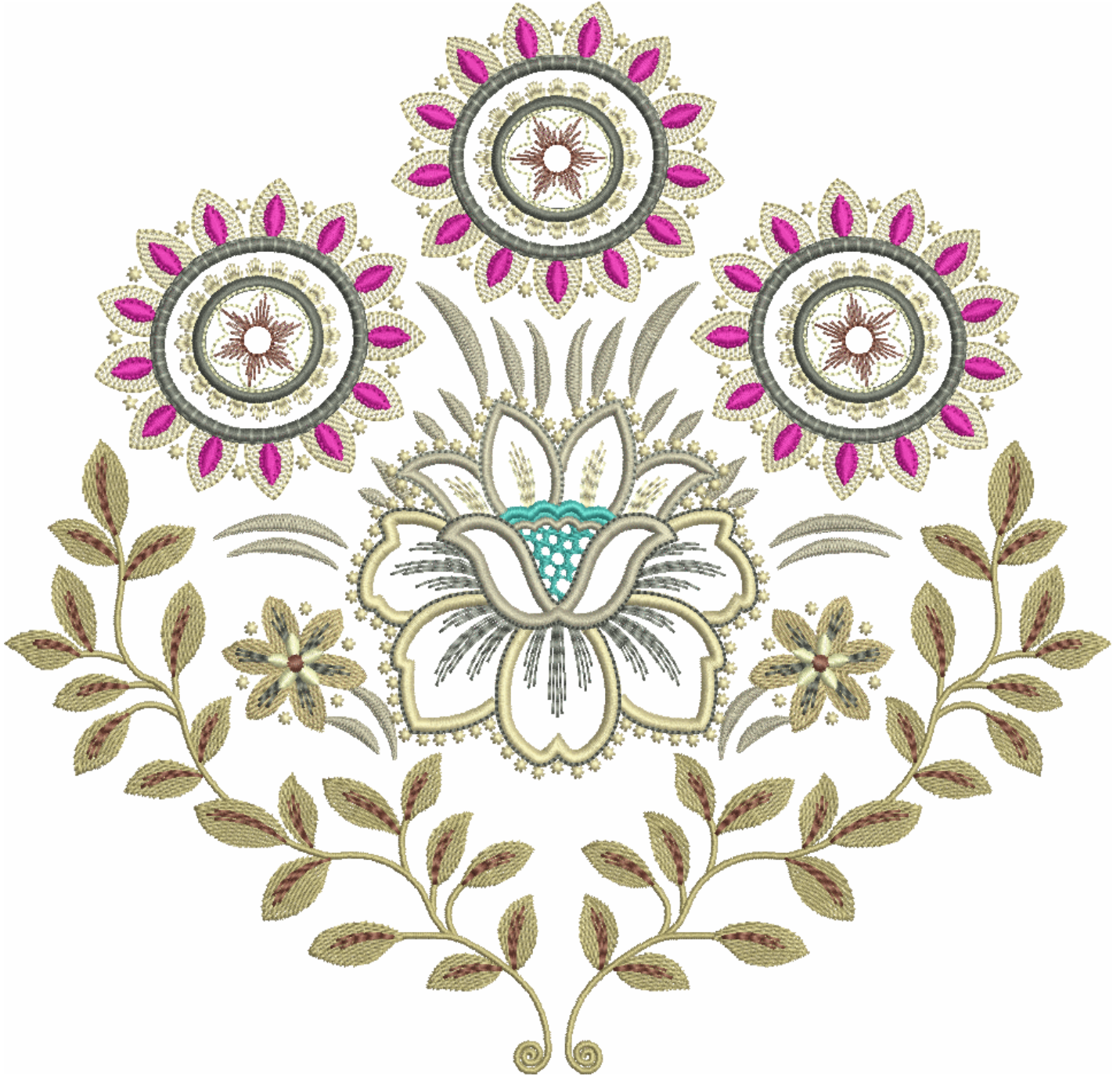

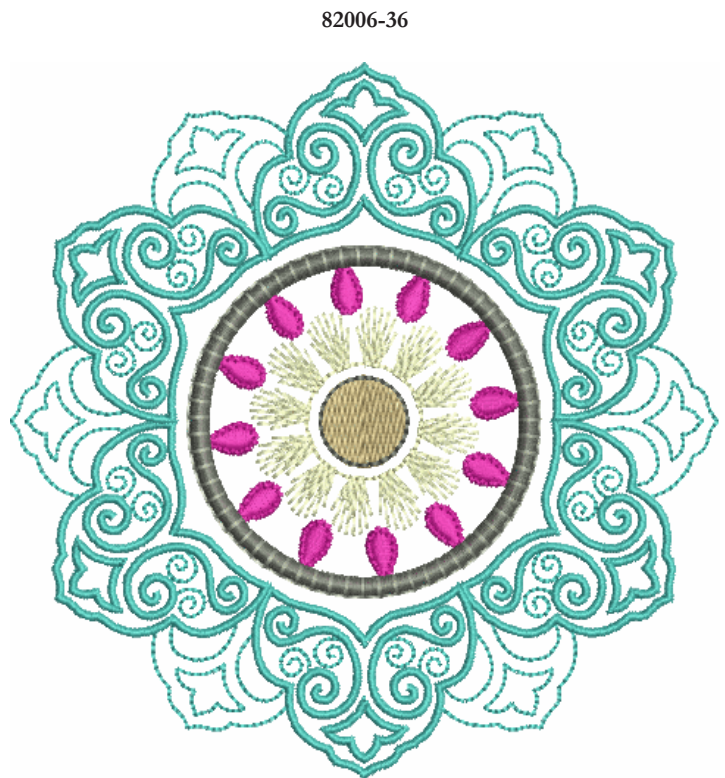
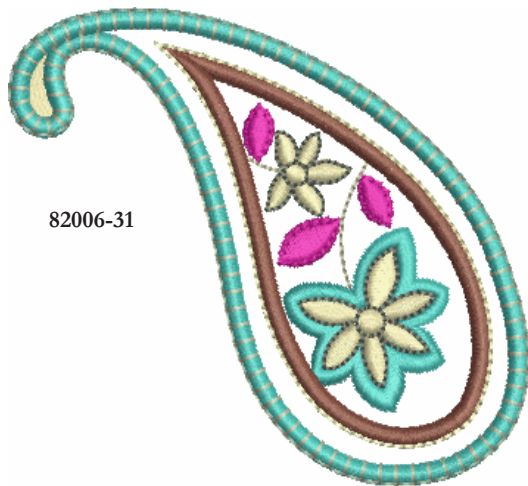
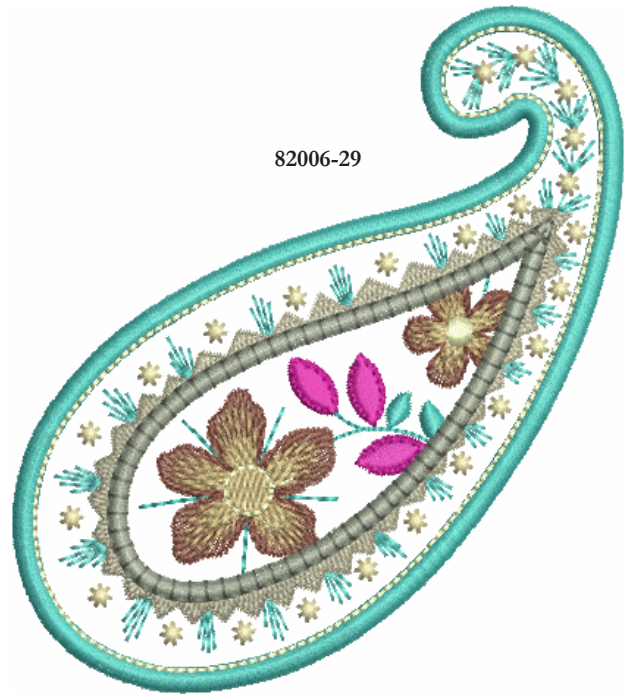
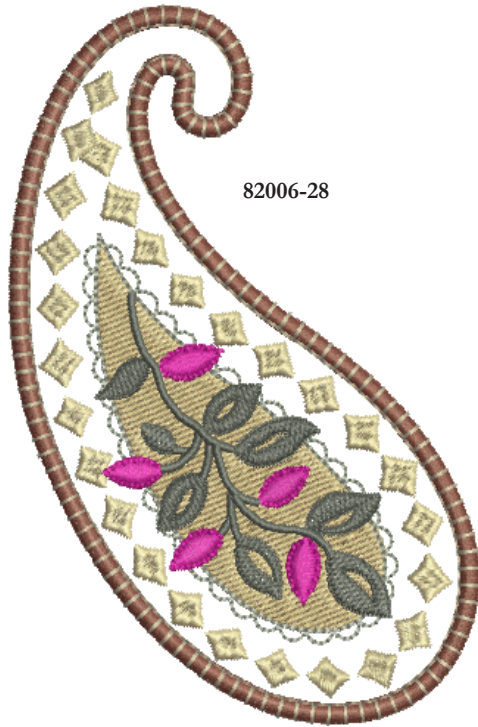

This printable design can be printed on printable fabric or heat transfer paper. This JPG design on the CD is ready for printing, just follow the manufacturer's instructions for printing and applying. WMF design format can be imported into BERNINA Embroidery Software 6 with CorelDRAW to design mixed media applications. Reference the CorelDRAW manual for tips on creating mixed media applications.

Caravan Printable



Appliqué Instructions

1. Print out the necessary pages from the PDF of the appliqué pattern(s).
2. Mark the right side of the pattern pieces so you'll know which direction to lay the pattern on the fabric.
3. Lightly spray the wrong side of the pattern pieces with temporary adhesive spray and allow it to set for a few minutes.
4. Place the pattern pieces on the right side of the fabric and carefully cut them out. **PHOTO 1**
5. Sew the placement stitch on your hooped fabric. **PHOTO 2**
6. With the paper still stuck to the right side of the appliqué fabric, spray the wrong side of the fabric with temporary spray adhesive.
7. Place the fabric inside the sewing placement stitch so that it matches the stitching line, and then remove the paper pattern. **PHOTO 3**
8. Sew the tackdown. **PHOTO 4**
9. Sew the remainder of the design and repeat for any remaining pieces. **PHOTO 5**

NOTE: The patterns are sized for the designs as they were made. If you resize the design, you will need to resize the pattern the same amount. You can print out the pattern at the normal size then copy it on a copy machine at the changed size. For example, resize the designs to 80%, resize the printed pattern to 80%.

TIP: When Printing the patterns, make sure that the "Fit to page" option is UNCHECKED in the Print Dialog Box. If this option is checked the printed patterns will not be actual size.

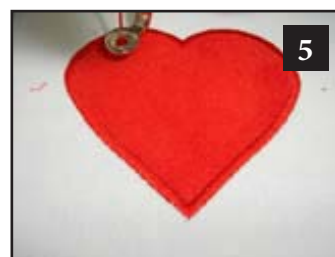
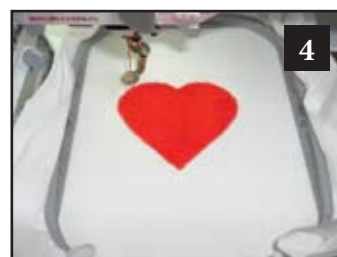
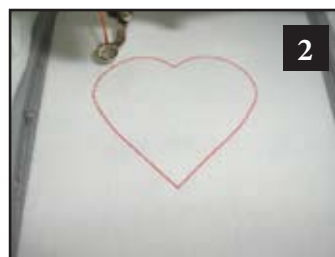

ATTENTION

When printing this document, any page scaling or page fitting options in your print dialog box must be turned OFF or set to NONE so that your files will print out at their actual size. Images not printed at actual size will not function as intended.

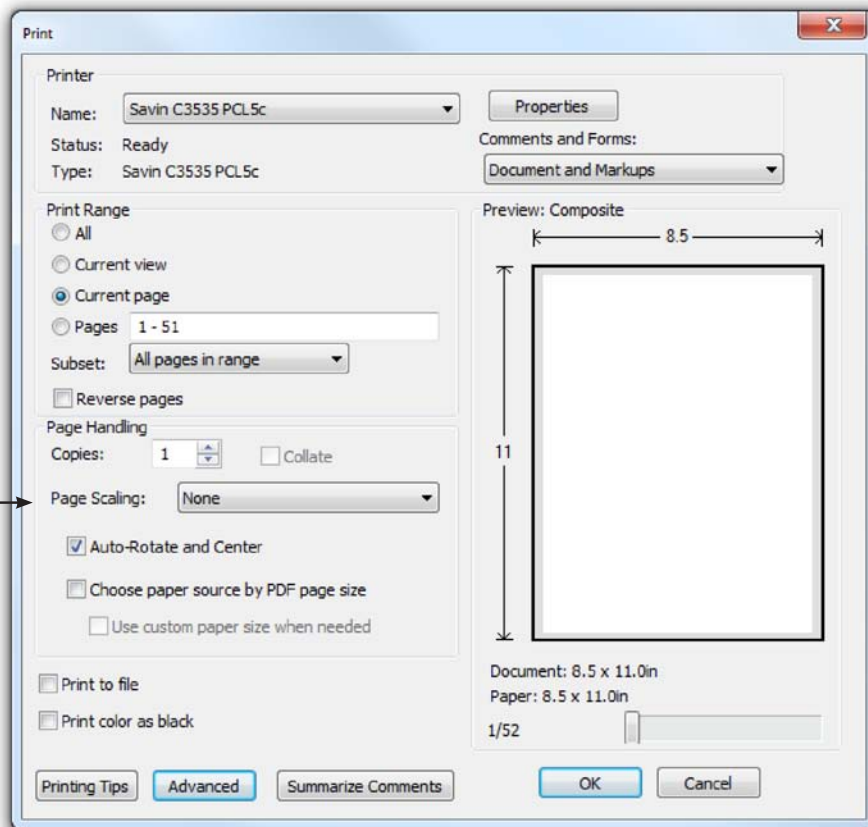

TO SAVE PAPER

Only print the desired image by navigating to the image's page, go to File > Print and select "Current page" in the print dialog box. Repeat for each desired image.

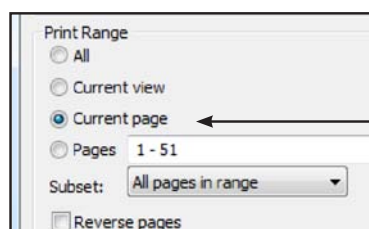

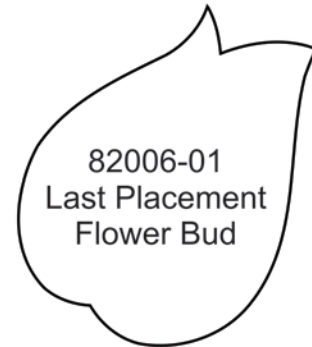
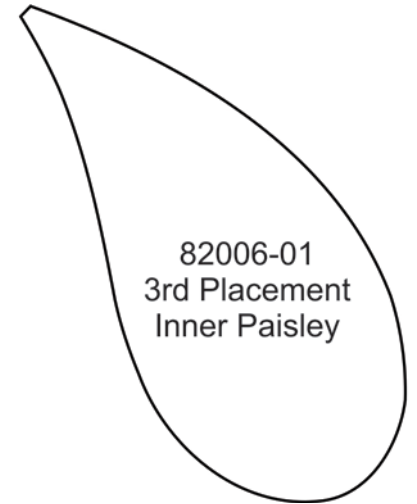
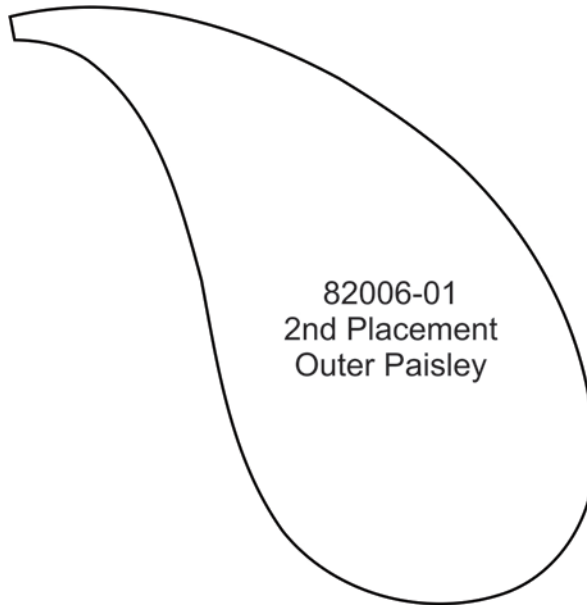

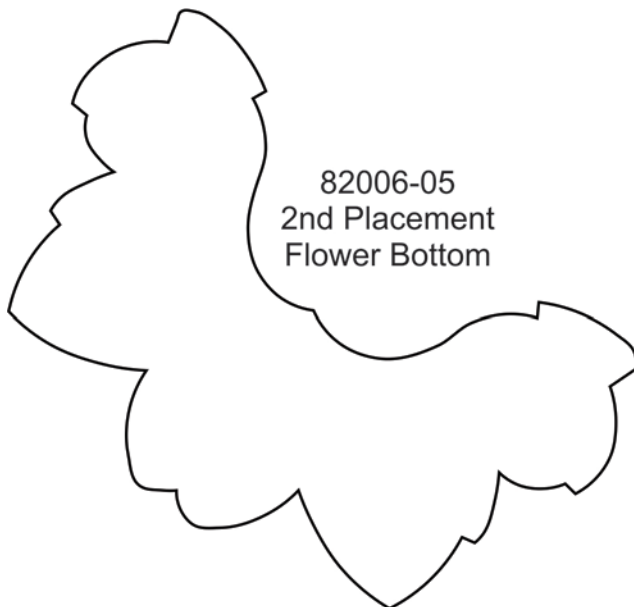
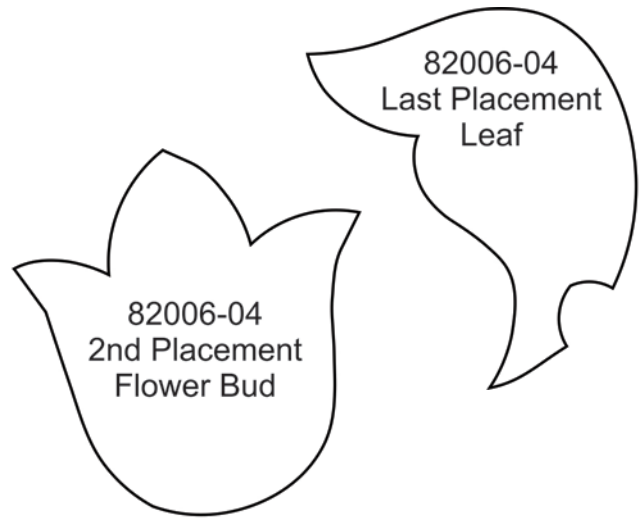
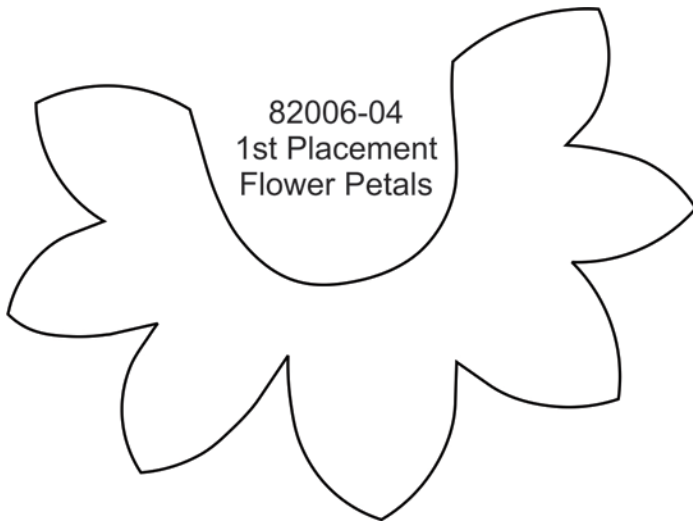

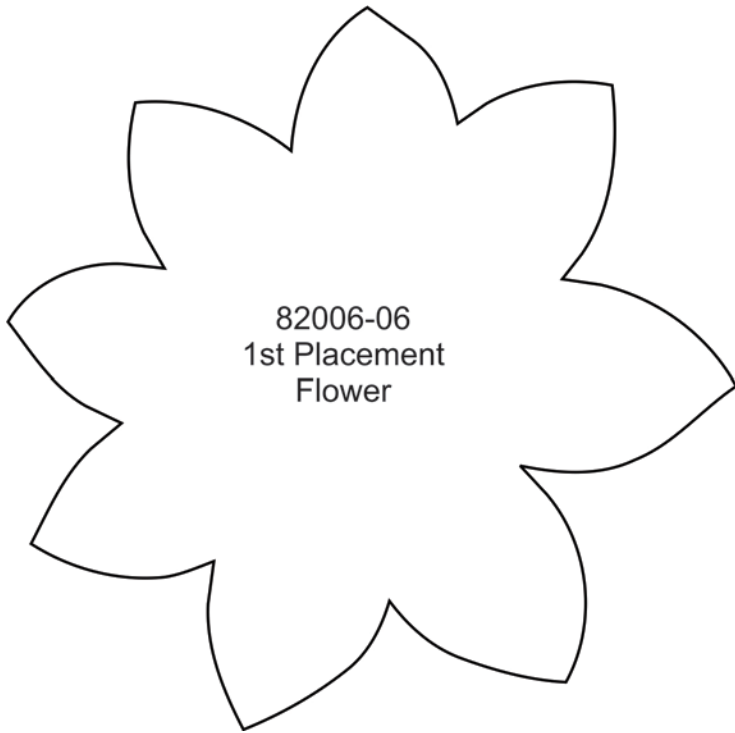

82006-06
1st Placement
Flower



82006-06
Last Placement
Flower Center

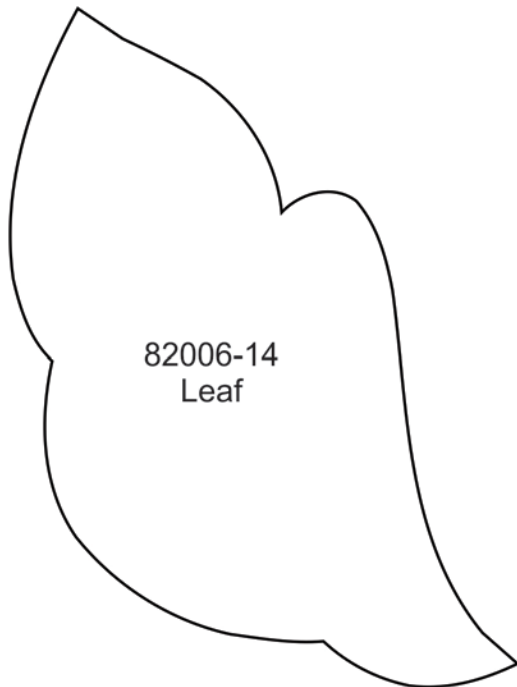

82006-14
Leaf

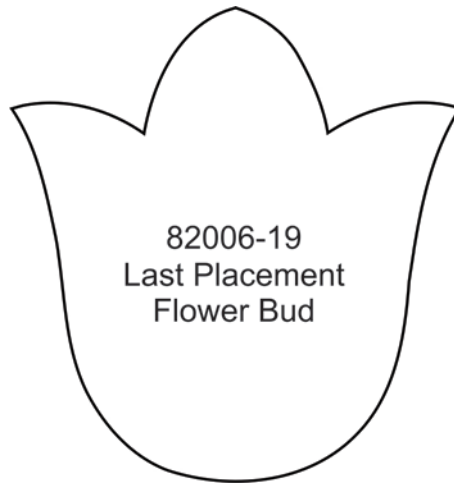

82006-19
Last Placement
Flower Bud

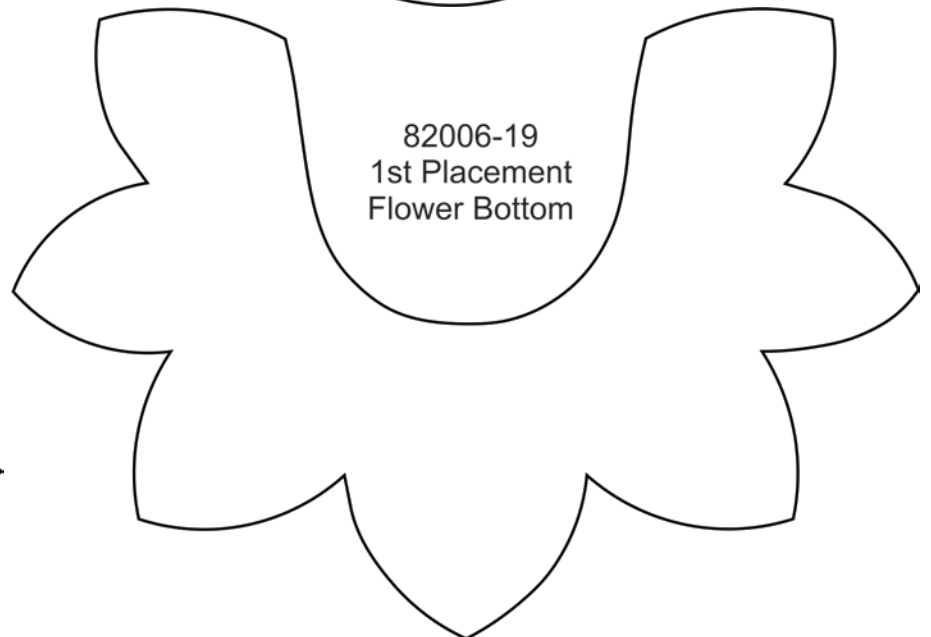

82006-19
1st Placement
Flower Bottom

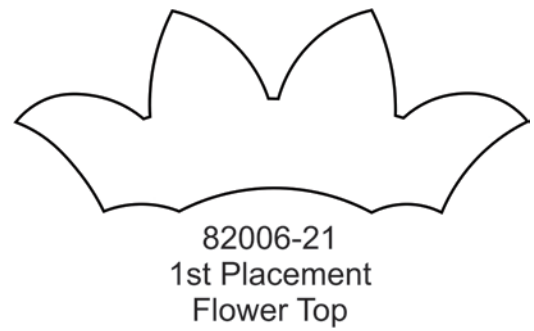
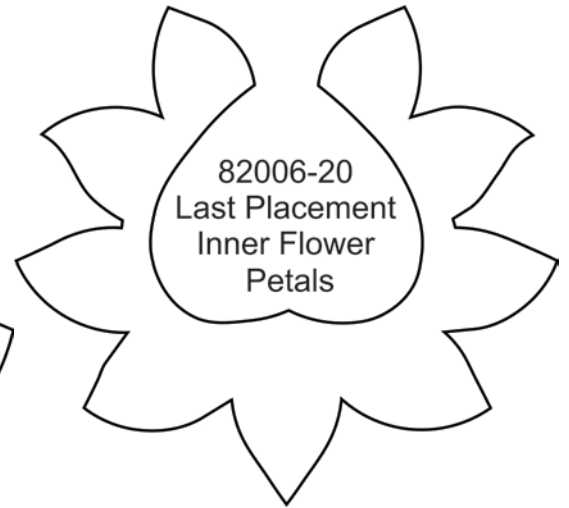
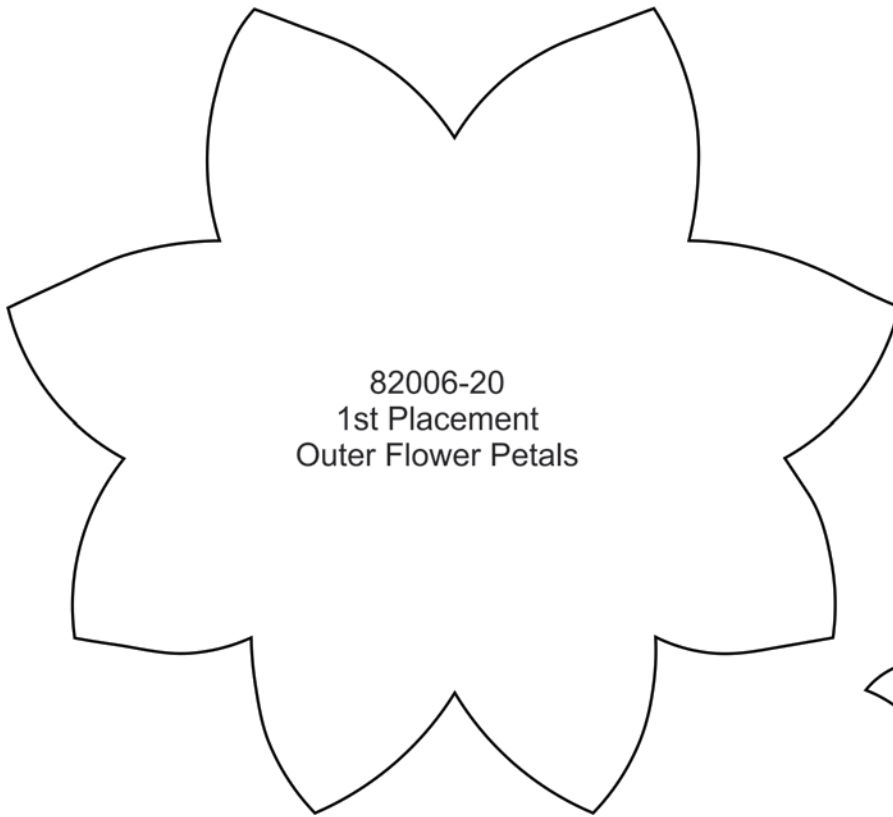

82006-22
Last Placement
Inner Medallion

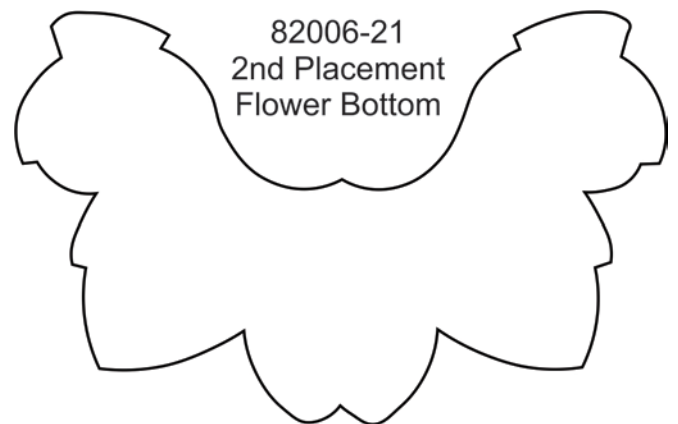
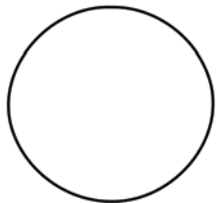

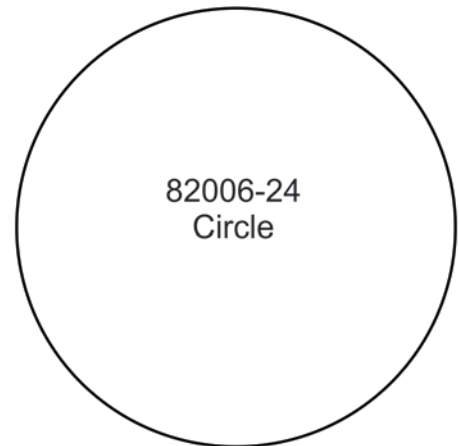
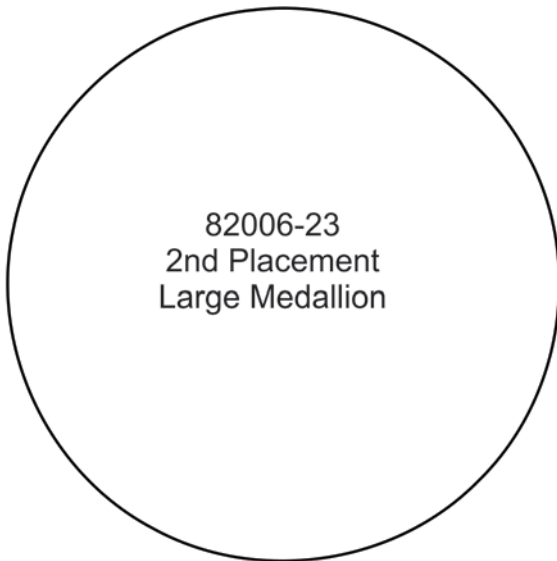
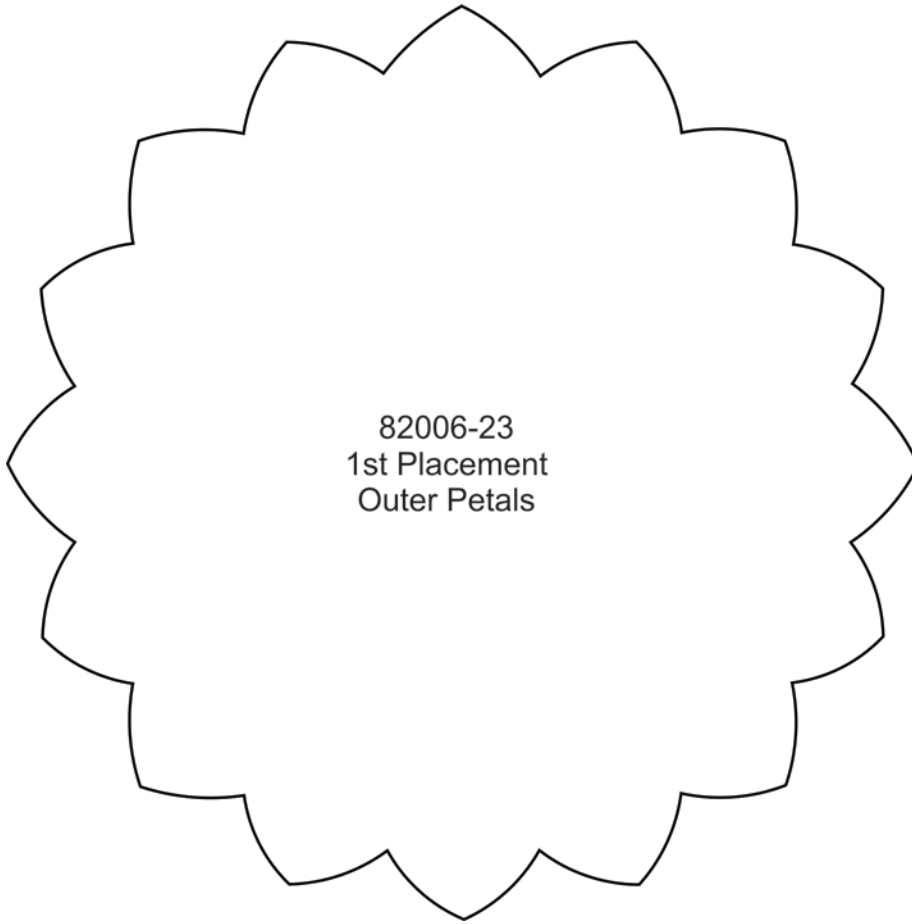

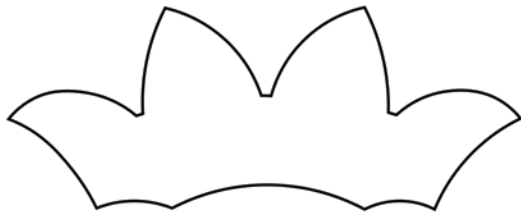

82006-25
1st Placement
Flower Top

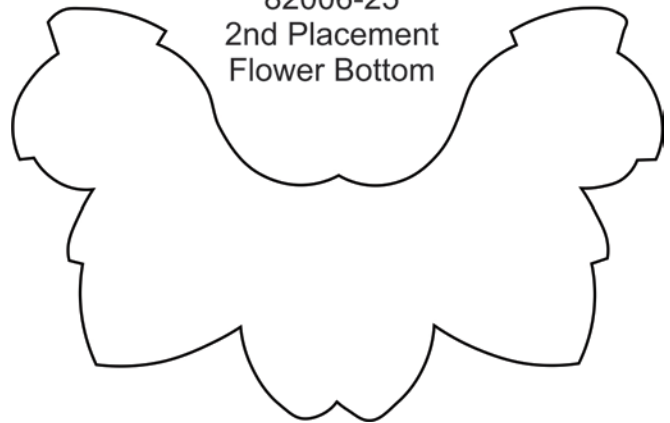

82006-25
2nd Placement
Flower Bottom

82006-25
3rd Placement
Large Medallions

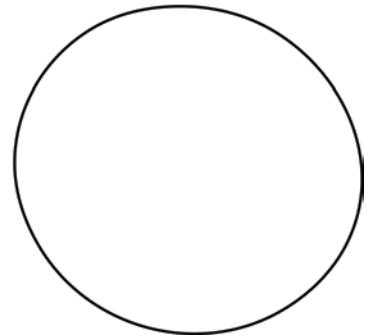
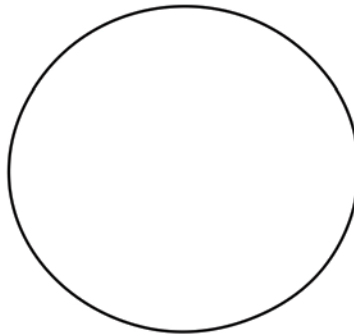
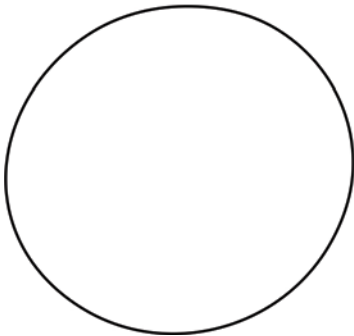

82006-25
4th Placement
Small Medallions

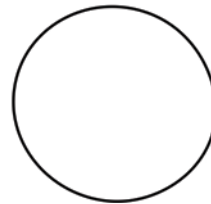
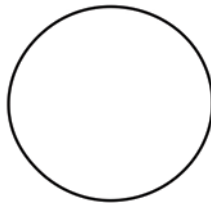
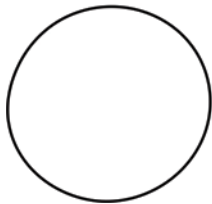

82006-25
Last Placement
Flower Center

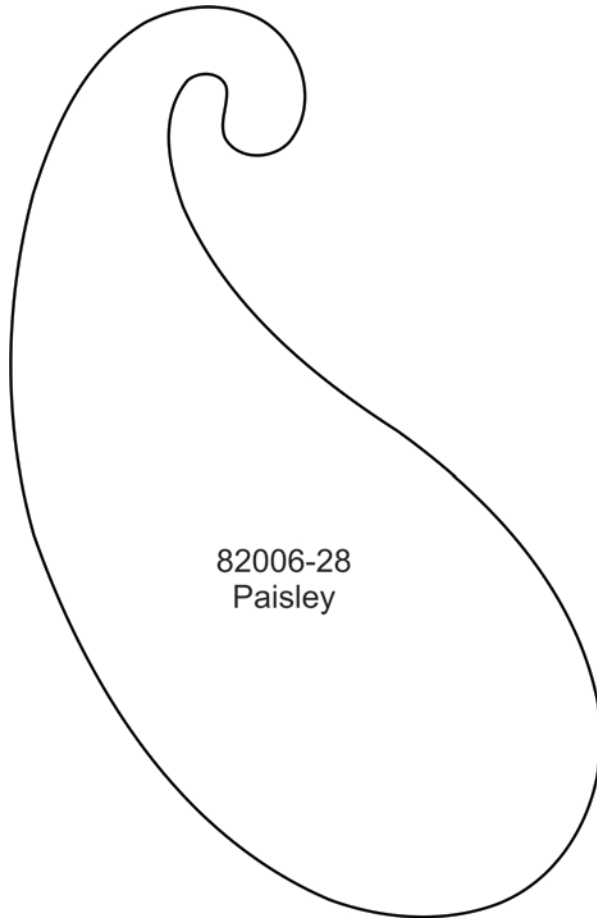

82006-28
Paisley

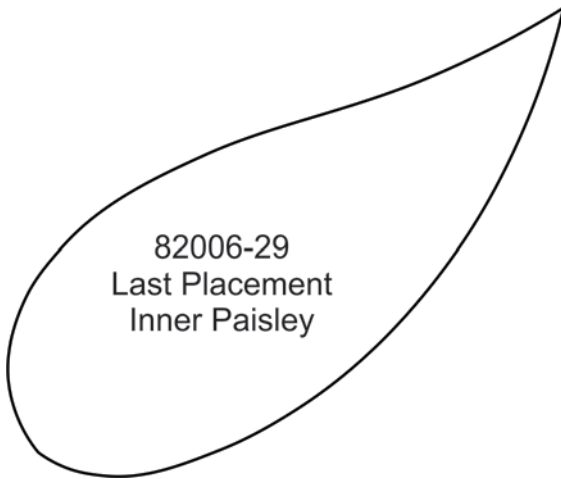

82006-29
Last Placement
Inner Paisley

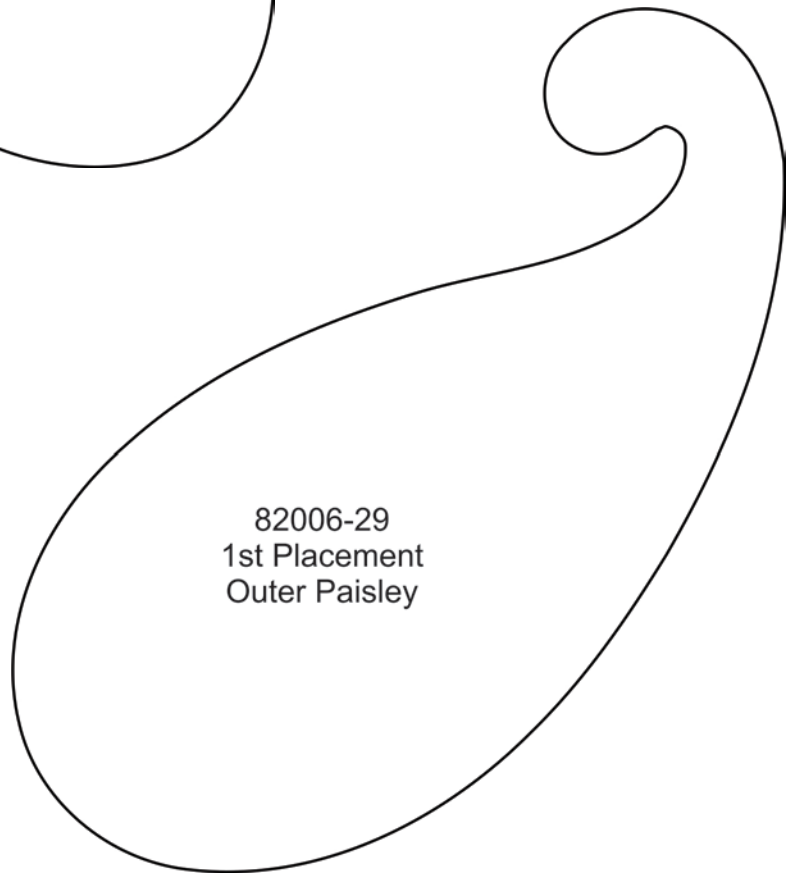

82006-29
1st Placement
Outer Paisley

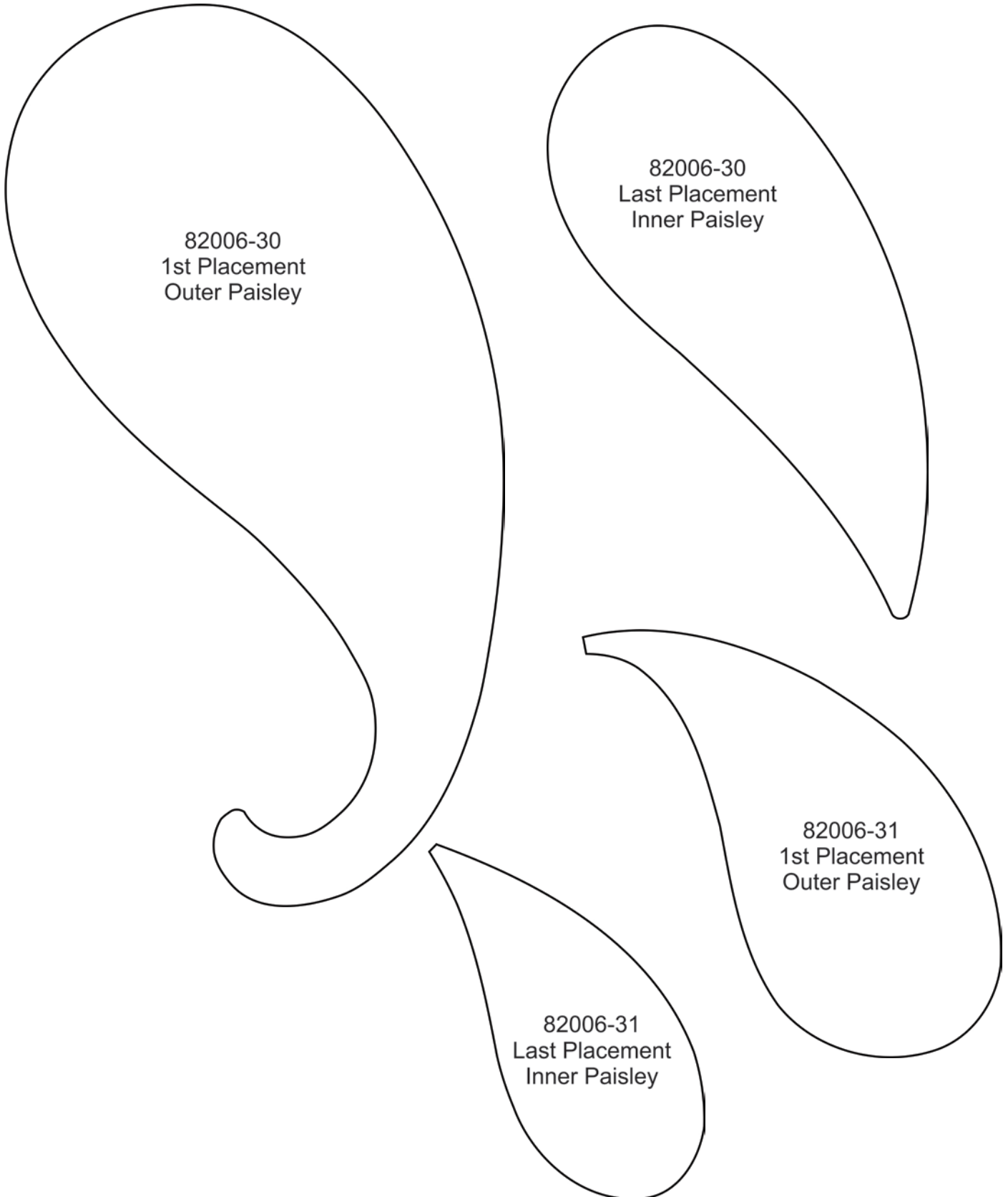

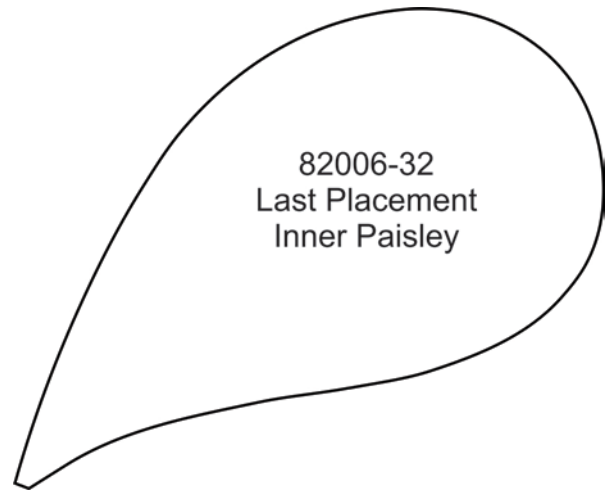
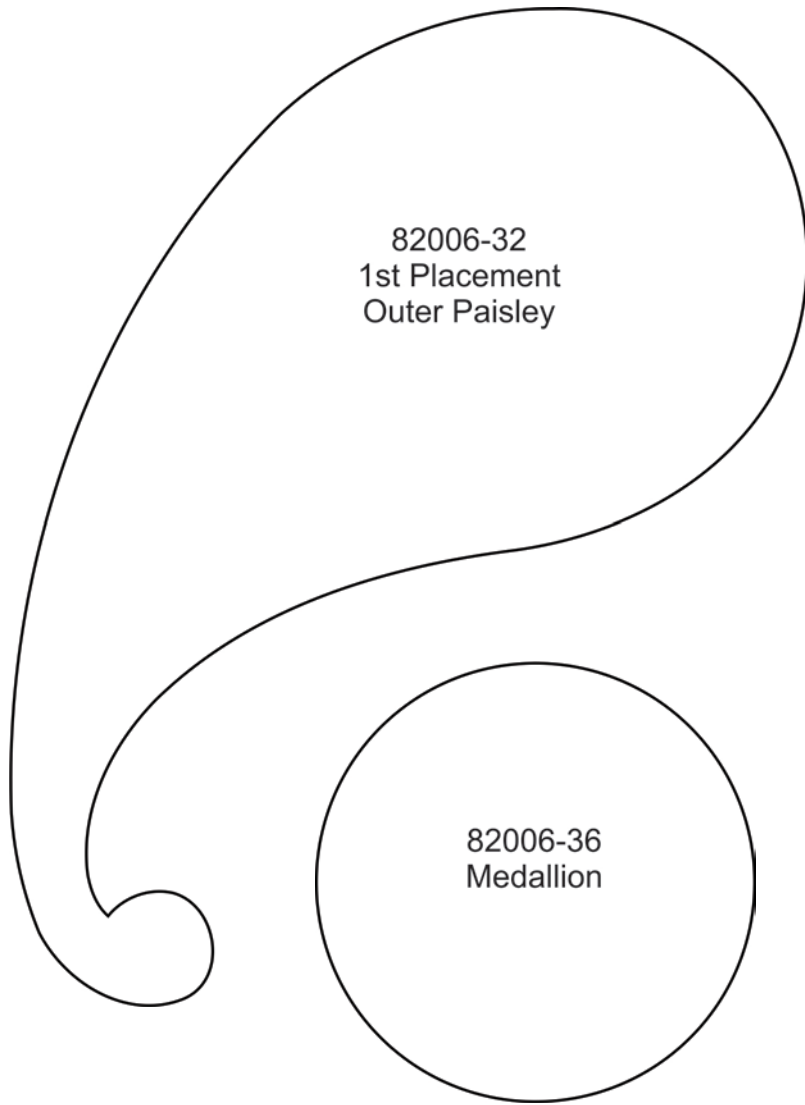

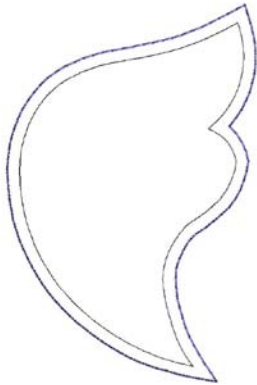

82006-01_CWA_A For Use with the Bernina CutWork Accessory
1.63 X 2.46 in.
41.40 X 62.48 mm
800 St.

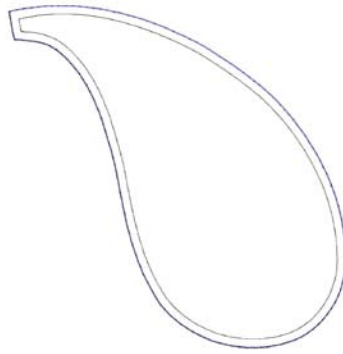

82006-01_CWA_B For Use with the Bernina CutWork Accessory
3.21 X 3.26 in.
81.53 X 82.80 mm
1,200 St.

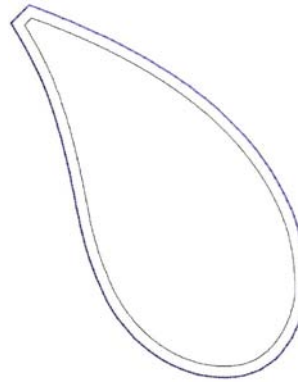

82006-01_CWA_C For Use with the Bernina CutWork Accessory
2.18 X 2.75 in.
55.37 X 69.85 mm
900 St.

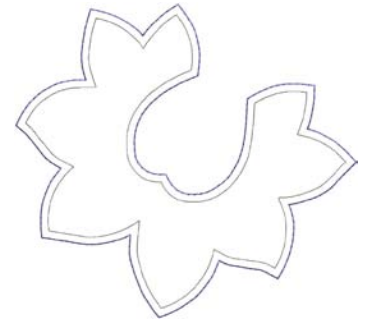

82006-01_CWA_D For Use with the Bernina CutWork Accessory
3.61 X 3.31 in.
91.69 X 84.07 mm
1,900 St.

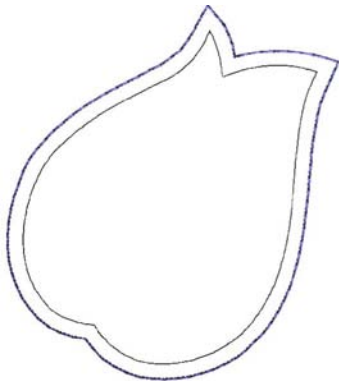

82006-01_CWA_E For Use with the Bernina CutWork Accessory
1.74 X 1.97 in.
44.20 X 50.04 mm
700 St.

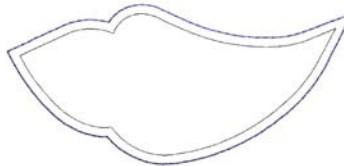

82006-03_CWA_A For Use with the Bernina CutWork Accessory
3.05 X 1.41 in.
77.47 X 35.81 mm
900 St. **S**

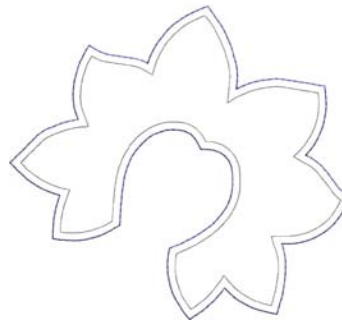

82006-03_CWA_B For Use with the Bernina CutWork Accessory
3.61 X 3.31 in.
91.69 X 84.07 mm
1,900 St.

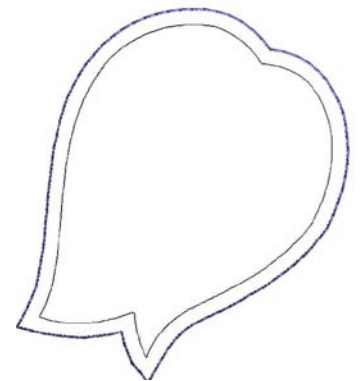

82006-03_CWA_C For Use with the Bernina CutWork Accessory
1.74 X 1.97 in.
44.20 X 50.04 mm
700 St.

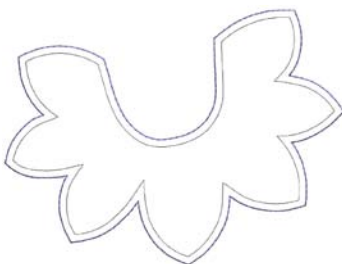

82006-04_CWA_A For Use with the Bernina CutWork Accessory
3.77 X 2.82 in.
95.76 X 71.63 mm
1,800 St.

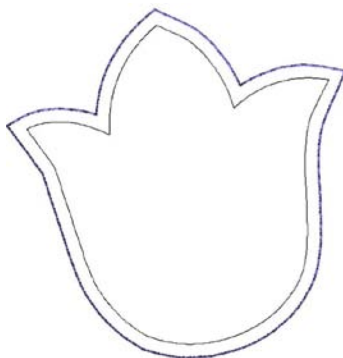

82006-04_CWA_B For Use with the Bernina CutWork Accessory
2.00 X 2.07 in.
50.80 X 52.58 mm
800 St.

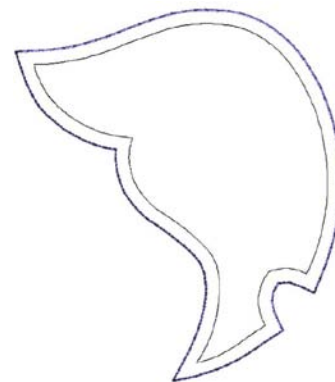

82006-04_CWA_C For Use with the Bernina CutWork Accessory
1.89 X 2.16 in.
48.01 X 54.86 mm
800 St.

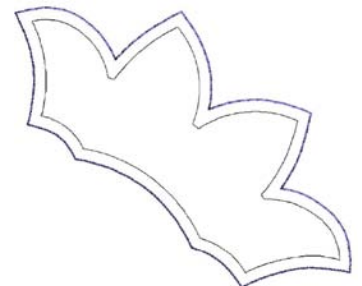

82006-05_CWA_A For Use with the Bernina CutWork Accessory
2.28 X 1.91 in.
57.91 X 48.51 mm
1,000 St.

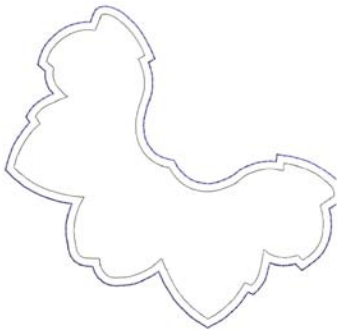

82006-05_CWA_B For Use with the Bernina CutWork Accessory
3.43 X 3.28 in.
87.12 X 83.31 mm
1,500 St.

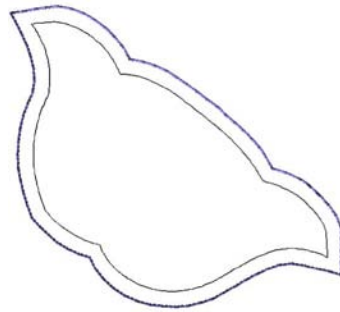

82006-05_CWA_C For Use with the Bernina CutWork Accessory
1.74 X 1.58 in.
44.20 X 40.13 mm
700 St.

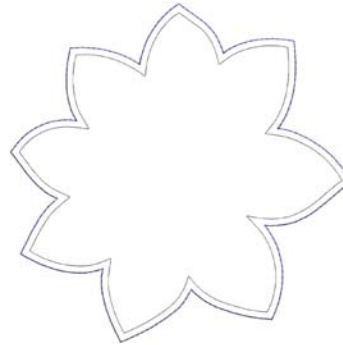

82006-06_CWA_A For Use with the Bernina CutWork Accessory
4.00 X 3.96 in.
101.60 X 100.58 mm
1,900 St.

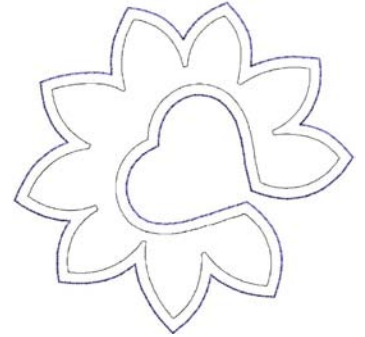

82006-06_CWA_B For Use with the Bernina CutWork Accessory
2.54 X 2.48 in.
64.52 X 62.99 mm
1,700 St.

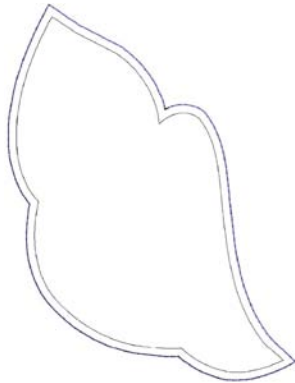

82006-14_CWA For Use with the Bernina CutWork Accessory
2.83 X 3.72 in.
71.88 X 94.49 mm
1,300 St.

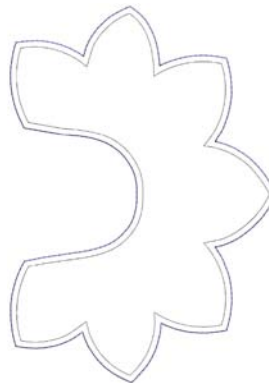

82006-19_CWA_A For Use with the Bernina CutWork Accessory
3.44 X 4.89 in.
87.38 X 124.21 mm
2,200 St.

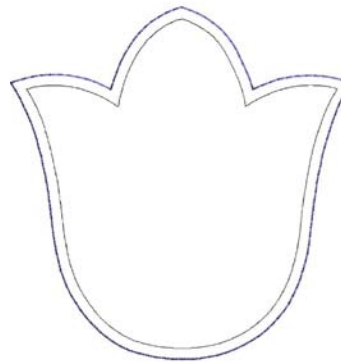

82006-19_CWA_B For Use with the Bernina CutWork Accessory
2.54 X 2.63 in.
64.52 X 66.80 mm
1,100 St.

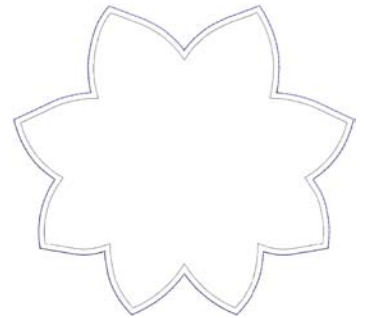

82006-20_CWA_A For Use with the Bernina CutWork Accessory
4.83 X 4.38 in.
122.68 X 111.25 mm
2,200 St.

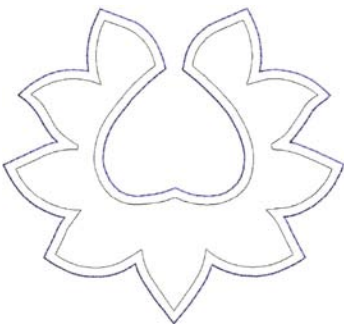

82006-20_CWA_B For Use with the Bernina CutWork Accessory
3.02 X 2.80 in.
76.71 X 71.12 mm
2,000 St.

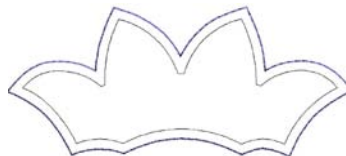

82006-21_CWA_A For Use with the Bernina CutWork Accessory
2.91 X 1.25 in.
73.91 X 31.75 mm
1,000 St. **S**

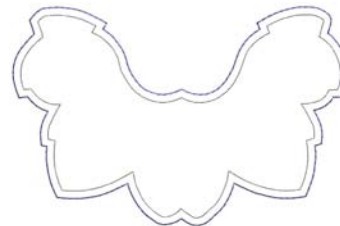

82006-21_CWA_B For Use with the Bernina CutWork Accessory
3.54 X 2.30 in.
89.92 X 58.42 mm
1,500 St.

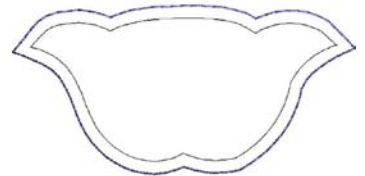

82006-21_CWA_C For Use with the Bernina CutWork Accessory
2.23 X 1.09 in.
56.64 X 27.69 mm
700 St. **S**

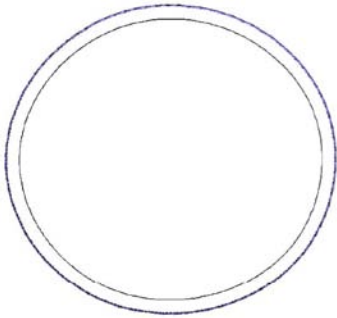

82006-22_CWA_A For Use with the Bernina CutWork Accessory
1.98 X 1.85 in.
50.29 X 46.99 mm
700 St.

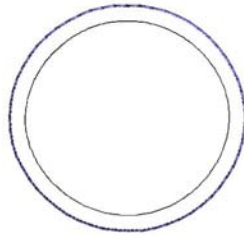

82006-22_CWA_B For Use with the Bernina CutWork Accessory
1.22 X 1.17 in.
30.99 X 29.72 mm
500 St. **S**

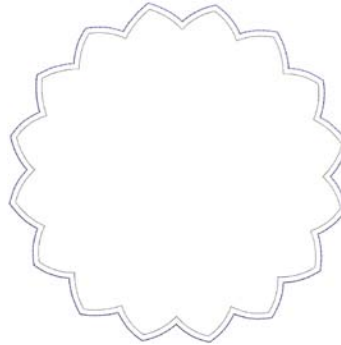

82006-23_CWA_A For Use with the Bernina CutWork Accessory
4.85 X 4.85 in.
123.19 X 123.19 mm
2,200 St.

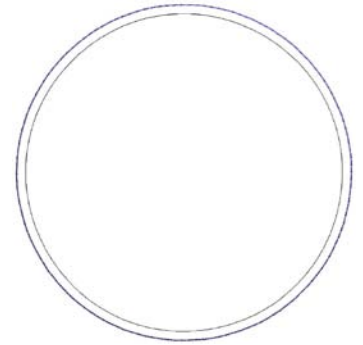

82006-23_CWA_B For Use with the Bernina CutWork Accessory
3.03 X 3.03 in.
76.96 X 76.96 mm
1,100 St.

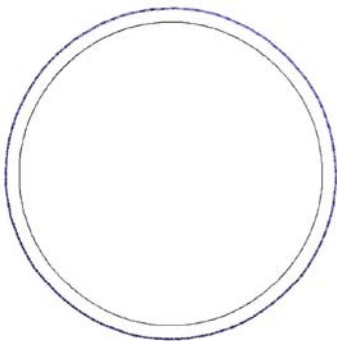

82006-23_CWA_C For Use with the Bernina CutWork Accessory
1.99 X 2.00 in.
50.55 X 50.80 mm
800 St.

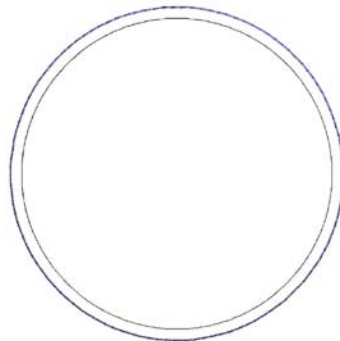

82006-24_CWA For Use with the Bernina CutWork Accessory
2.44 X 2.44 in.
61.98 X 61.98 mm
900 St.



82006-25_CWA_A For Use with the Bernina CutWork Accessory
2.91 X 1.25 in.
73.91 X 31.75 mm
1,000 St. **S**

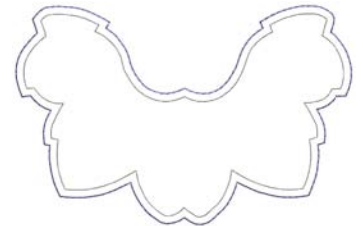

82006-25_CWA_B For Use with the Bernina CutWork Accessory
3.54 X 2.30 in.
89.92 X 58.42 mm
1,500 St.



82006-25_CWA_C For Use with the Bernina CutWork Accessory
1.86 X 6.47 in.
47.24 X 164.34 mm
2,400 St. **L**

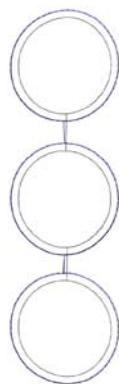

82006-25_CWA_D For Use with the Bernina CutWork Accessory
1.17 X 4.09 in.
29.72 X 103.89 mm
1,500 St. **S**

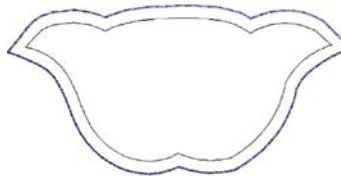

82006-25_CWA_E For Use with the Bernina CutWork Accessory
2.23 X 1.09 in.
56.64 X 27.69 mm
700 St. **S**

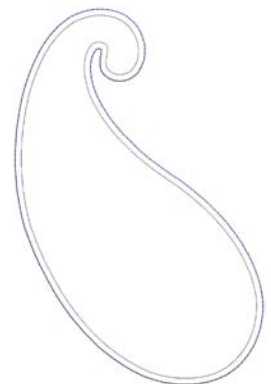

82006-28_CWA For Use with the Bernina CutWork Accessory
3.23 X 4.89 in.
82.04 X 124.21 mm
1,700 St.

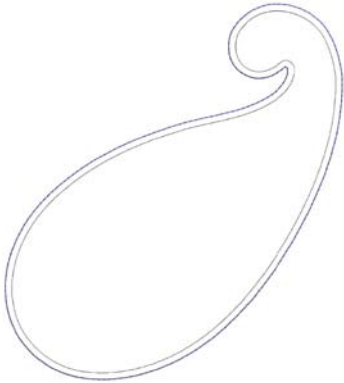

82006-29_CWA_A For Use with the Bernina CutWork Accessory
4.17 X 4.65 in.
105.92 X 118.11 mm
1,800 St.

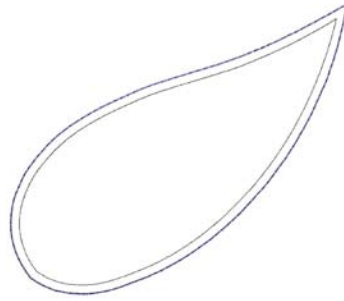

82006-29_CWA_B For Use with the Bernina CutWork Accessory
3.07 X 2.64 in.
77.98 X 67.06 mm
1,100 St.



82006-30_CWA_A For Use with the Bernina CutWork Accessory
3.78 X 6.72 in.
96.01 X 170.69 mm
2,200 St. **L**

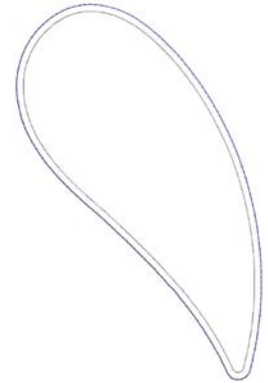

82006-30_CWA_B For Use with the Bernina CutWork Accessory
2.92 X 4.48 in.
74.17 X 113.79 mm
1,400 St.

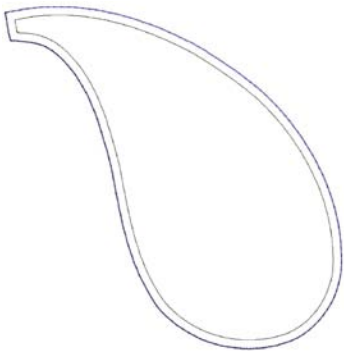

82006-31_CWA_A For Use with the Bernina CutWork Accessory
3.21 X 3.26 in.
81.53 X 82.80 mm
1,200 St.

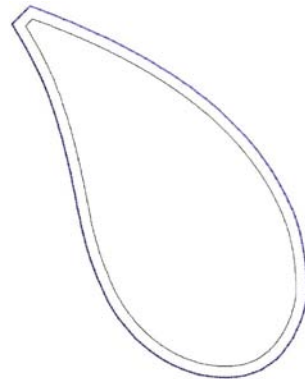

82006-31_CWA_B For Use with the Bernina CutWork Accessory
2.18 X 2.75 in.
55.37 X 69.85 mm
900 St.



82006-32_CWA_A For Use with the Bernina CutWork Accessory
4.30 X 5.35 in.
109.22 X 135.89 mm
2,000 St. **L**

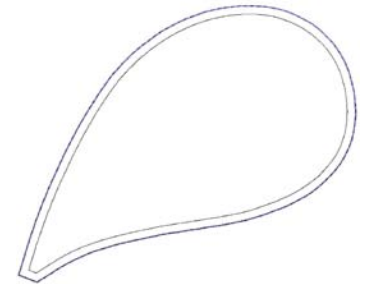

82006-32_CWA_B For Use with the Bernina CutWork Accessory
3.24 X 2.65 in.
82.30 X 67.31 mm
1,100 St.

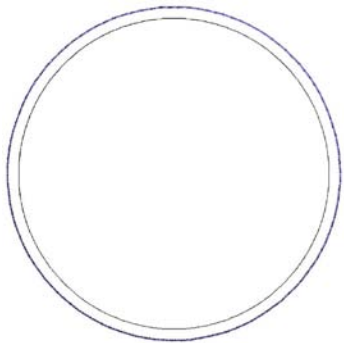

82006-36_CWA For Use with the Bernina CutWork Accessory
2.44 X 2.44 in.
61.98 X 61.98 mm
900 St.

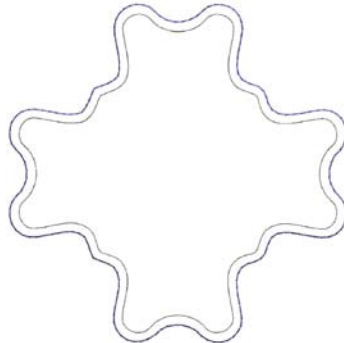

82006-40_CWA For Use with the Bernina CutWork Accessory
3.15 X 3.15 in.
80.01 X 80.01 mm
1,400 St.

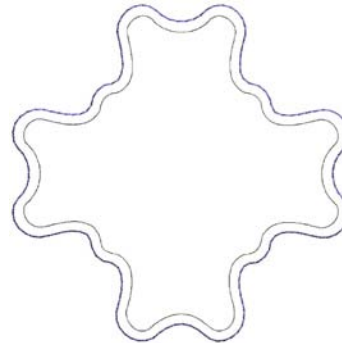

82006-41_CWA For Use with the Bernina CutWork Accessory
2.80 X 2.80 in.
71.12 X 71.12 mm
1,200 St.

SUPPLIES

- Cut-Away Stabilizer
- Temporary Spray Adhesive
- Appliqué Fuse & Fix Stabilizer
- Embroidery Thread
- Stabilizer that is appropriate for your project
- BERNINA® CutWork Accessory

PREPARE APPLIQUE FABRIC

1. Starch appliqué fabric 2-3 times following manufacturer's instructions.
2. Appliqué fabric should be crisp.
3. Iron Appliqué Fuse & Fix to the wrong side of the starched appliqué fabric following instructions on product packaging.

CUT APPLIQUE PIECES

1. Hoop one layer of Cut-Away Stabilizer.
2. Send first CWA file to the embroidery machine. (CWA files are the pre-cut appliqué files to use with the CutWork Accessory; these files will end in CWA01, CWA02, and CWA03 etc. The number of CWA files available for each design will depend upon how many separate appliqué designs each design contains.)
3. Stitch the first color, this will be the placement stitch.
4. Remove the hoop from the machine but do not remove the stabilizer from the hoop. Spray the hooped stabilizer with temporary spray adhesive. Lay prepared appliqué fabric over the placement stitch, being sure to completely cover the stitching. Apply pressure to appliqué fabric to ensure it is adhered.
5. Stitch the second color, this will be the basting stitch. It is meant to baste the appliqué fabric to your hooped stabilizer.
6. Replace normal stitch plate with the CutWork stitch plate.
7. Unthread the machine.
8. If necessary, turn off the upper thread control on your machine. Refer to your machine's user manual. Note that the most recent version of the 830 will perform this task automatically.
9. Replace embroidery needle with the CutWork Accessory.
10. Replace embroidery foot with foot #44 (If you do not have foot #44 you can leave foot #15 on the machine; foot #44 will simply keep the cut fabric from flagging as much).
11. Attach the hoop to the machine.
12. To cut the first appliqué piece follow the "thread changes" on your machine screen and turn the dial on the CutWork tool as required.
13. Remove the hoop from the machine.
14. Gently remove cut appliqué piece, trimming any thread that may have not been cut completely. **PHOTO 1**
15. Repeat as needed for designs with multiple appliqué pieces.

TACKDOWN APPLIQUE AND COMPLETE EMBROIDERY DESIGN

1. Replace the embroidery needle and rethread the machine.
2. Replace the embroidery foot #15.
3. Spray hoop sized piece of stabilizer that is appropriate for your project and adhere to wrong side of background fabric or project that is to be hooped.
4. Hoop fabric/project and stabilizer.
5. Attach hoop to machine.
6. Send the embroidery file to the machine (this is not a CWA file).
7. Stitch design as normal following the thread changes on the provided thread chart stopping after each Appliqué Placement Stitch.
8. After stitching an Appliqué Placement Stitch, take the precut appliqué pieces required and peel off the cutaway backing and the release paper revealing a sticky backing. **PHOTO 2**
9. Remove hoop from machine, but do not remove the fabric from the hoop.
10. Adhere precut appliqué piece evenly over the Appliqué Placement Stitch; use pressure to make sure pieces stick well. **PHOTO 3**
11. Reattach hoop to machine.
12. Continue stitching design until all appliqué pieces are placed and all stitching is complete. **PHOTO 4**

NOTE: Design pictured is for instructional purposes and is not included in this collection.

