

DRESDEN DAISIES

- Collection No. 82028
- 35 Designs
- Project instructions included



35
Designs

THREAD LIST



Isacord Thread Colors

0020 Black
0811 Candlelight
0824 Liberty Gold
0922 Ashley Gold
1352 Salmon
1521 Flamingo
1725 Terra Cotta
3611 Blue Ribbon
3722 Empire Blue
3820 Celestial
5100 Green
5210 Trellis Green
5230 Bottle Green

Note: Some designs in this collection may have been created using unique special stitches and/or techniques. To preserve design integrity when rescaling or rotating designs in your software, always rescale or rotate designs using the handles directly on-screen.

***Fabric Required**



82028-01 Large Dresden Applique Daisy

Size Inches: Size mm: Stitch Count:
8.86 X 8.86 in. 225.0 X 225.0 mm 35293 St.

1. Yellow Fabric Placement Stitch	3820
2. Cut Line and Tackdown	3820
3. Dark Green Fabric Placement Stitch	3820
4. Cut Line and Tackdown	3820
5. Dark Blue Fabric Placement Stitch	3820
6. Cut Line and Tackdown	3820
7. Tan Fabric Placement Stitch	3820
8. Cut Line and Tackdown	3820
9. Red Fabric Placement Stitch	3820
10. Cut Line and Tackdown	3820
11. Light Blue Fabric Placement Stitch	3820
12. Cut Line and Tackdown	3820
13. Brown Fabric Placement Stitch	3820
14. Cut Line and Tackdown	3820
15. Light Green Fabric Placement Stitch	3820
16. Cut Line and Tackdown	3820
17. Light Blue Detail	3820
18. Dark Green Detail	5100
19. Medium Red Detail	1521
20. Medium Blue Detail	3722
21. Light Green Detail	5230
22. Medium Gold Detail	0824
23. Light Gold Detail	0811
24. Medium Green Detail	5210
25. Light Red Detail	1352
26. Dark Red Detail	1725
27. Dark Blue Detail	3611
28. Dark Gold Detail	0922
29. Light Blue Cover Stitch	3820

Note: Some designs in this collection may have been created using unique special stitches and/or techniques. To preserve design integrity when rescaling or rotating designs in your software, always rescale or rotate designs using the handles directly on-screen.

***Fabric Required**



82028-02 Large Dresden Applique Daisies

Size Inches: Size mm: Stitch Count:
8.80 X 8.77 in. 223.5 X 222.8 mm 28087 St.

■ 1. Light Yellow Fabric Placement Stitch	5230
■ 2. Cut Line and Tackdown	5230
■ 3. Red Fabric Placement Stitch	5230
■ 4. Cut Line and Tackdown	5230
■ 5. Dark Blue Fabric Placement Stitch	5230
■ 6. Cut Line and Tackdown	5230
■ 7. Light Green Detail	5230
■ 8. Medium Blue Detail	3722
■ 9. Light Blue Detail	3820
■ 10. Dark Blue Detail	3611
■ 11. Light Gold Cover Stitch and Detail	0811
■ 12. Medium Green Detail	5210
■ 13. Medium Red Detail	1521
■ 14. Medium Gold Detail	0824
■ 15. Light Red Cover Stitch and Detail	1352
■ 16. Dark Gold Detail	0922
■ 17. Light Blue Cover Stitch	3820

Note: Some designs in this collection may have been created using unique special stitches and/or techniques. To preserve design integrity when rescaling or rotating designs in your software, always rescale or rotate designs using the handles directly on-screen.

***Fabric Required**



82028-03 Dresden Daisies Applique Circle

Size Inches: Size mm: Stitch Count:
6.86 X 6.86 in. 174.2 X 174.2 mm 17211 St.

- 1. Light Yellow Fabric Placement Stitch0811
- 2. Cut Line and Tackdown0811
- 3. Light Gold Cover Stitch0811
- 4. Light Gold Detail.....0811
- 5. Medium Gold Detail..... 0824
- 6. Dark Gold Detail 0922
- 7. Light Red Detail..... 1352
- 8. Medium Red Detail..... 1521
- 9. Dark Red Detail 1725
- 10. Light Blue Detail 3820
- 11. Medium Blue Detail 3722
- 12. Dark Blue Detail3611

***Fabric Required**



82028-04 Dresden Daisies Applique Vase

Size Inches: Size mm: Stitch Count:
8.66 X 4.99 in. 220.0 X 126.7 mm 16758 St.

- 1. Light Yellow Fabric Placement Stitch 0922
- 2. Cut Line and Tackdown 0922
- 3. Dark Red Fabric Placement Stitch 0922
- 4. Cut Line and Tackdown 0922
- 5. Light Blue Fabric Placement Stitch 0922
- 6. Cut Line and Tackdown 0922
- 7. Dark Gold Detail 0922
- 8. Dark Red Detail 1725
- 9. Light Gold Cover Stitch and Detail0811
- 10. Medium Gold Detail..... 0824
- 11. Light Red Detail..... 1352
- 12. Dark Red Cover Stitch and Detail 1725
- 13. Light Blue Cover Stitch..... 3820
- 14. Medium Blue Detail 3722
- 15. Dark Blue Detail3611

Note: Some designs in this collection may have been created using unique special stitches and/or techniques. To preserve design integrity when rescaling or rotating designs in your software, always rescale or rotate designs using the handles directly on-screen.

***Fabric Required**

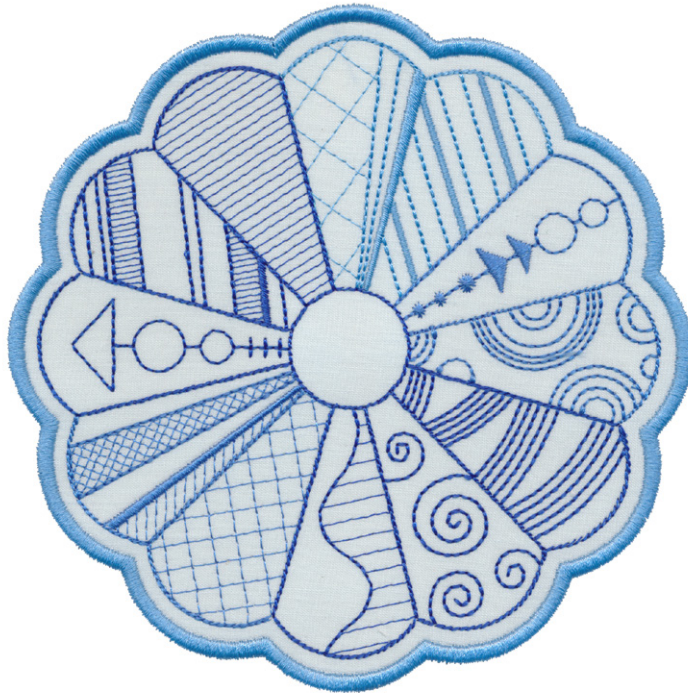

82028-05 Dresden Daisy Applique 1

Size Inches:	Size mm:	Stitch Count:
5.63 X 5.62 in.	143.0 X 142.7 mm	12380 St.

- 1. Light Blue Fabric Placement Stitch 3820
- 2. Cut Line and Tackdown 3820
- 3. Light Blue Cover Stitch 3820
- 4. Light Blue Detail 3820
- 5. Medium Blue Detail 3722
- 6. Dark Blue Detail 3611

***Fabric Required**



82028-06 Dresden Daisy Applique 2

Size Inches:	Size mm:	Stitch Count:
5.19 X 5.18 in.	131.8 X 131.6 mm	10686 St.

- 1. Dark Green Fabric Placement Stitch 5210
- 2. Cut Line and Tackdown 5210
- 3. Medium Green Detail 5210
- 4. Light Green Detail 5230

Note: Some designs in this collection may have been created using unique special stitches and/or techniques. To preserve design integrity when rescaling or rotating designs in your software, always rescale or rotate designs using the handles directly on-screen.

***Fabric Required**

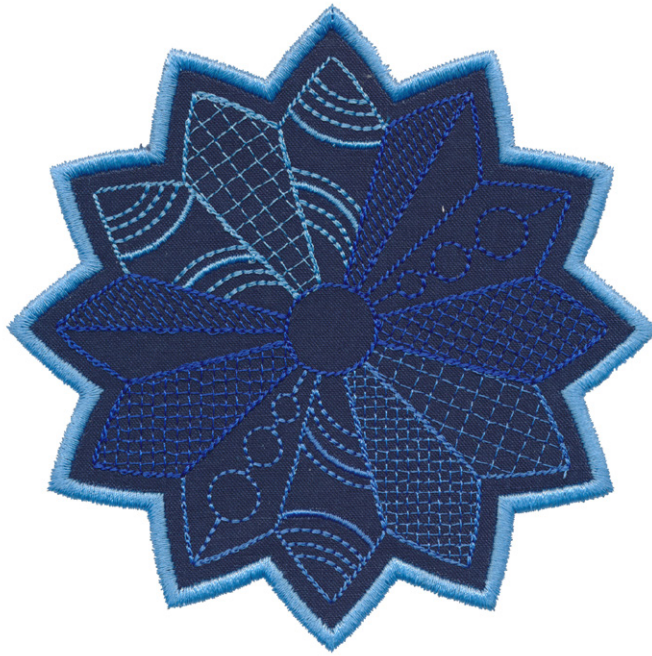

82028-07 Dresden Daisy Applique 3

Size Inches: Size mm: Stitch Count:
 4.85 X 4.85 in. 123.2 X 123.2 mm 9294 St.

- 1. Dark Blue Fabric Placement Stitch..... 3820
- 2. Cut Line and Tackdown 3820
- 3. Light Blue Cover Stitch..... 3820
- 4. Light Blue Detail 3820
- 5. Medium Blue Detail 3722
- 6. Dark Blue Detail 3611

***Fabric Required**

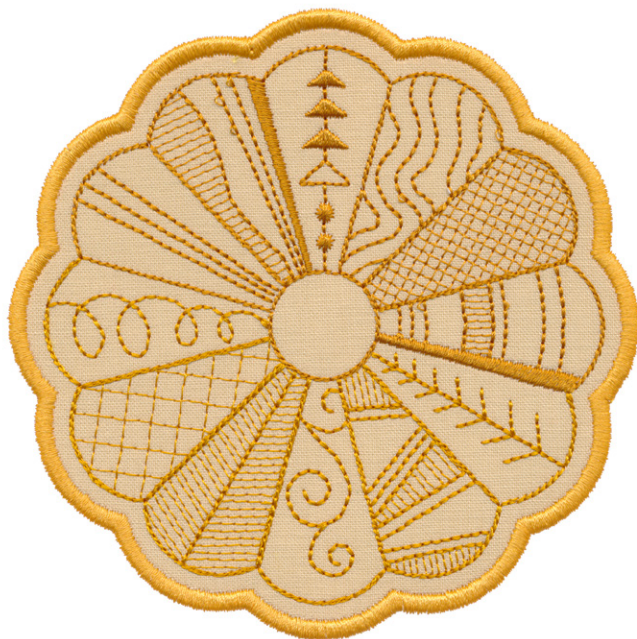

82028-08 Dresden Daisy Applique 4

Size Inches: Size mm: Stitch Count:
 4.69 X 4.69 in. 119.1 X 119.1 mm 9223 St.

- 1. Light Yellow Fabric Placement Stitch 0811
- 2. Cut Line and Tackdown 0811
- 3. Light Gold Cover Stitch 0811
- 4. Medium Gold Detail..... 0824
- 5. Dark Gold Detail 0922

Note: Some designs in this collection may have been created using unique special stitches and/or techniques. To preserve design integrity when rescaling or rotating designs in your software, always rescale or rotate designs using the handles directly on-screen.

***Fabric Required**

82028-09 Dresden Daisy Applique 5

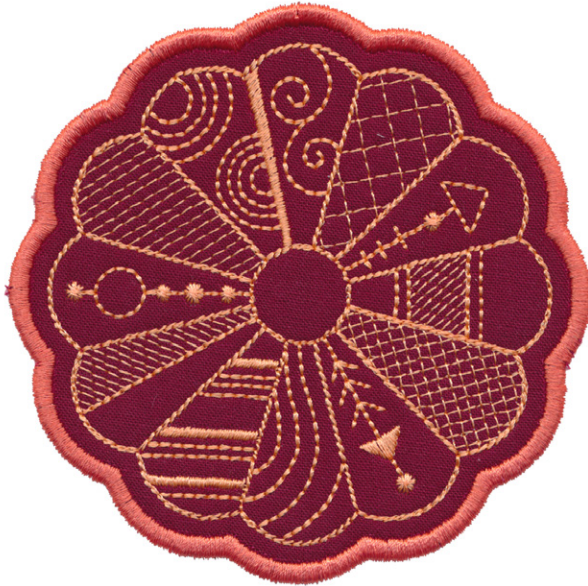





Size Inches:	Size mm:	Stitch Count:
3.84 X 3.84 in.	97.5 X 97.5 mm	6823 St.
 1. Dark Red Fabric Placement Stitch	1521	
 2. Cut Line and Tackdown	1521	
 3. Medium Red Cover Stitch	1521	
 4. Light Red Detail	1352	

***Fabric Required**

82028-10 Dresden Daisy Applique 6



Size Inches:	Size mm:	Stitch Count:
3.67 X 3.67 in.	93.2 X 93.2 mm	6024 St.
 1. Brown Fabric Placement Stitch	0824	
 2. Cut Line and Tackdown	0824	
 3. Medium Gold Cover Stitch	0824	
 4. Light Gold Detail	0811	

Note: Some designs in this collection may have been created using unique special stitches and/or techniques. To preserve design integrity when rescaling or rotating designs in your software, always rescale or rotate designs using the handles directly on-screen.

***Fabric Required**

82028-11 Dresden Butterfly Applique

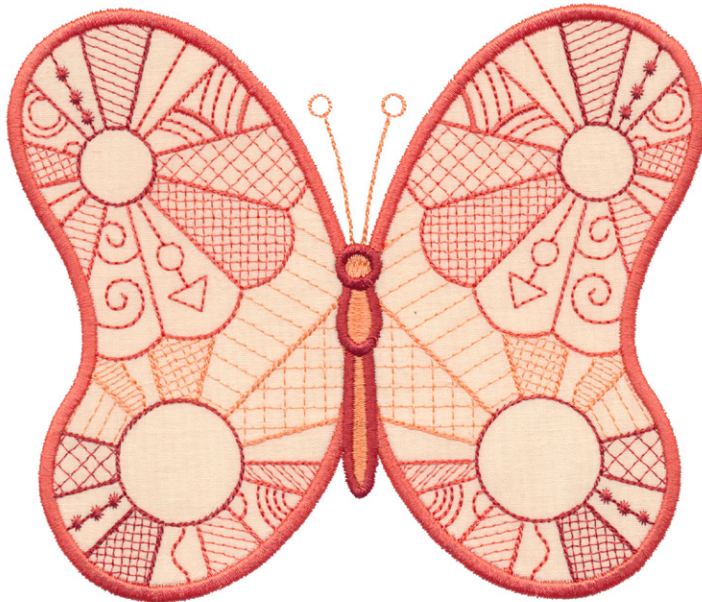

Size Inches:	Size mm:	Stitch Count:
5.27 X 6.19 in.	133.9 X 157.2 mm	16493 St.
 1. Tan Fabric Placement Stitch.....		1352
 2. Cut Line and Tackdown		1352
 3. Light Red Detail.....		1352
 4. Medium Red Detail.....		1521
 5. Dark Red Detail		1725
 6. Medium Red Cover Stitch		1521
 7. Dark Red Body		1725

***Fabric Required**

82028-12 Dresden Daisies Applique Group

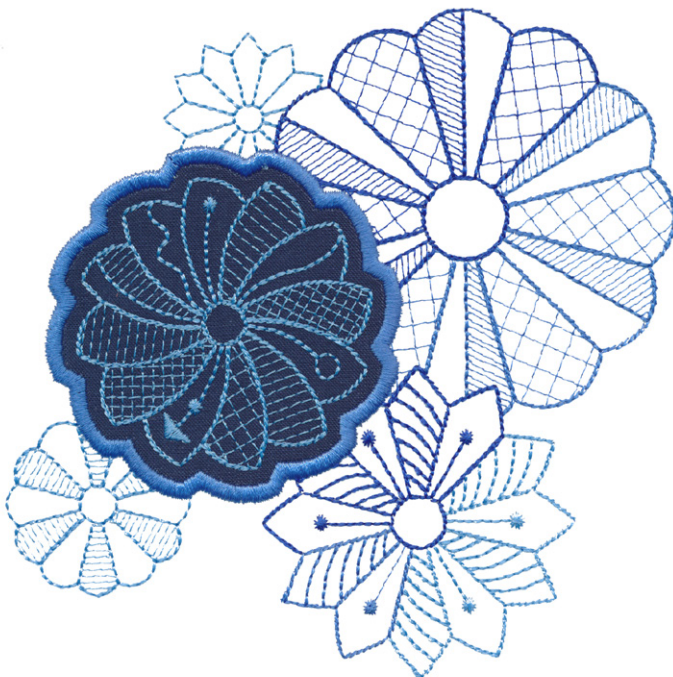

Size Inches:	Size mm:	Stitch Count:
5.21 X 5.22 in.	132.3 X 132.6 mm	10380 St.
 1. Dark Blue Fabric Placement Stitch.....		3820
 2. Cut Line and Tackdown		3820
 3. Light Blue Detail		3820
 4. Medium Blue Detail		3722
 5. Dark Blue Detail		3611
 6. Medium Blue Cover Stitch.....		3722

Note: Some designs in this collection may have been created using unique special stitches and/or techniques. To preserve design integrity when rescaling or rotating designs in your software, always rescale or rotate designs using the handles directly on-screen.

***Fabric Required**

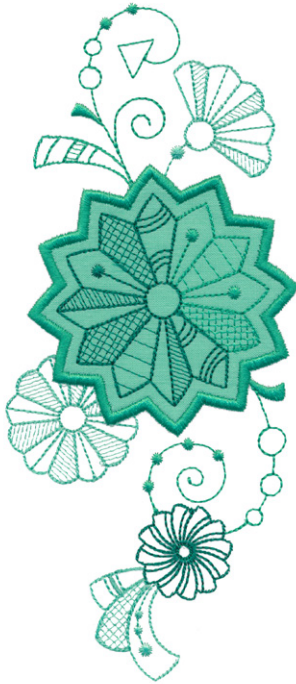

82028-13 Dresden Daisies Vine Applique 1

Size Inches:	Size mm:	Stitch Count:
8.37 X 3.60 in.	212.6 X 91.4 mm	10346 St.

- 1. Light Green Fabric Placement Stitch..... 5230
- 2. Cut Line and Tackdown 5230
- 3. Light Green Detail 5230
- 4. Medium Green Detail 5210
- 5. Dark Green Detail..... 5100
- 6. Medium Green Cover Stitch 5210

***Fabric Required**

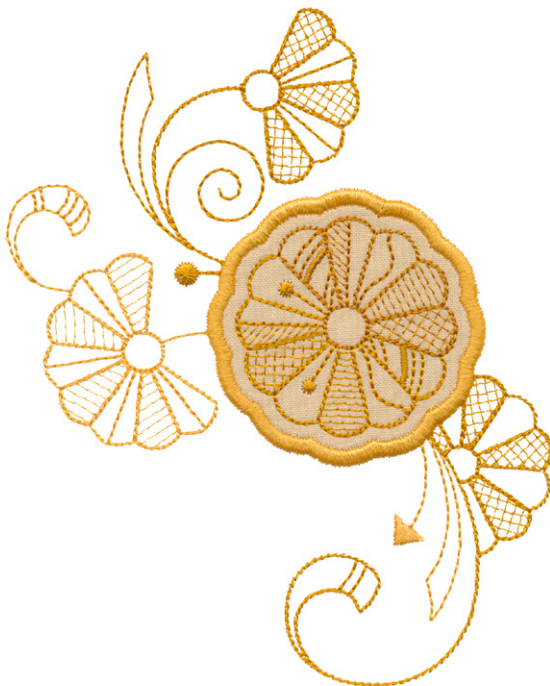

82028-14 Dresden Daisies Vine Applique 2

Size Inches:	Size mm:	Stitch Count:
5.70 X 4.63 in.	144.8 X 117.6 mm	7164 St.



- 1. Light Yellow Fabric Placement Stitch 0824
- 2. Cut Line and Tackdown 0824
- 3. Medium Gold Detail..... 0824
- 4. Dark Gold Detail..... 0922
- 5. Light Gold Detail.....0811
- 6. Light Gold Cover Stitch0811

Note: Some designs in this collection may have been created using unique special stitches and/or techniques. To preserve design integrity when rescaling or rotating designs in your software, always rescale or rotate designs using the handles directly on-screen.

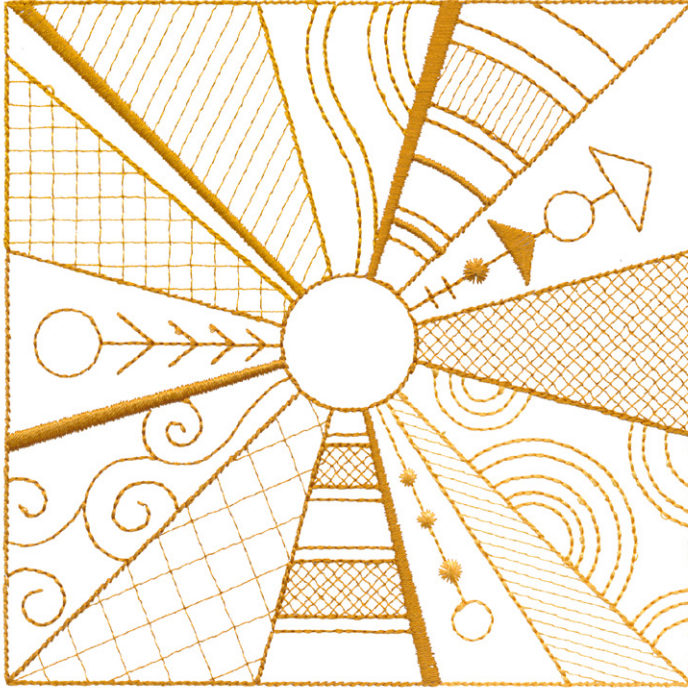
82028-15 Dresden Square 1



Size Inches: 5.27 X 5.27 in. Size mm: 133.9 X 133.9 mm Stitch Count: 9487 St.

	1. Medium Gold Detail.....	0824
	2. Light Gold Detail.....	0811
	3. Dark Gold Detail.....	0922

82028-16 Dresden Square 2



Size Inches: 5.29 X 5.29 in. Size mm: 134.4 X 134.4 mm Stitch Count: 10972 St.

	1. Light Blue Detail.....	3820
	2. Medium Blue Detail.....	3722
	3. Dark Blue Detail.....	3611

Note: Some designs in this collection may have been created using unique special stitches and/or techniques. To preserve design integrity when rescaling or rotating designs in your software, always rescale or rotate designs using the handles directly on-screen.

82028-17 Dresden Square 3

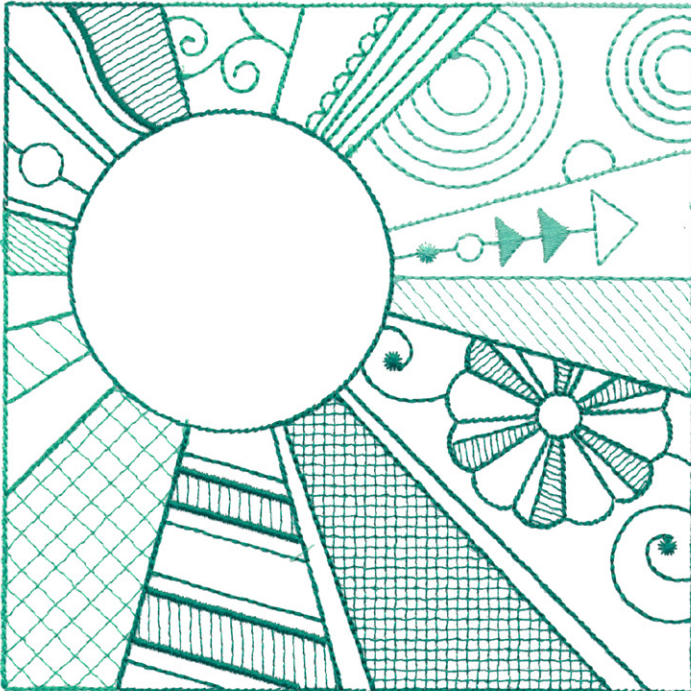

Size Inches: Size mm: Stitch Count:
 5.29 X 5.29 in. 134.4 X 134.4 mm 9280 St.

- 1. Light Green Detail 5230
- 2. Medium Green Detail 5210
- 3. Dark Green Detail..... 5100

82028-18 Dresden Square 4



Size Inches: Size mm: Stitch Count:
 5.29 X 5.29 in. 134.4 X 134.4 mm 10559 St.

- 1. Light Red Detail..... 1352
- 2. Medium Red Detail..... 1521
- 3. Dark Red Detail..... 1725

Note: Some designs in this collection may have been created using unique special stitches and/or techniques. To preserve design integrity when rescaling or rotating designs in your software, always rescale or rotate designs using the handles directly on-screen.

82028-19 Dresden Daisies Vine 1



Size Inches: Size mm: Stitch Count:
 7.94 X 4.81 in. 201.7 X 122.2 mm 8754 St.

- 1. Light Blue Detail 3820
- 2. Medium Blue Detail 3722
- 3. Dark Blue Detail 3611

82028-20 Dresden Daisies Vine 2



Size Inches: Size mm: Stitch Count:
 6.69 X 4.89 in. 169.9 X 124.2 mm 6144 St.

- 1. Medium Red Detail 1521
- 2. Light Red Detail 1352
- 3. Dark Red Detail 1725

Note: Some designs in this collection may have been created using unique special stitches and/or techniques. To preserve design integrity when rescaling or rotating designs in your software, always rescale or rotate designs using the handles directly on-screen.

82028-21 Dresden Daisies Vine 3

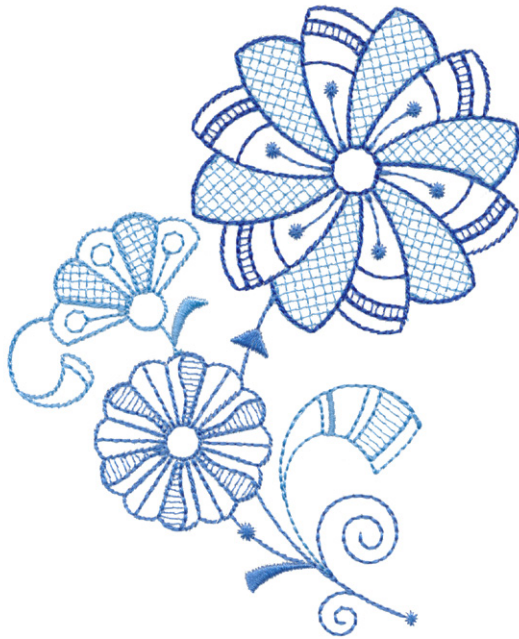

Size Inches: Size mm: Stitch Count:
 5.41 X 4.31 in. 137.4 X 109.5 mm 7168 St.

- 1. Light Blue Detail 3820
- 2. Dark Blue Detail 3611
- 3. Medium Blue Detail 3722

82028-22 Dresden Daisies Vine 4



Size Inches: Size mm: Stitch Count:
 4.50 X 3.56 in. 114.3 X 90.4 mm 4137 St.

- 1. Medium Gold Detail 0824
- 2. Light Gold Detail 0811
- 3. Dark Gold Detail 0922

Note: Some designs in this collection may have been created using unique special stitches and/or techniques. To preserve design integrity when rescaling or rotating designs in your software, always rescale or rotate designs using the handles directly on-screen.

82028-23 Dresden Daisies Vine 5

Size Inches: Size mm: Stitch Count:
5.56 X 4.52 in. **141.2 X 114.8 mm** **6900 St.**

- 1. Light Green Detail 5230
- 2. Medium Green Detail 5210
- 3. Dark Green Detail..... 5100



82028-24 Dresden Butterfly

Size Inches: Size mm: Stitch Count:
4.06 X 4.77 in. **103.1 X 121.2 mm** **8374 St.**

- 1. Light Blue Detail 3820
- 2. Dark Blue Detail 3611
- 3. Medium Blue Detail 3722

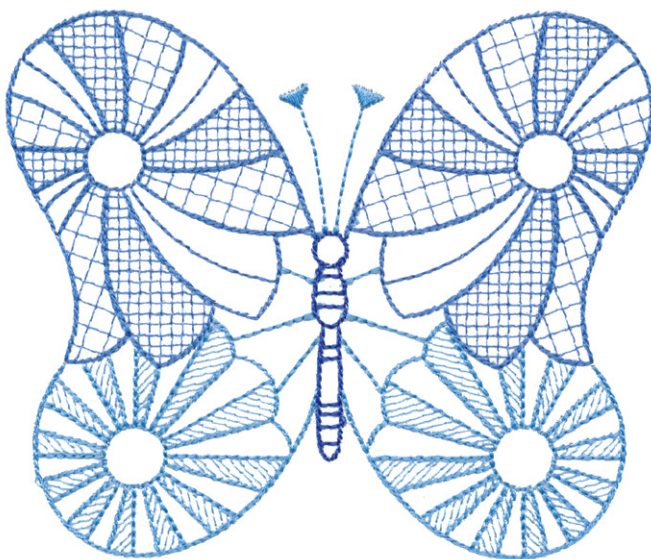

Note: Some designs in this collection may have been created using unique special stitches and/or techniques. To preserve design integrity when rescaling or rotating designs in your software, always rescale or rotate designs using the handles directly on-screen.

82028-25 Dresden Ladybug

Size Inches: Size mm: Stitch Count:
3.01 X 2.37 in. **76.5 X 60.2 mm** **2791 St.**

- 1. Dark Gold Detail 0922
- 2. Light Gold Detail.....0811
- 3. Medium Gold Detail..... 0824

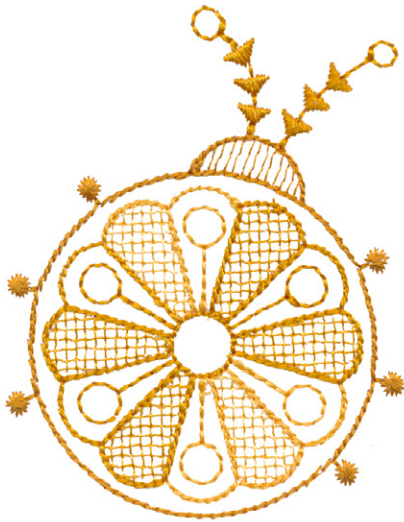

82028-26 Dresden Half

Size Inches: Size mm: Stitch Count:
2.55 X 5.07 in. **64.8 X 128.8 mm** **3710 St.**

- 1. Light Blue Detail 3820
- 2. Medium Blue Detail 3722

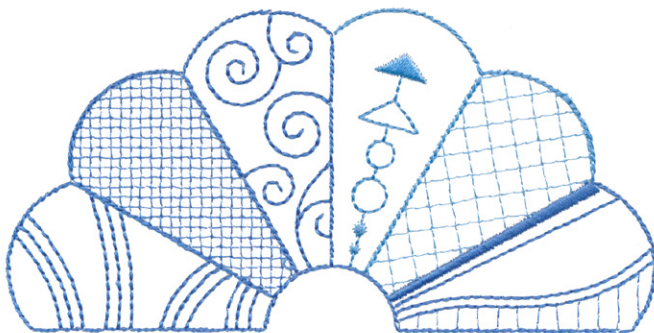

Note: Some designs in this collection may have been created using unique special stitches and/or techniques. To preserve design integrity when rescaling or rotating designs in your software, always rescale or rotate designs using the handles directly on-screen.

82028-27 Vine Accent 1

Size Inches:	Size mm:	Stitch Count:
5.76 X 4.26 in.	146.3 X 108.2 mm	5855 St.

■ 1. Single Color Design..... 3722

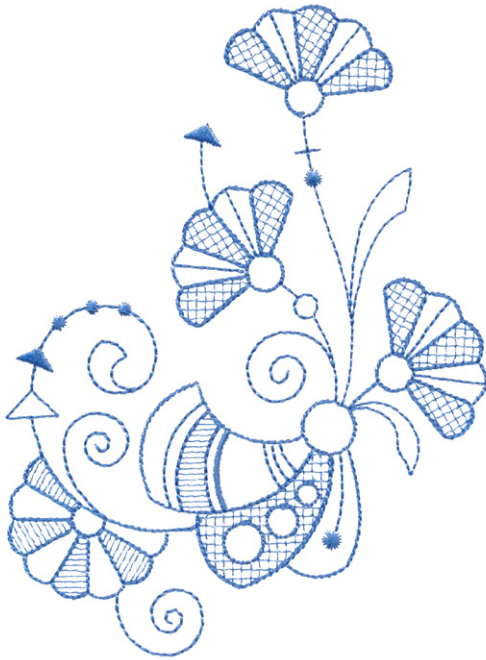

82028-28 Vine Accent 2

Size Inches:	Size mm:	Stitch Count:
5.82 X 3.71 in.	147.8 X 94.2 mm	3903 St.

■ 1. Single Color Design..... 0824

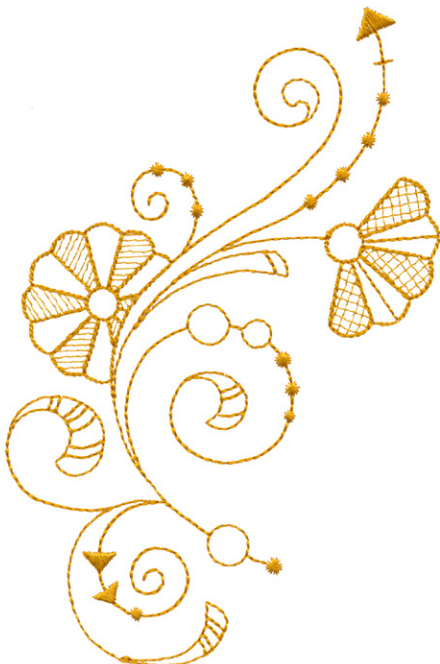

Note: Some designs in this collection may have been created using unique special stitches and/or techniques. To preserve design integrity when rescaling or rotating designs in your software, always rescale or rotate designs using the handles directly on-screen.

82028-29 Vine Accent 3

Size Inches:	Size mm:	Stitch Count:
3.88 X 4.92 in.	98.6 X 125.0 mm	3687 St.

■ 1. Single Color Design..... 5210



82028-30 Vine Accent 4

Size Inches:	Size mm:	Stitch Count:
3.89 X 2.83 in.	98.8 X 71.9 mm	3169 St.

■ 1. Single Color Design..... 1521



Note: Some designs in this collection may have been created using unique special stitches and/or techniques. To preserve design integrity when rescaling or rotating designs in your software, always rescale or rotate designs using the handles directly on-screen.

82028-31 Vine Accent Mini

Size Inches:	Size mm:	Stitch Count:
2.53 X 1.63 in.	64.3 X 41.4 mm	1221 St.

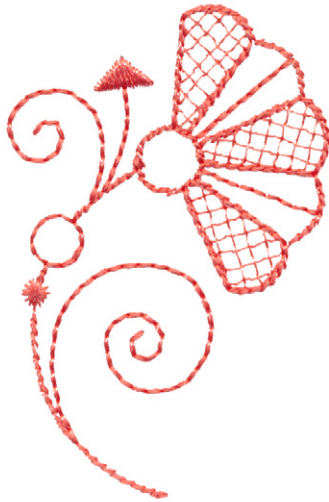

- 1. Single Color Design..... 1521

82028-32 Half Dresden Border

Size Inches:	Size mm:	Stitch Count:
7.02 X 1.19 in.	178.3 X 30.2 mm	3848 St.

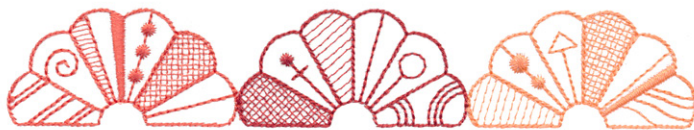

- 1. Medium Red Detail..... 1521
- 2. Dark Red Detail..... 1725
- 3. Light Red Detail..... 1352

Note: Some designs in this collection may have been created using unique special stitches and/or techniques. To preserve design integrity when rescaling or rotating designs in your software, always rescale or rotate designs using the handles directly on-screen.

82028-33 Half Dresden Corner



Size Inches:	Size mm:	Stitch Count:
3.52 X 3.52 in.	89.4 X 89.4 mm	3260 St.
■ 1. Medium Red Detail.....		1521
■ 2. Dark Red Detail.....		1725
■ 3. Light Red Detail.....		1352

82028-34 Dresden Mini Border

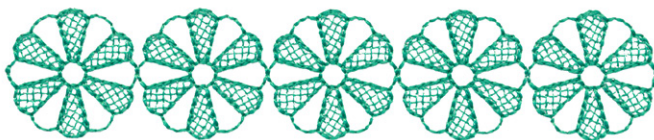

Size Inches:	Size mm:	Stitch Count:
1.01 X 5.02 in.	25.7 X 127.5 mm	3812 St.
■ 1. Single Color Design.....		5210

Note: Some designs in this collection may have been created using unique special stitches and/or techniques. To preserve design integrity when rescaling or rotating designs in your software, always rescale or rotate designs using the handles directly on-screen.

82028-35 Dresden Daisy Mini

Size Inches:	Size mm:	Stitch Count:
1.29 X 1.29 in.	32.8 X 32.8 mm	1275 St.

■ 1. Single Color Design..... 5210

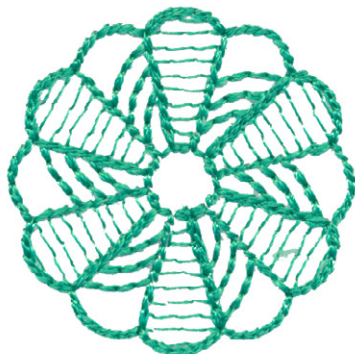

PROJECT SUPPLIES



Stabilizers

- Fusible Woven (20" preferred)
- Applique Fuse and Fix
- Ultra Clean and Tear Fusible
- StabilStick CutAway

Supplies

- Lightweight Denim
 - Outer bag fabric 21" x 36"
 - Pocket fabric 10" x 12"
- Lining fabric, 21" x 36"
- Outer base fabric (leather, vinyl, Kraf-tex)
 - Bottom fabric 21" x 11"
 - Trim 42" x 2" (may be sewn or glued together)
- Scraps for appliques



Notions

- Isacord thread per thread chart (or to coordinate with fabric)
- Perfect Embroidery Press Cloth
- Webbing (for handle) 1" x 3 yards
- Quilter's ruler
- Chalk or other removable fabric marker
- Water-soluble glue stick
- Scissors
- Sewing Machine (recommended dual feed foot, zipper foot, edge stitch foot)

Hoops

- Large Oval for pocket design
- Maxi or Jumbo for front design (Alternatively, combine smaller designs.)

STEP 1

- Using an ink jet printer, print Mirrored Templates onto the paper side of the Applique Fuse and Fix using the mirrored templates found in the Sewing Instructions PDF.
- Roughly cut out templates and fuse to the back the appropriate applique fabrics.



STEP 2

- Cut out appliques along the outer edge of the design line.
- Set aside.

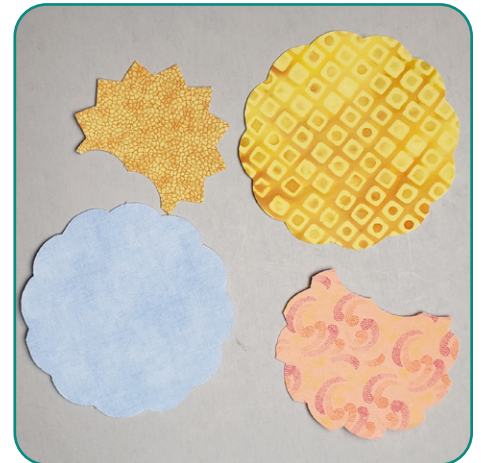

STEP 3

- Apply Fusible Woven to the wrong sides of the Outer Pocket and Lining fabrics.
- Fusible Woven may also be applied to the wrong side of the leather for the base of the bag if it needs more stability.
- Note: Center the Fusible Woven and apply down the length of the fabric. About 1/2" of the fabric on each side will not be covered.



STEP 4

- Fold the fabrics (outer, lining and base) in half wrong sides together. The fold should measure 21" on each fabric.
- On both folded corners (right and left) of each fabric mark a line 3.25" in from the cut edge and 3" up from the fold.



STEP 5

- Cut out each corner through both thicknesses of the fabric.
- These cutouts make the boxed corners of the bag.



STEP 6

- Mark a line on each side 4.5" from the fabric center down the complete 16" length of the denim fabric.
- These lines indicate the inner edge of the handle straps.

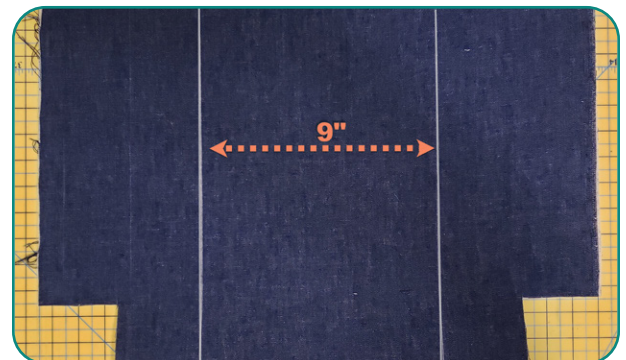

EMBROIDERY



STEP 7

- Mark a line (about 12") down the center of one side of the denim (which is the "front side" in further directions).
- Mark a second line horizontally 7" down from the top of the denim fabric between the two lines marked in Step 6.
- This is the placement for the front design.

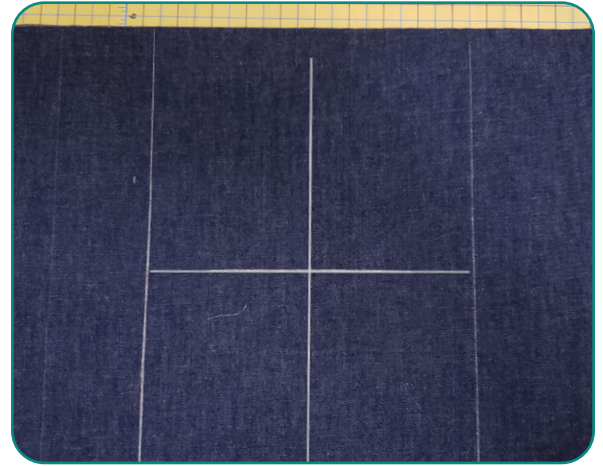

STEP 8

- Fold the pocket in half so the fold line measures 10".
- Mark a line vertically and horizontally in the center of the pocket below the fold line.

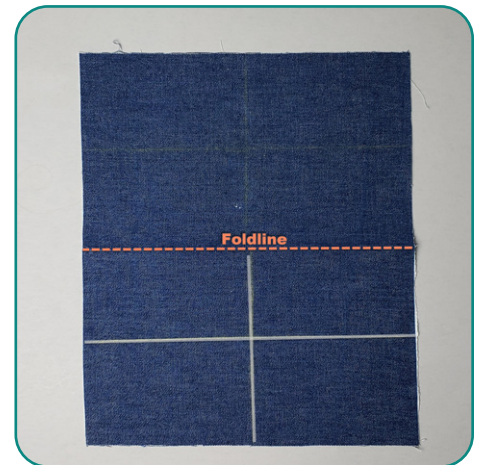

STEP 9

- Fuse a piece of Ultra Clean and Tear Fusible to the wrong side of the front of the bag.



EMBROIDERY



STEP 10

- In a Maxi or Jumbo hoop, hoop a piece of StabilStick CutAway paper side up.
- Score the paper with a stiletto or pin.
- Remove the paper to expose the adhesive surface.



STEP 11

- Position the bag fabric over the hooped stabilizer.
- Use the hoop marks and the drawn lines to center the fabric.
- If desired, use a hoop template to make sure the fabric is straight in the hoop.
- Finger press in place to secure fabric to the stabilizer.

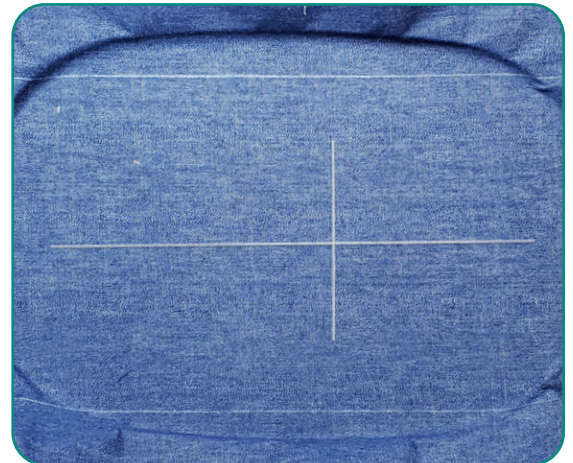

STEP 12

- Load design 82028-02.
- Rotate the design 135° so that it will fit between the marked lines for handle placement.
- Position the hoop so that the needle is centered over the marked crosshair on the fabric.



STEP 13

- If available, use Pinpoint Placement to ensure the design is positioned correctly in the hoop.
- Select the top center point on the grid and adjust until the dropped needle is on the drawn line as shown. Set the point.
- Then select the bottom center point. Adjust the width only until the dropped needle is on the line. Set.
- Select the 'i' for information to exit Pinpoint Placement.
- Select the needle icon to embroider.



STEP 14

- Thread the machine with Isacord 5230 (or the color selected for Machine Step 7). Stitch Machine Step 1, Yellow Fabric Placement Stitch.
- **Note** – it is not necessary to change thread colors until Machine Step 8. All the placement stitches and Cut Line/Tackdown stitches may be done in the same thread as they will be covered with satin stitches later.



STEP 15

- Peel the paper from the back of the yellow applique fabric to expose the sticky surface. Position the applique on the fabric using the placement stitch as a guide. Finger press to secure.
- Stitch Machine Step 2, Cutline and Tackdown.
- **Tip** – To easily remove the paper from the back of the fabric prepared with Applique Fuse and Fix, score the paper with a stiletto, pin, or scissor point.

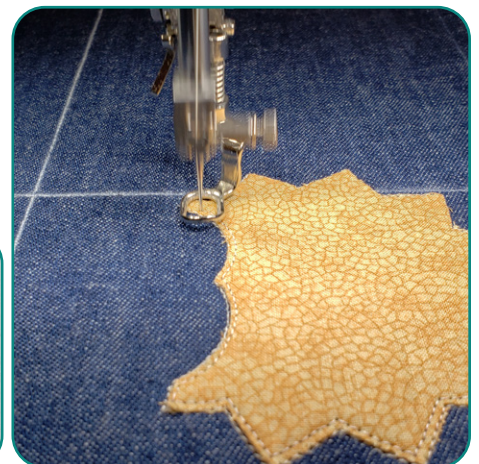

STEP 16

- Stitch Machine Step 3, Red Fabric Placement Stitch.

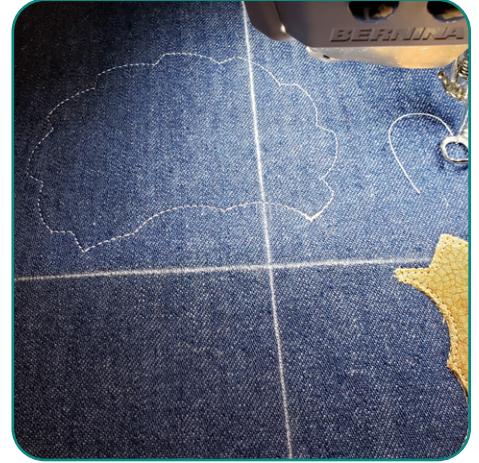

STEP 17

- Remove the paper backing and position the red applique fabric in the placement stitch.
- Stitch Machine Step 4, Cutline and Tackdown.



STEP 18

- Stitch Machine Step 5, Blue Fabric Placement Stitch.

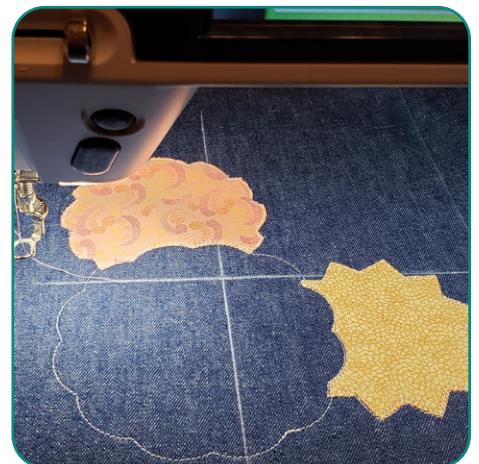

EMBROIDERY



STEP 19

- Remove the paper backing and position the blue applique fabric in the placement stitch.
- Stitch Machine Step 6, Cut Line and Tackdown.



STEP 20

- Stitch Machine Step 7, Light Green Detail.
- Continue to embroider the design changing thread colors with each Machine Step as per the color chart.



POCKET EMBROIDERY



STEP 21

- Hoop StabilStick CutAway in the large oval hoop. Score paper and tear away to expose the sticky surface.



STEP 22

- Center the marked side of the unfolded pocket fabric in the hoop. Finger press to secure.
- Place the hoop onto the machine.

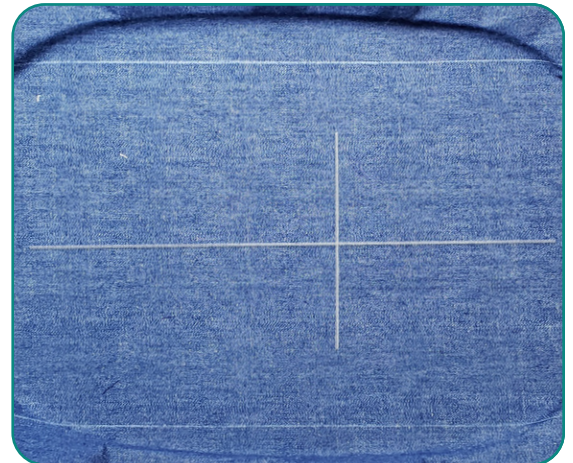

STEP 23

- Load design 82028-08 into the machine.
- Thread the machine with Isacord 0811 (or the color for Machine Step 3).
- Move the hoop until the needle is centered over the center of the drawn crosshair on the fabric as shown.



POCKET EMBROIDERY



STEP 24

- Stitch Machine Step 1, Yellow Fabric Placement Line.

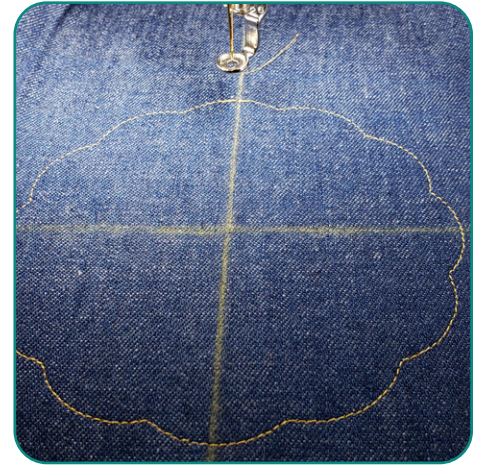

STEP 25

- Remove the paper backing from the applique fabric. Position the fabric in the placement line.
- Stitch Machine Step 2, Cut Line and Tackdown.



STEP 26

- Finish embroidering the remaining colors of the design.



POCKET EMBROIDERY



STEP 27

- On both embroidered pieces, carefully trim the cut-away stabilizer about 1/4" away from the design area as shown.
- Also tear away any large pieces of Ultra Clean and Tear. It does not matter if some is left fused to the back of the fabric.



ASSEMBLY



STEP 28

- Mark a horizontal line 6.5" below the top of the back (unembroidered) side of the bag.

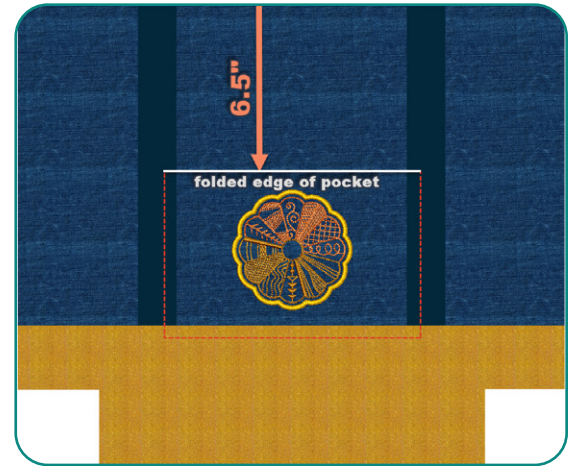

STEP 29

- Align the folded edge of the embroidered pocket with the marked line. The sides should be slightly over the vertical strap lines (see Step 6) and slightly below the edge where the bottom will be stitched down.
- Use a glue stick under the three raw edges to hold the pocket in place.



STEP 30

- At the sewing machine, secure the three raw edges to the bag with a zigzag stitch along the edge as shown.



ASSEMBLY



STEP 31

- Mark a line between the top of the cutout for the boxed bottom on each side.
- Position one end of the strap with the newly marked line and with the right edge on the strap placement line (Step 6). Pin to secure. Mark a stopping place 1" from the top of the bag.
- Smooth out the strap so it is not twisted and pin the right side in the same manner; this time the left edge of the strap will align with the strap placement line.



STEP 32

- Using a dual feed zipper foot (or similar). Stitch the strap to the side of the bag close to one edge. Stop 1" from the top edge of the bag. At this point, stitch across the strap horizontally and down the other side to the bottom edge. Secure the other side of the strap in the same manner.
- The vertical sides of the pocket should be caught under the strapping.
- Note: It is a good idea to give the bottom and top edges a bit of reinforcement by stitching a box with an "x" inside or a row or two of zigzag stitches.



STEP 33

- Repeat steps 32-33 for the front side of the bag.

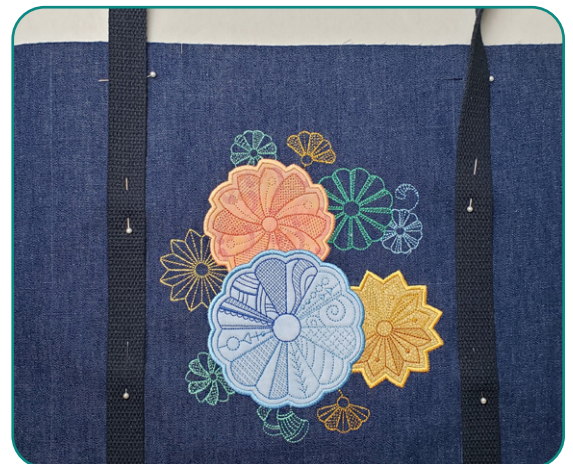

ASSEMBLY



STEP 34

- Lay the outer bag on a flat surface. Position the bottom fabric in place, matching the openings for the corners. Clip or pin to secure.
- Use a zigzag stitch along the three inner edges to secure the bottom fabric to the bag on both sides.

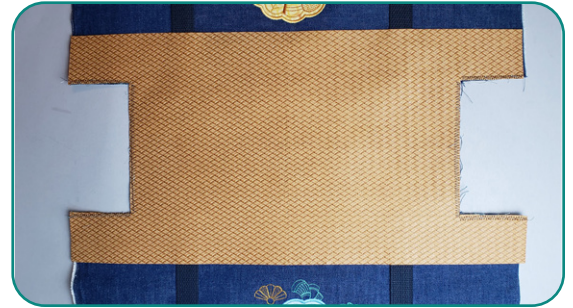

STEP 35

- Fold back the horizontal edge of the bottom fabric back. Rub some glue along the raw edge.
- Fold back into place and finger press to secure in place.
- Repeat on the other side.



STEP 36

- Using an edge stitch foot, stitch the horizontal length of each side of the base fabric with a single run blanket stitch.



ASSEMBLY



STEP 37

- With right sides together and a 1/4" seam allowance, stitch the two sides of the bag together. Overlock the seams if desired. Press the seams to the side. Repeat for the lining.
- Create the corners by matching the seam with the center of the long side of the cutout as shown. Stitch with a 1/4" seam allowance. Repeat for all corners of the bag and lining.



STEP 38

- Turn the bag right side out. Insert the lining into the bag (do not turn the lining inside out). Match the side seams and pin.
- Pin around the top of the bag to secure the lining to the bag.
- Stitch the lining and bag together with a 1/4" seam allowance. Keep the strapping out of the way, as shown.



STEP 39

- Starting near the middle of one side edge, stitch the binding to the bag with a 1/2" seam allowance.
- Trim the ends with a 1/4 - 1/2" overlap. Glue the overlap together.



ASSEMBLY



STEP 40

- Fold the binding over the top edge of the bag to the back. Clip to hold.
- Using an edge stitch foot or a zipper foot, stitch on the front of the bag close to, but not on, the binding.
- For more attractive results, use a top thread that matches the outer bag fabric and a bobbin thread that matches the binding.



APPLIQUE PATTERNS

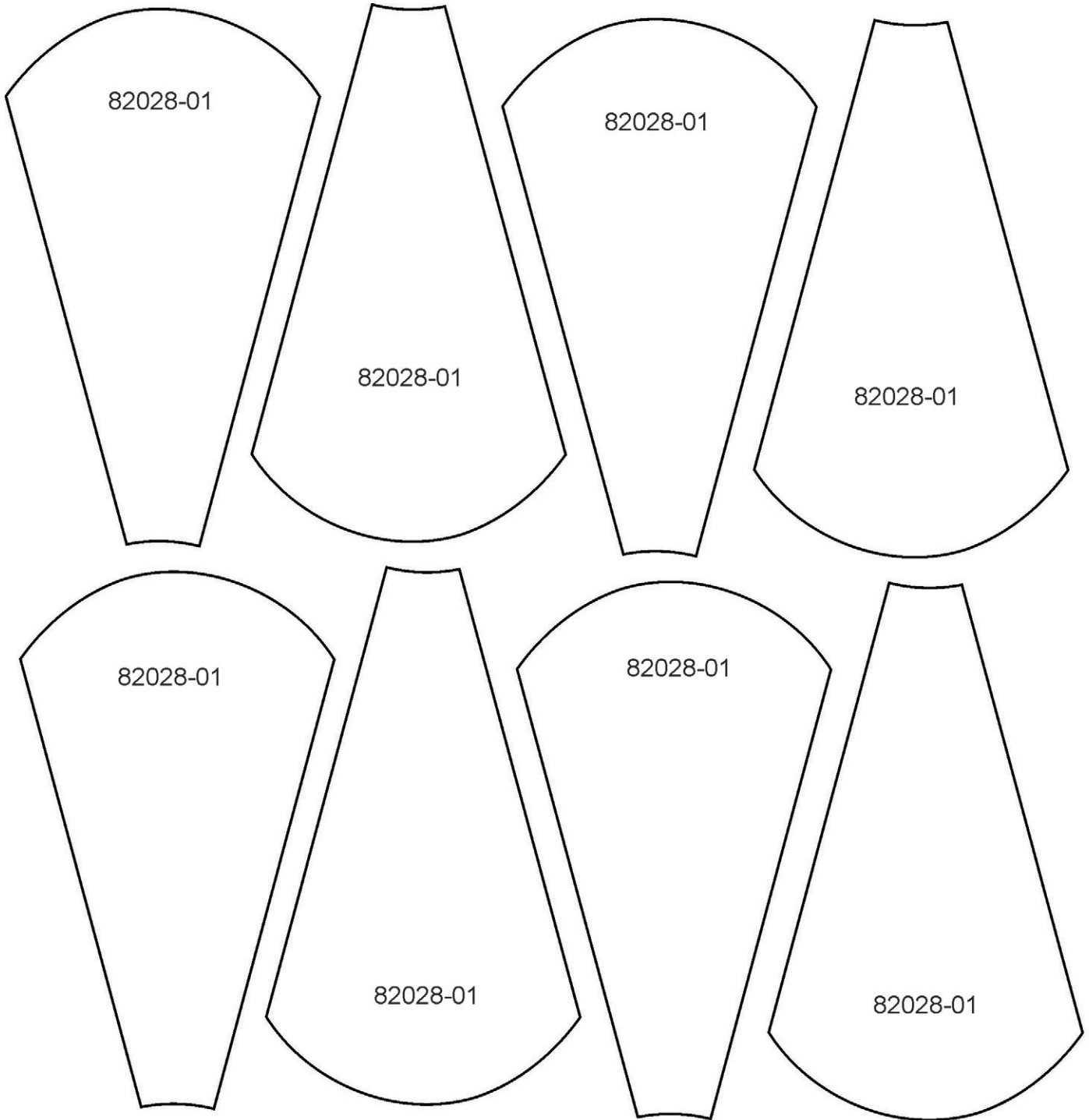

APPLIQUE PATTERNS

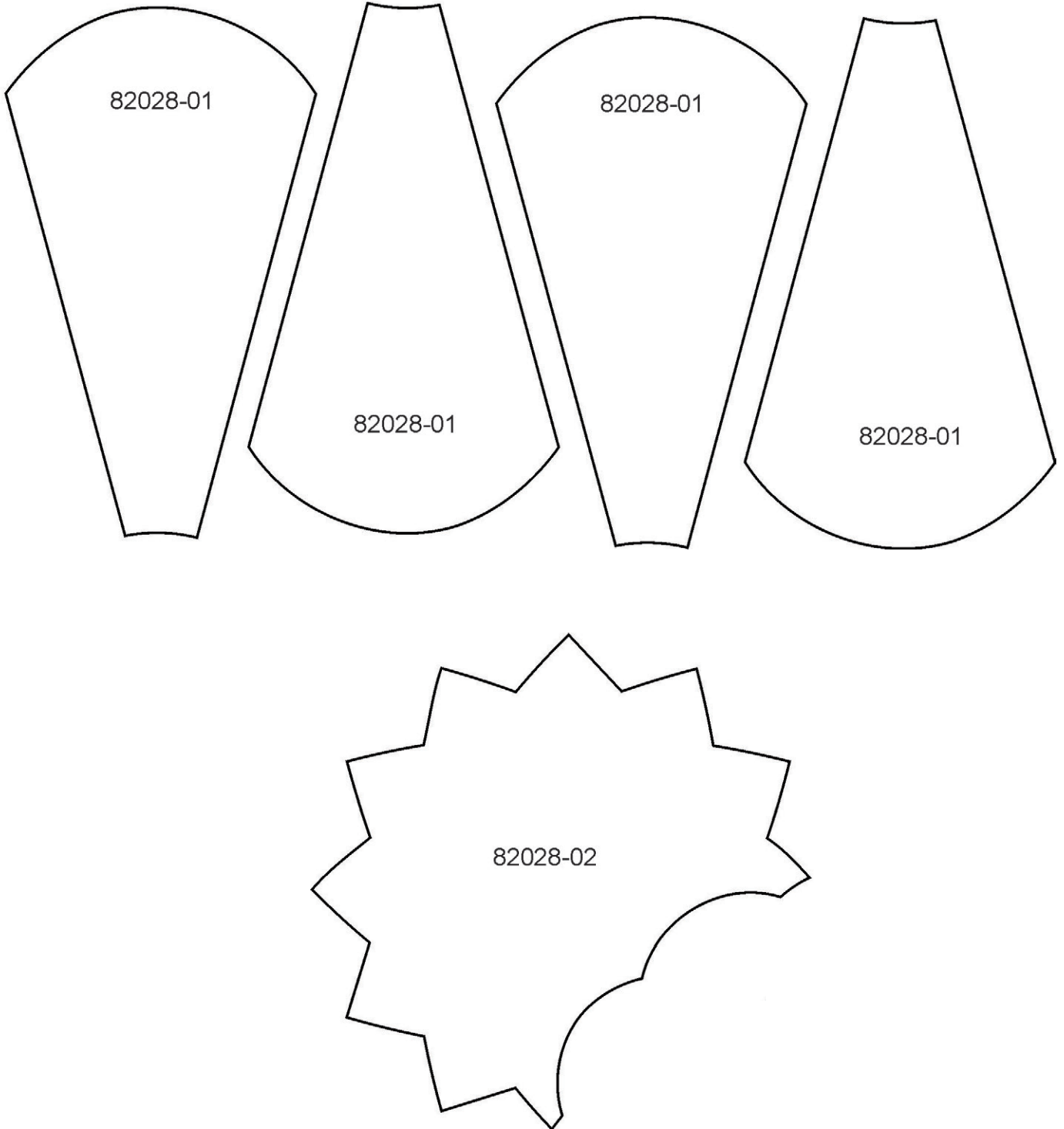

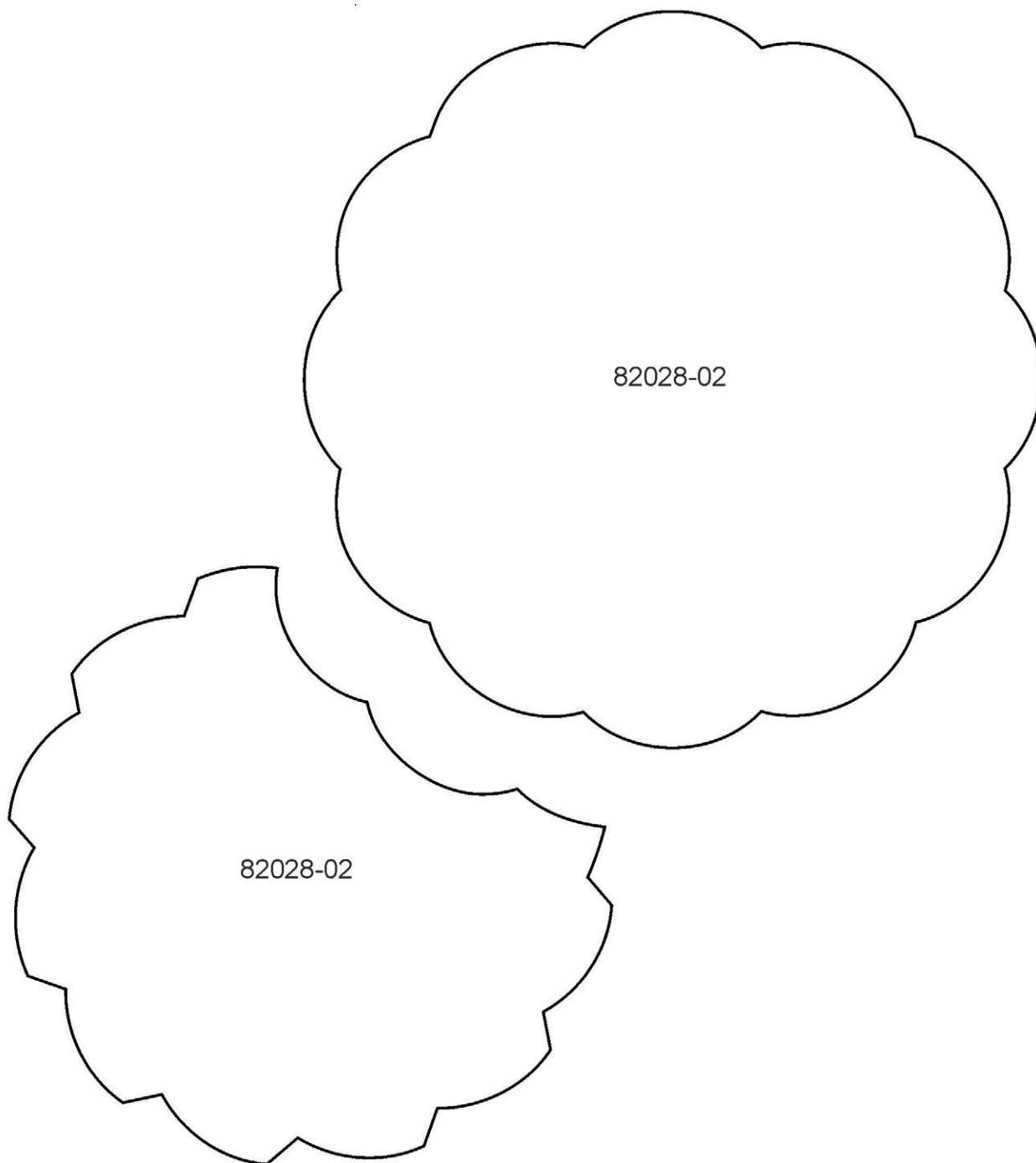

82028-03

APPLIQUE PATTERNS

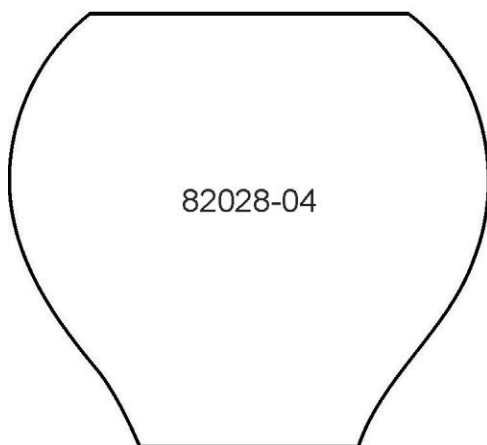
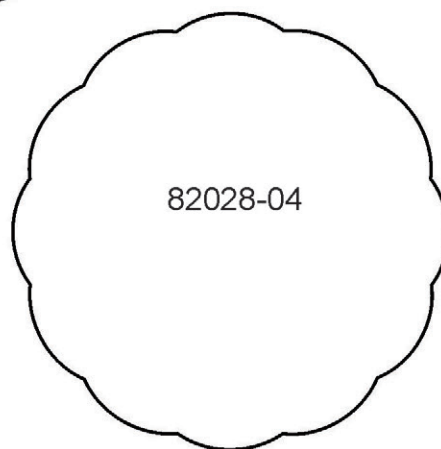
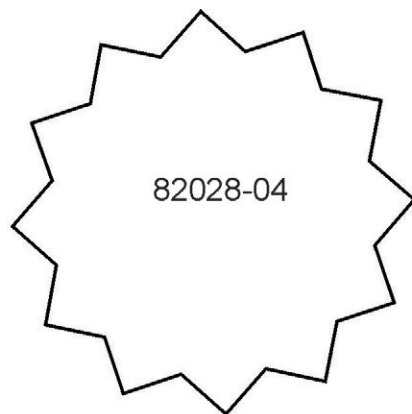

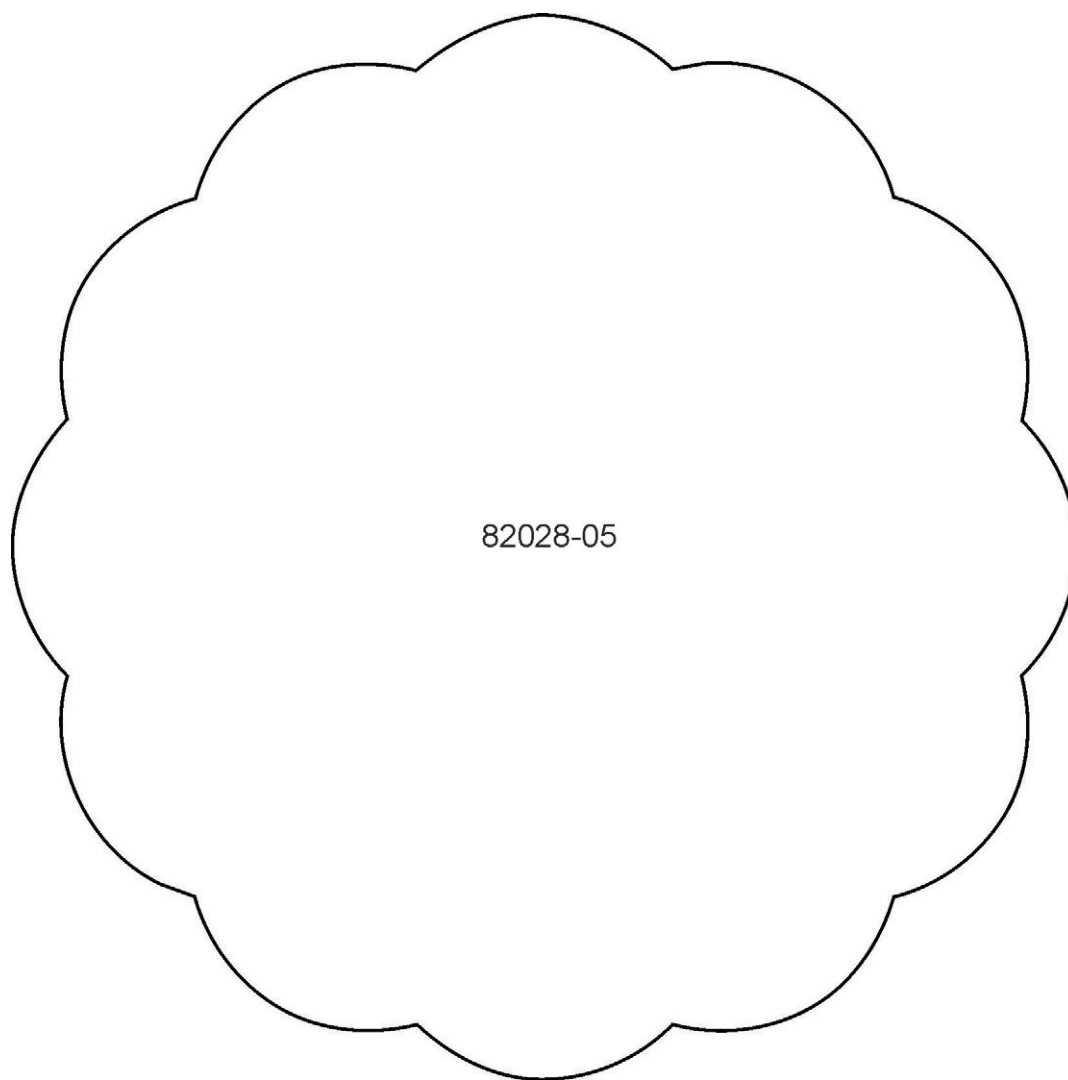

82028-05

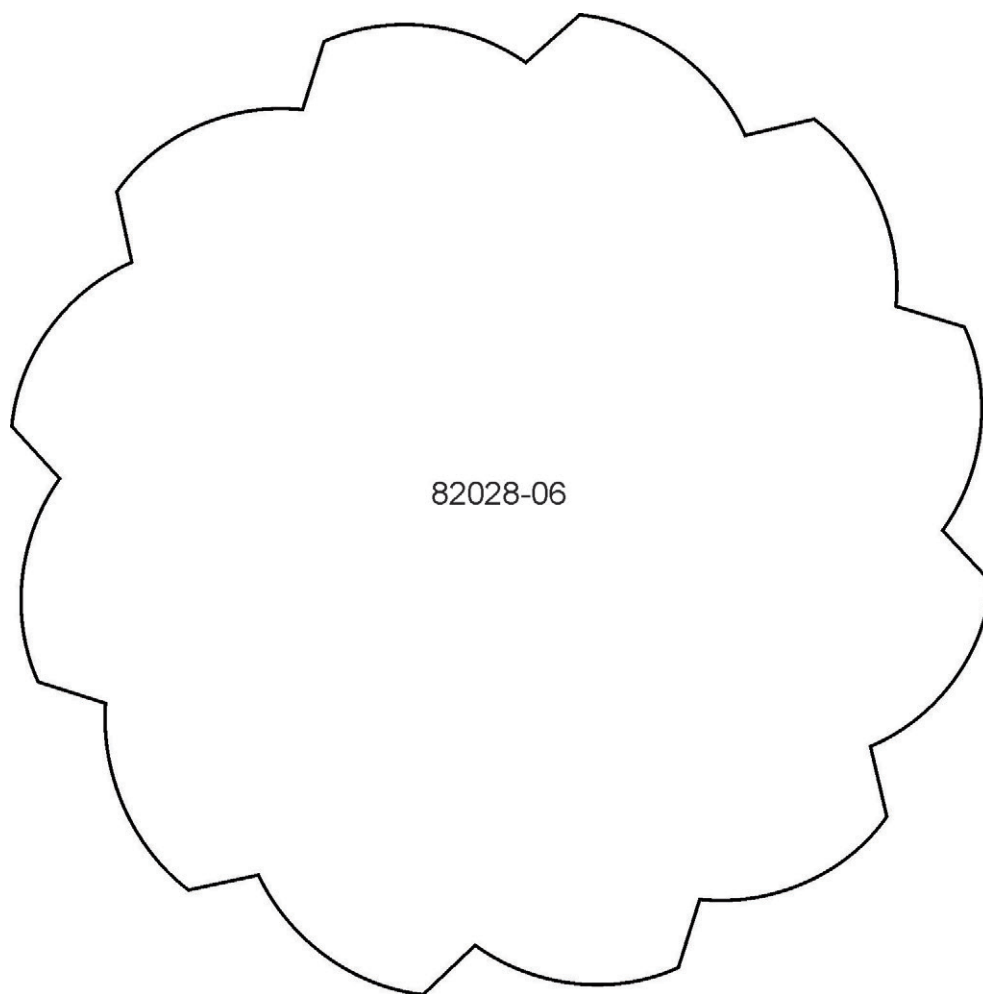

APPLIQUE PATTERNS

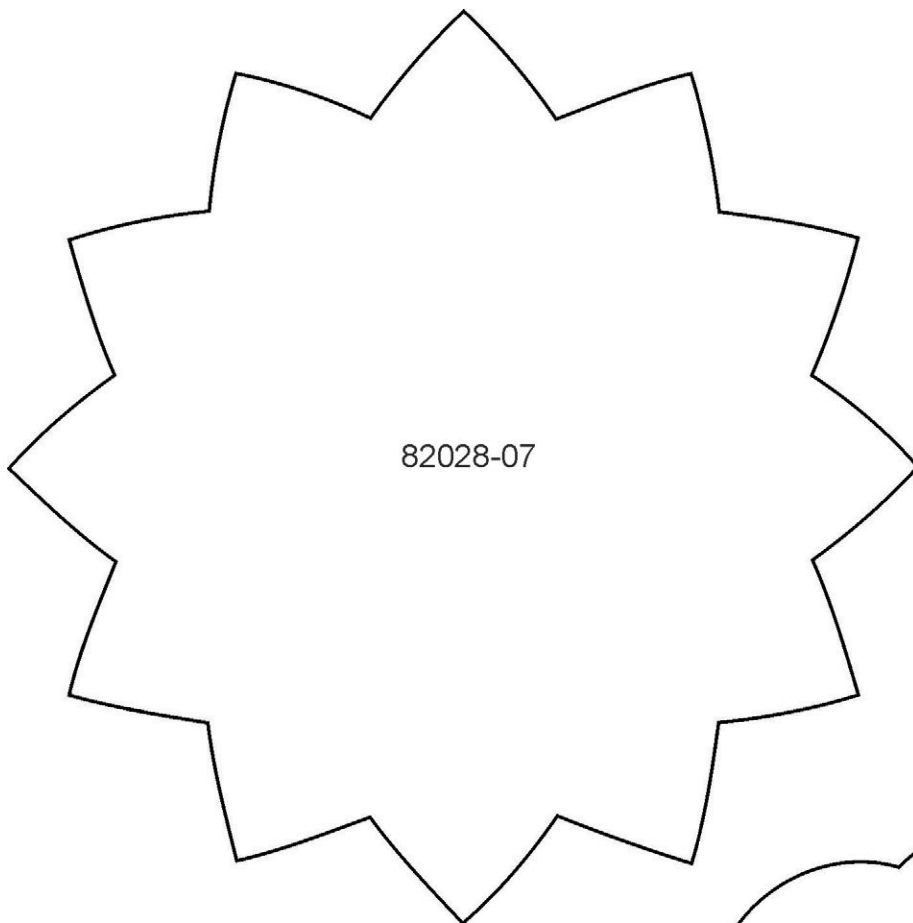

82028-07

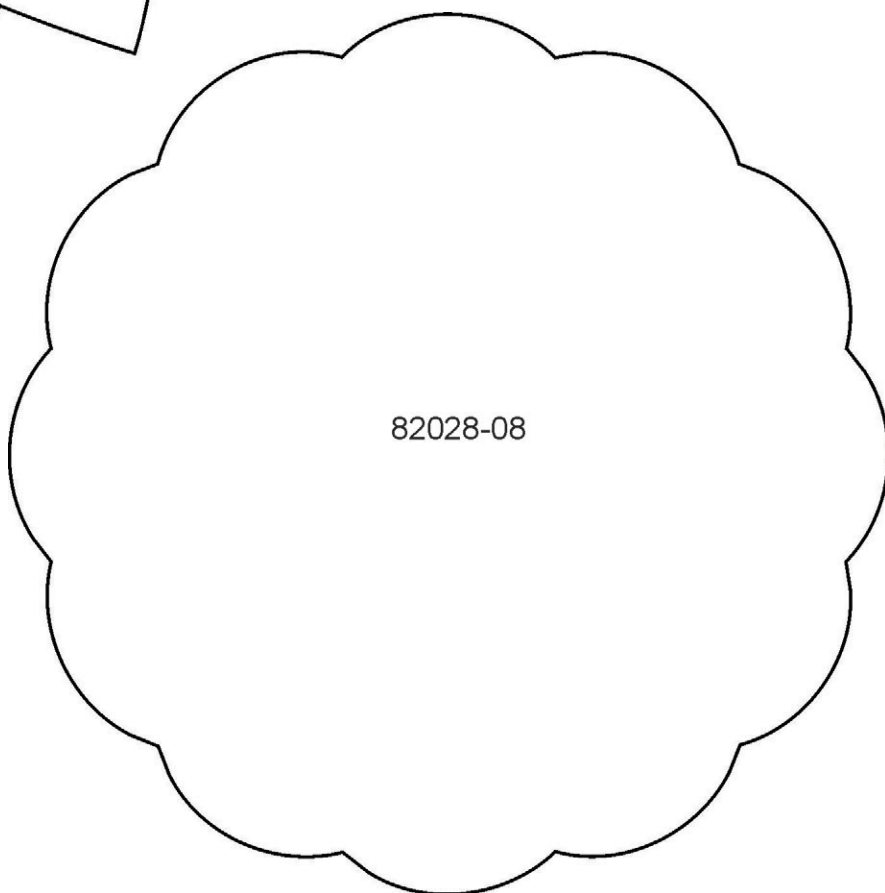

82028-08

APPLIQUE PATTERNS

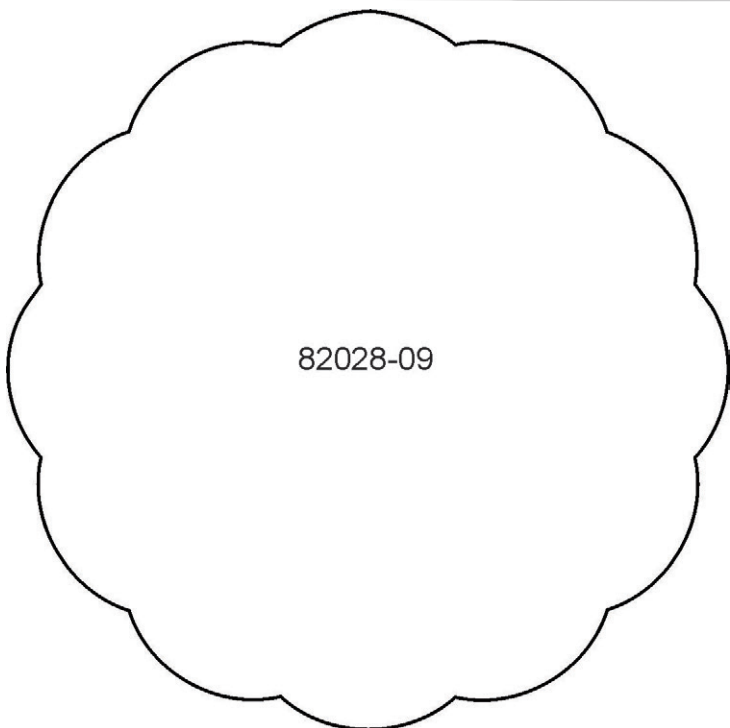

82028-09

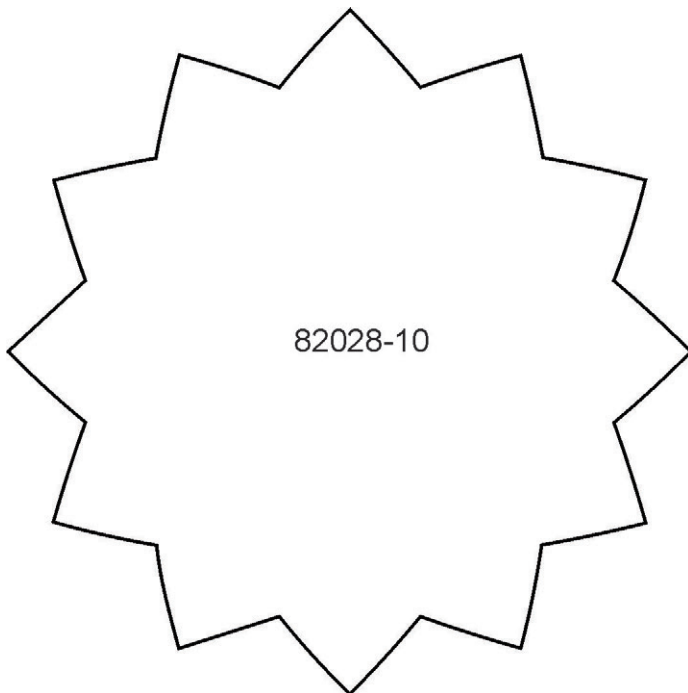

82028-10

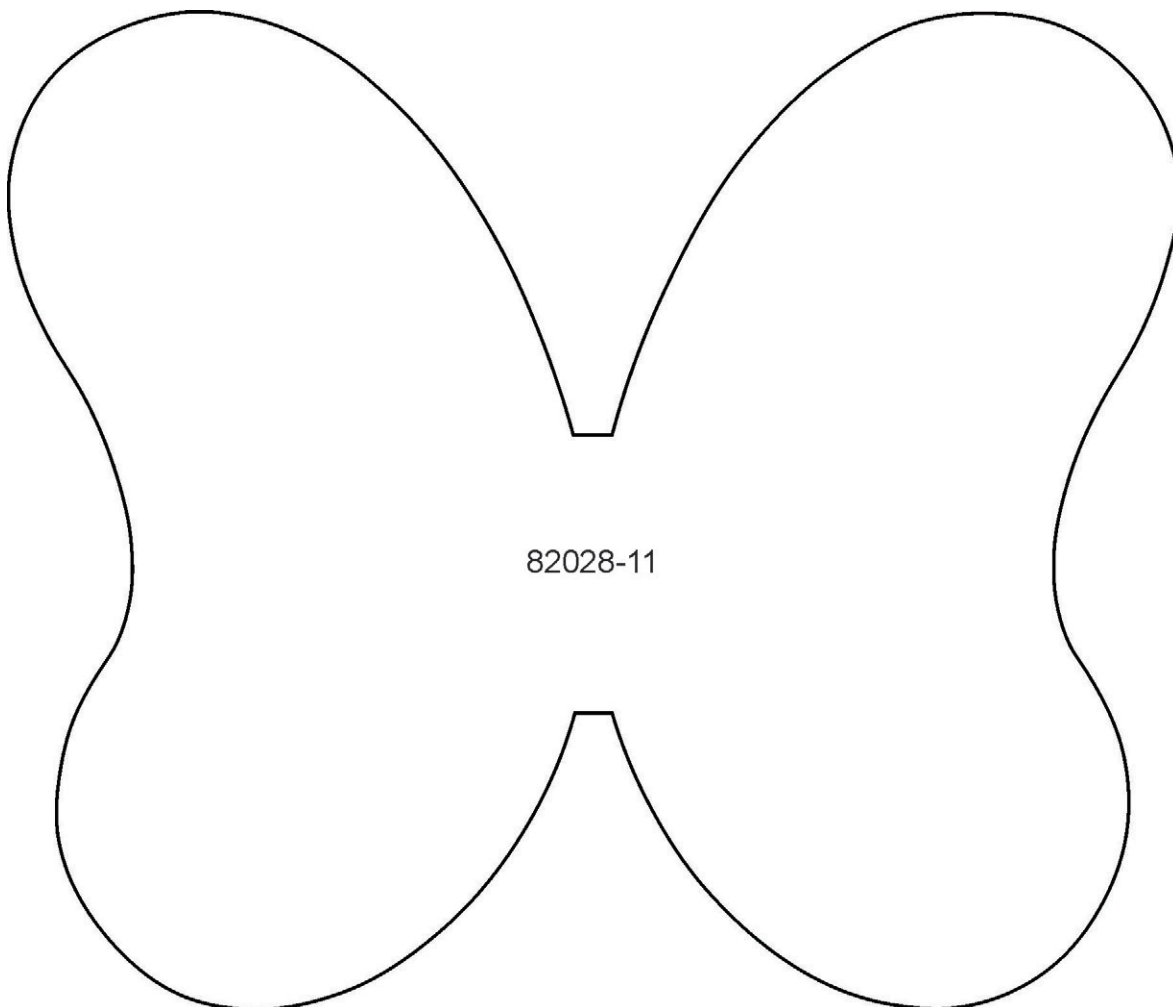

82028-11

APPLIQUE PATTERNS

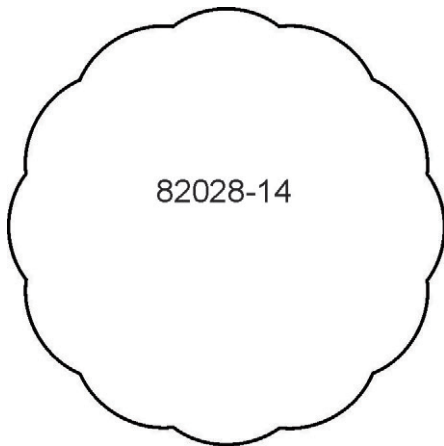
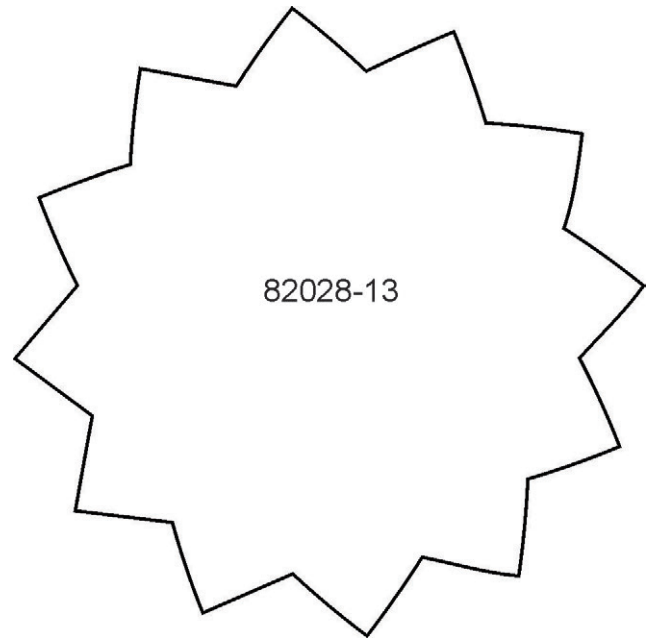
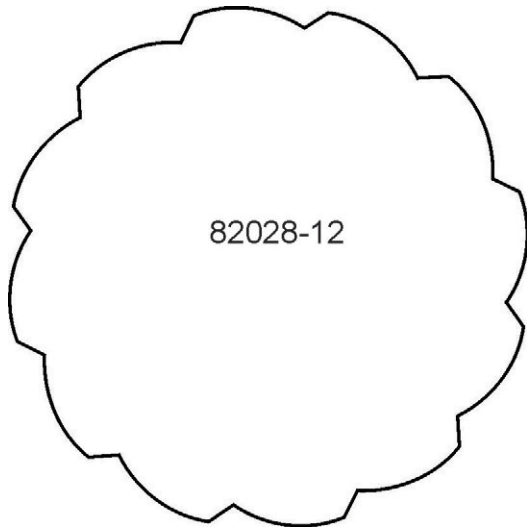

MIRRORED PATTERNS

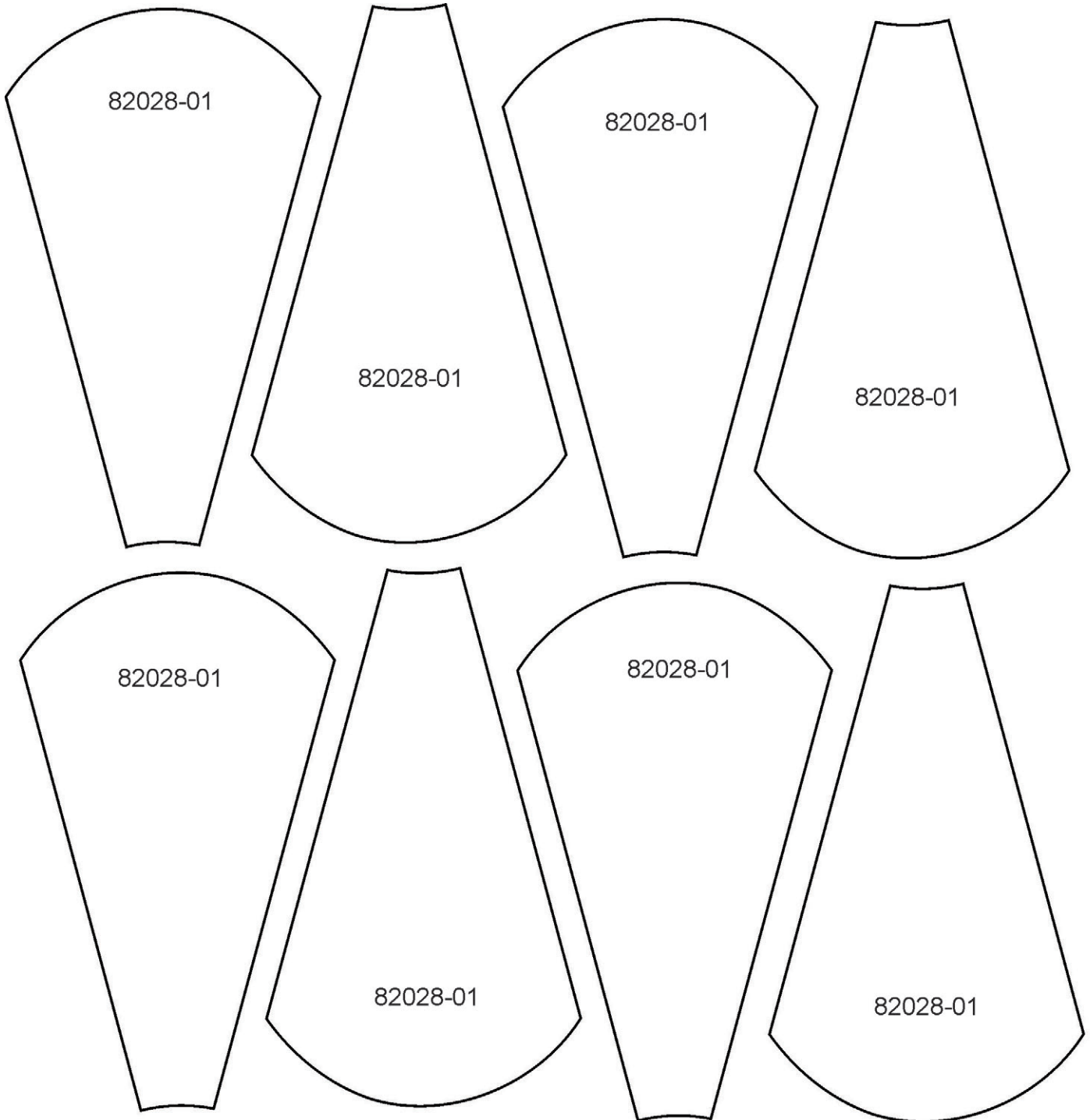

MIRRORED PATTERNS

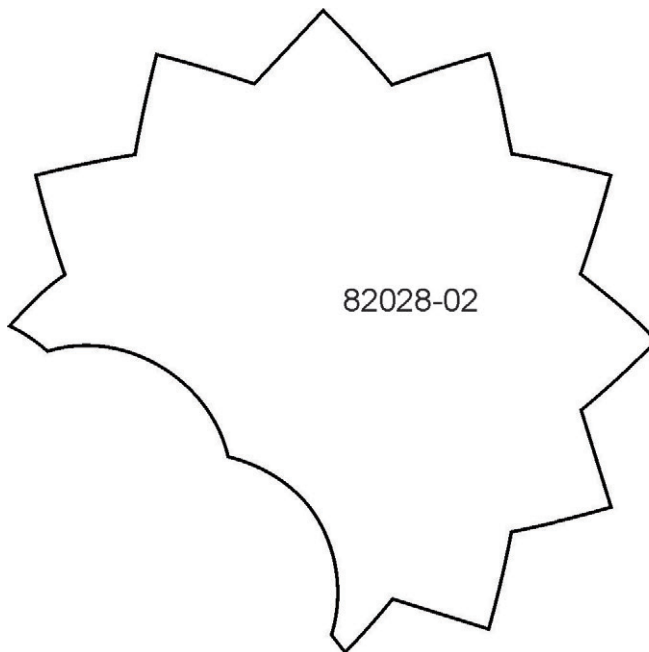
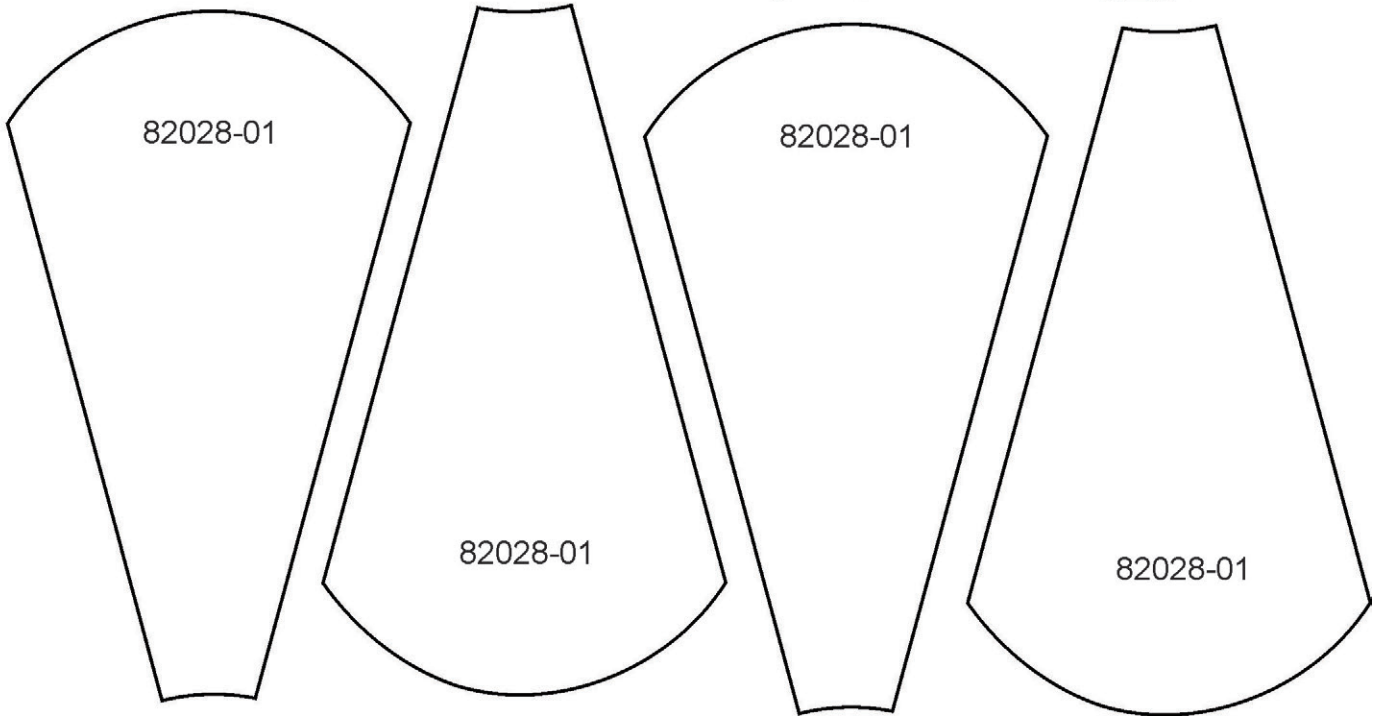

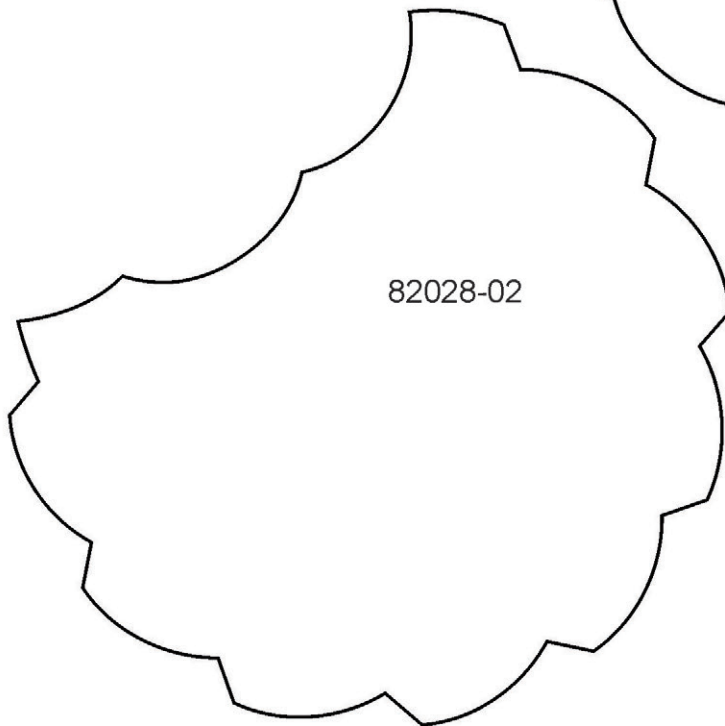
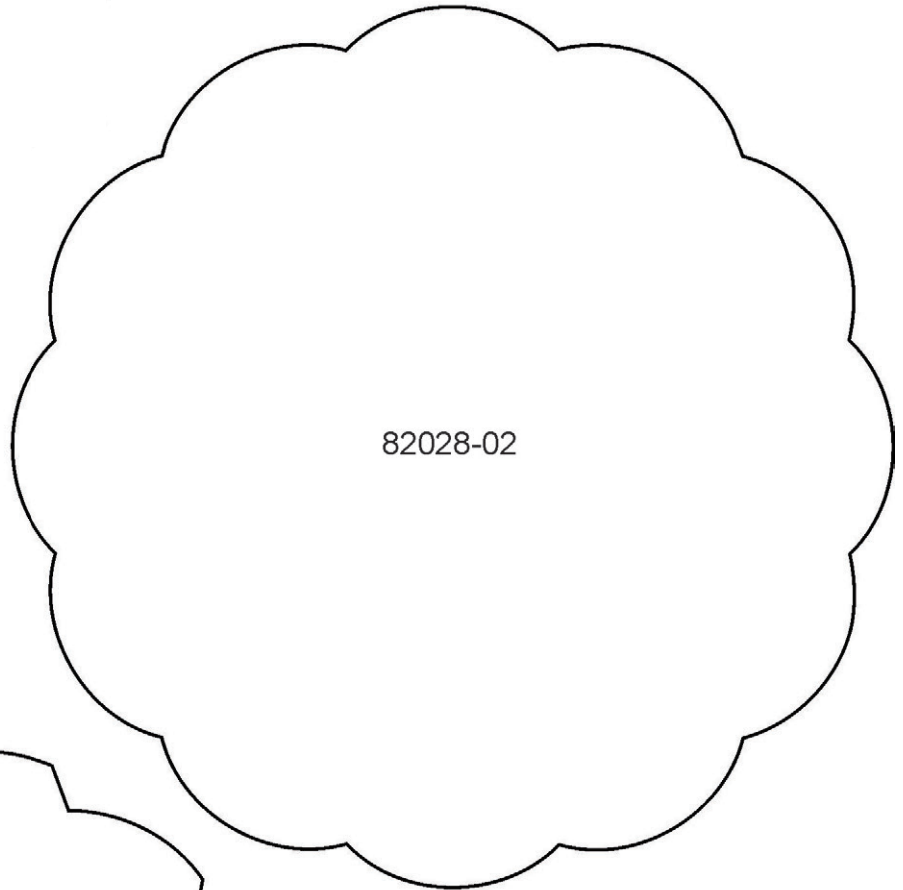

82028-03

MIRRORED PATTERNS

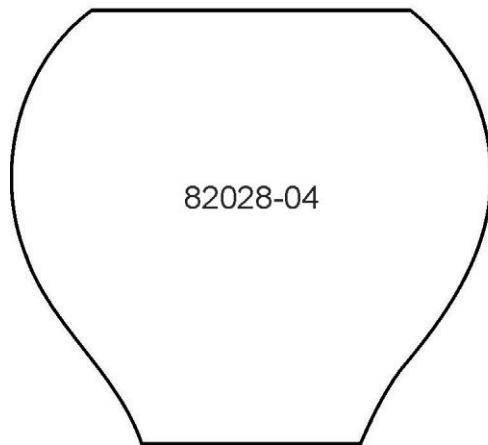
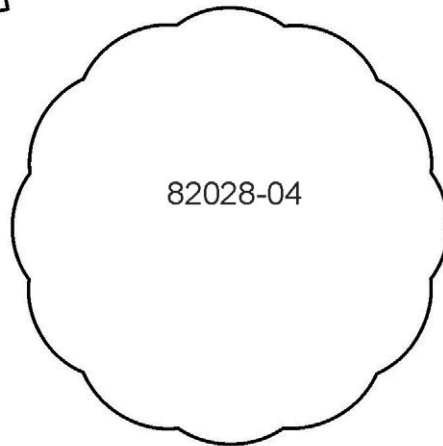

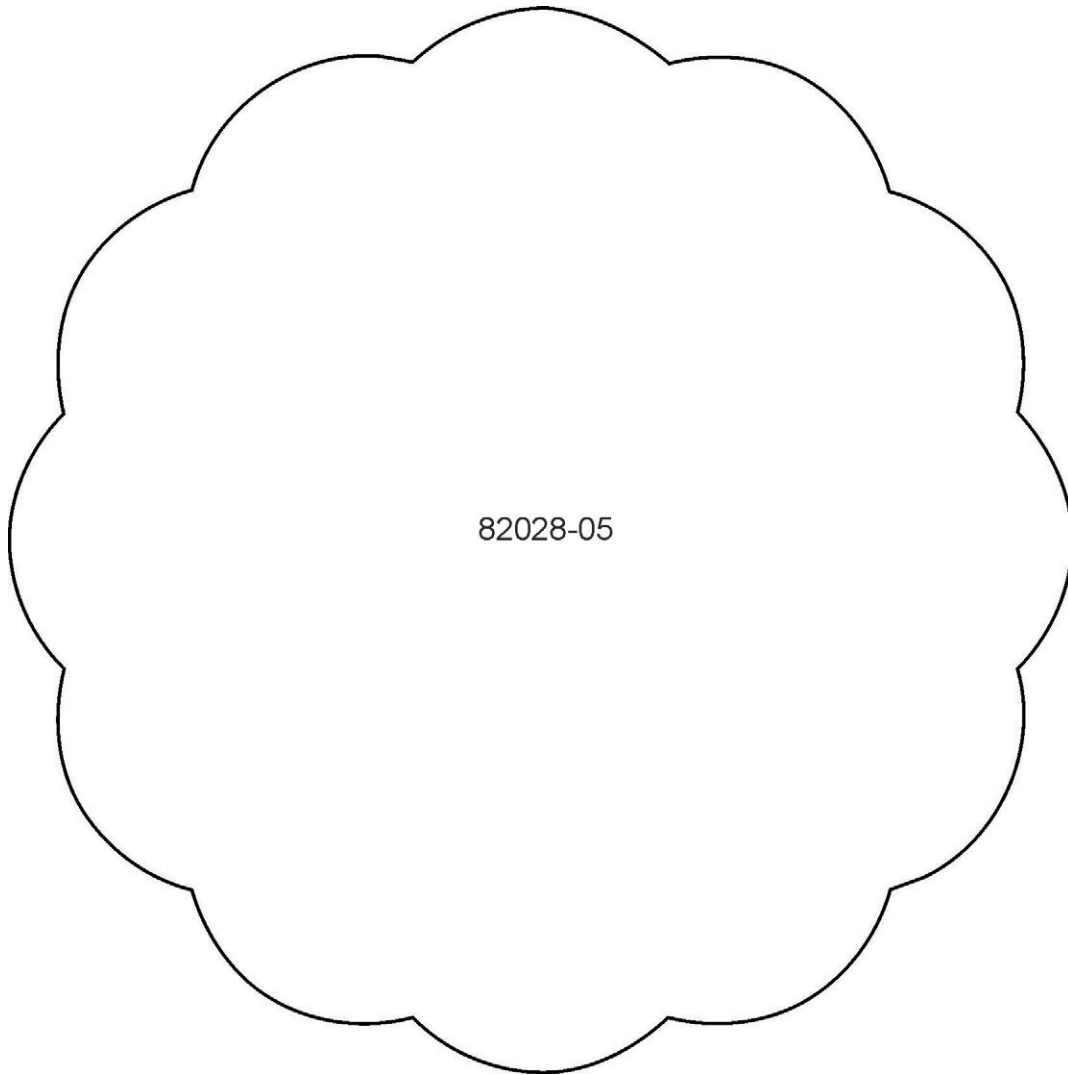

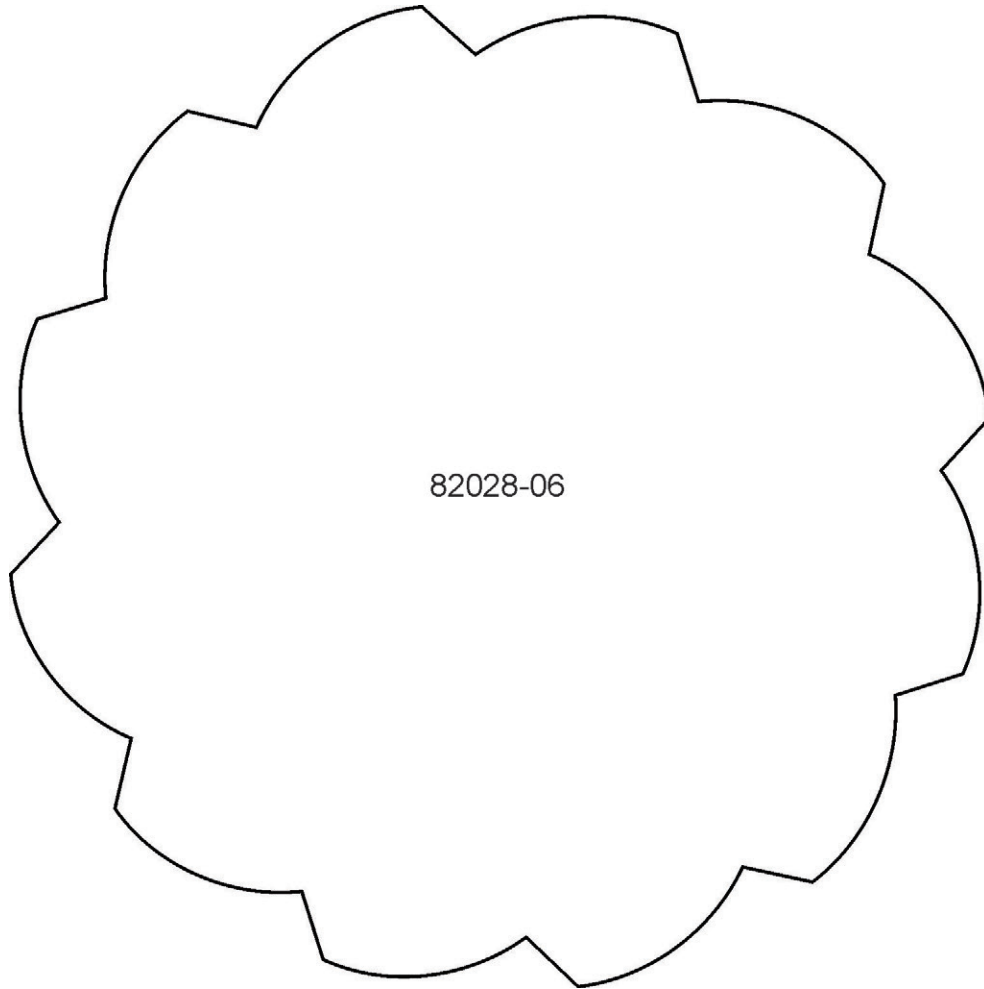

MIRRORED PATTERNS

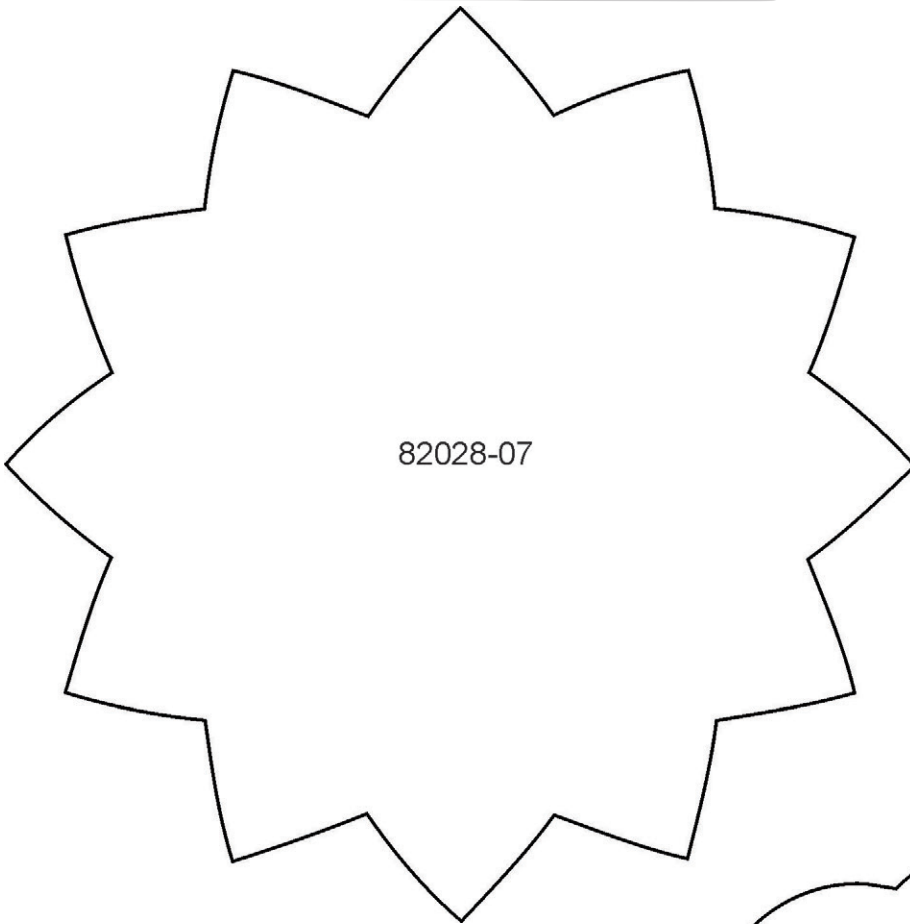

82028-07

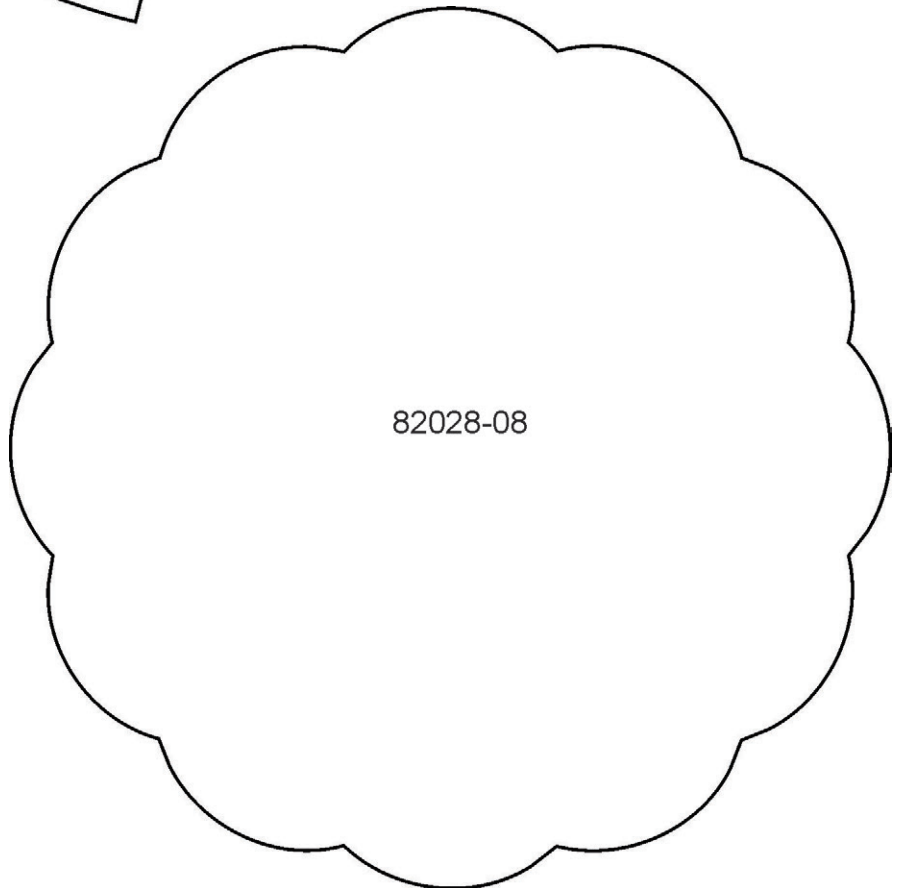

82028-08

MIRRORED PATTERNS

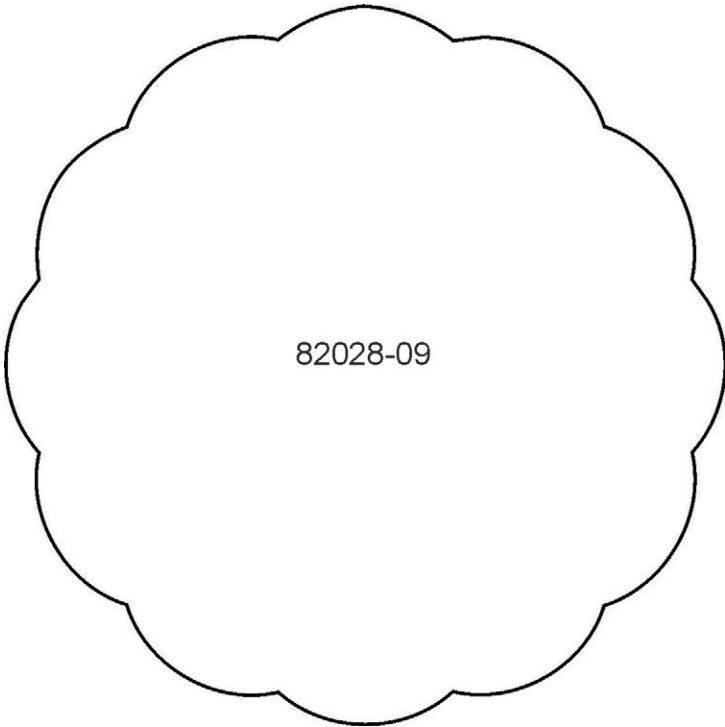

82028-09

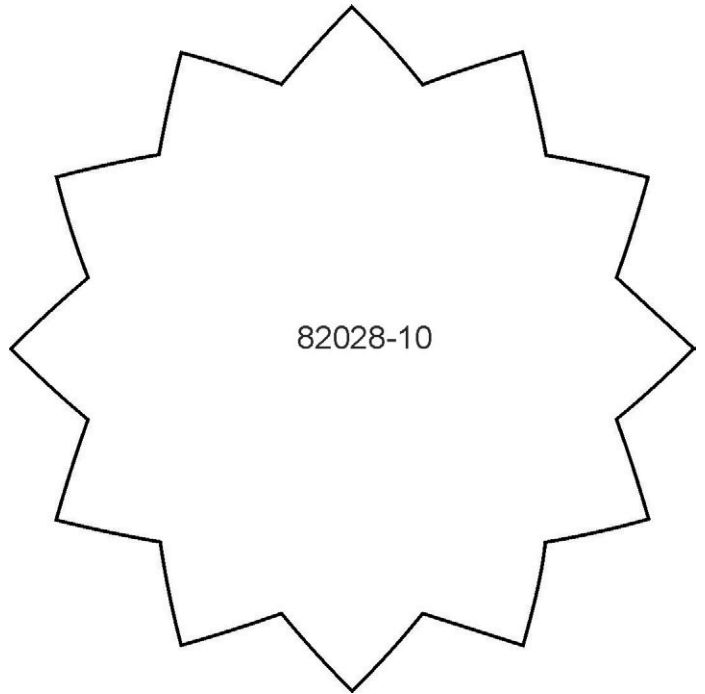

82028-10

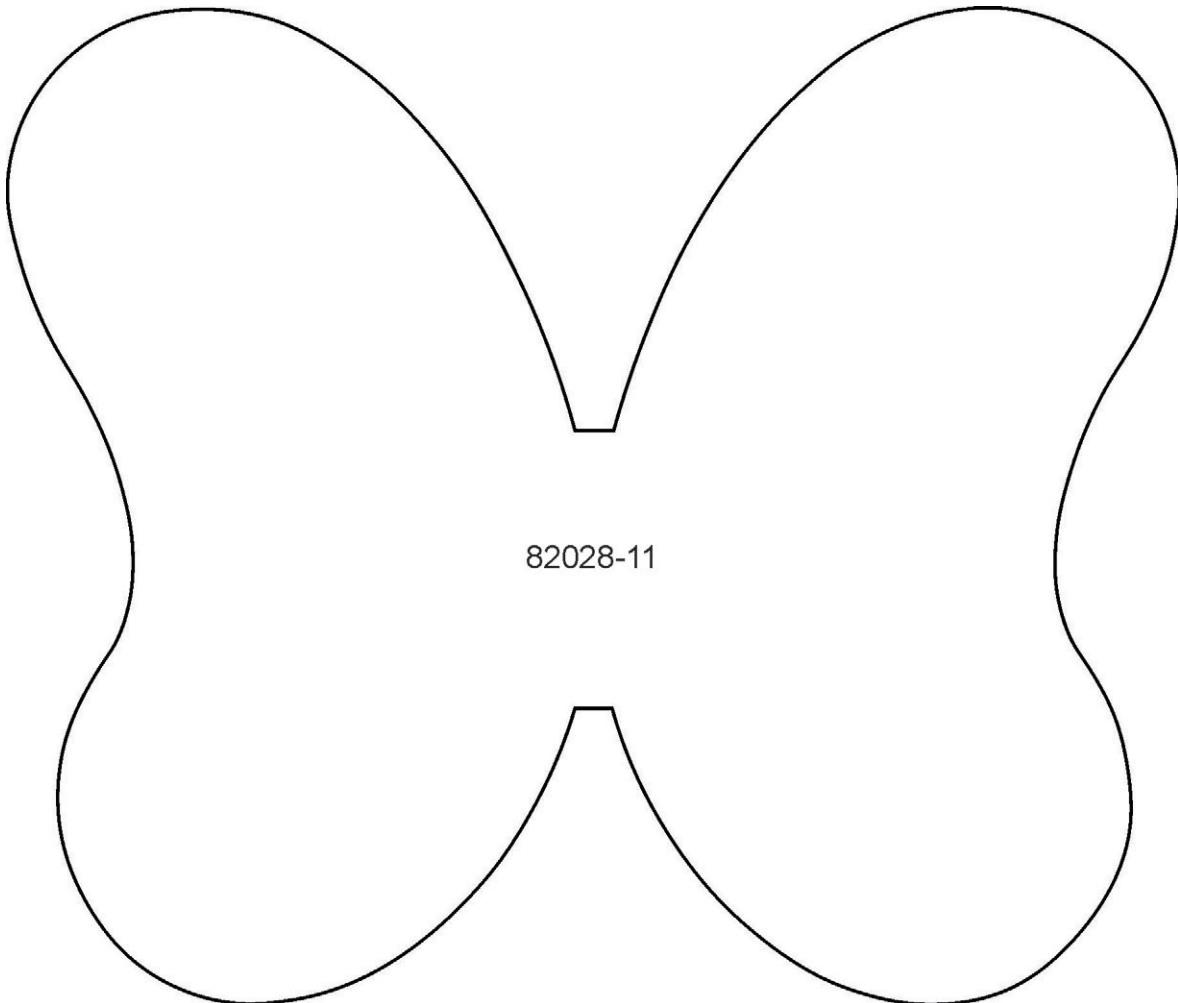

82028-11

